

Dimensioning and Tolerancing

Engineering Product Definition and Related Documentation Practices

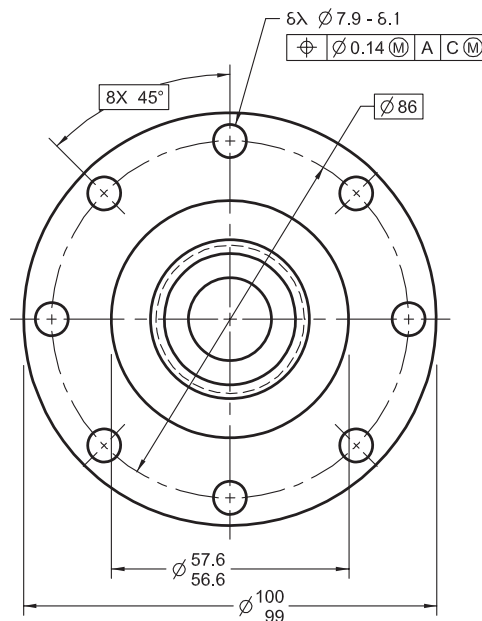

AN INTERNATIONAL STANDARD



**The American Society of
Mechanical Engineers**

ADOPTION NOTICE

ASME Y14.5, Dimensioning and Tolerancing, was adopted on 9 February 2009 for use by the Department of Defense (DoD). Proposed changes by DoD activities must be submitted to the DoD Adopting Activity: Commander, U.S. Army Research, Development and Engineering Center (ARDEC), ATTN: AMSRD-AAR-QES-E, Picatinny Arsenal, NJ 07806-5000. Copies of this document may be purchased from The American Society of Mechanical Engineers (ASME), 150 Clove Road, 6th Floor, Little Falls, NJ 07424-2139; <http://www.asme.org>.

Custodians:

Army — AR
Navy — SA
Air Force — 16

Adopting Activity:

Army — AR
(Project DRPR-2009-003)

Review Activities:

Army — CR, MI, PT, TM
Navy — AS, CG, CH, EC, MC, NP, TD
Air Force — 13, 99
DLA — DH
OSD — SE
NSA — NS
Other — CM, MP, DC2

NOTE: The activities listed above were interested in this document as of the date of this document. Since organizations and responsibilities can change, you should verify the currency of the information above using the ASSIST Online database at <https://quicksearch.dla.mil>.

ASMC N\A

AREA DRPR

DISTRIBUTION STATEMENT A. Approved for public release, distribution is unlimited.

ASME Y14.5-2018
(Revision of ASME Y14.5-2009)

Dimensioning and Tolerancing

**Engineering Product Definition and
Related Documentation Practices**

AN INTERNATIONAL STANDARD



**The American Society of
Mechanical Engineers**

Two Park Avenue • New York, NY • 10016 USA

Date of Issuance: February 11, 2019

This Standard will be revised when the Society approves the issuance of a new edition.

Periodically certain actions of the ASME Y14 Committee may be published as Cases. Cases are published on the ASME website under the Y14 Committee Page at <http://go.asme.org/Y14committee> as they are issued.

Errata to codes and standards may be posted on the ASME website under the Committee Pages to provide corrections to incorrectly published items, or to correct typographical or grammatical errors in codes and standards. Such errata shall be used on the date posted.

The Y14 Committee Page can be found at <http://go.asme.org/Y14committee>. There is an option available to automatically receive an e-mail notification when errata are posted to a particular code or standard. This option can be found on the appropriate Committee Page after selecting "Errata" in the "Publication Information" section.

ASME is the registered trademark of The American Society of Mechanical Engineers.

This international code or standard was developed under procedures accredited as meeting the criteria for American National Standards and it is an American National Standard. The Standards Committee that approved the code or standard was balanced to assure that individuals from competent and concerned interests have had an opportunity to participate. The proposed code or standard was made available for public review and comment that provides an opportunity for additional public input from industry, academia, regulatory agencies, and the public-at-large.

ASME does not "approve," "rate," or "endorse" any item, construction, proprietary device, or activity.

ASME does not take any position with respect to the validity of any patent rights asserted in connection with any items mentioned in this document, and does not undertake to insure anyone utilizing a standard against liability for infringement of any applicable letters patent, nor assume any such liability. Users of a code or standard are expressly advised that determination of the validity of any such patent rights, and the risk of infringement of such rights, is entirely their own responsibility.

Participation by federal agency representative(s) or person(s) affiliated with industry is not to be interpreted as government or industry endorsement of this code or standard.

ASME accepts responsibility for only those interpretations of this document issued in accordance with the established ASME procedures and policies, which precludes the issuance of interpretations by individuals.

No part of this document may be reproduced in any form,
in an electronic retrieval system or otherwise,
without the prior written permission of the publisher.

The American Society of Mechanical Engineers
Two Park Avenue, New York, NY 10016-5990

Copyright © 2019 by
THE AMERICAN SOCIETY OF MECHANICAL ENGINEERS
All rights reserved
Printed in U.S.A.

CONTENTS

Foreword	xiv	
Committee Roster	xv	
Correspondence With the Y14 Committee	xvi	
Section 1	Scope	1
1.1	Introduction	1
1.2	General	1
1.3	Reference to This Standard	1
1.4	ASME Y14 Series Conventions	1
1.5	Drawings Without Reference to a Standard	2
1.6	Reference to Gaging	2
1.7	Symbols	3
Section 2	References	4
2.1	Introduction	4
2.2	Cited Standards	4
2.3	Additional Sources (Not Cited)	4
Section 3	Definitions	5
Section 4	Fundamental Rules, Tolerancing Defaults, and Dimensioning Practices	12
4.1	Fundamental Rules	12
4.2	Units of Measure	13
4.3	Types of Dimensioning	13
4.4	Application of Dimensions	14
4.5	Dimensioning Features	15
4.6	Location of Features	18
Section 5	Tolerancing, Interpretation of Limits, Limits of Size, and Material Condition Modifiers	33
5.1	General	33
5.2	Direct Tolerancing Methods	33
5.3	Tolerance Expression	34
5.4	Interpretation of Limits	34
5.5	Single Limit Toleranced Dimensions	35
5.6	Tolerance Accumulation Between Surfaces	35
5.7	Dimensions Related to an Origin	35
5.8	Limits of Size	35
5.9	Applicability of Modifiers on Geometric Tolerance Values and Datum Feature References .	36
5.10	Screw Threads	38
5.11	Gears and Splines	38
5.12	Boundary Conditions	38
5.13	Angular Surfaces	38
5.14	Conical Tapers	38

5.15	Flat Tapers	39
5.16	Radius	39
5.17	Tangent Plane	39
5.18	Statistical Tolerancing	39
Section 6	Symbology	54
6.1	General	54
6.2	Use of Notes to Supplement Symbols	54
6.3	Symbol Construction	54
6.4	Feature Control Frame Symbols	57
6.5	Feature Control Frame Placement	58
6.6	Tolerance Zone Shape	58
6.7	Tabulated Tolerances	58
Section 7	Datum Reference Frames	70
7.1	General	70
7.2	Degrees of Freedom	70
7.3	Degrees of Freedom Constrained by Primary Datum Features RMB	70
7.4	Constraining Degrees of Freedom of a Part	70
7.5	True Geometric Counterpart	71
7.6	True Geometric Counterparts and Physical Datum Feature Simulators	71
7.7	Datum Reference Frame	71
7.8	Datum Features	72
7.9	Datum Feature Controls	72
7.10	Specifying Datum Features in an Order of Precedence	72
7.11	Establishing Datums	73
7.12	Common Datum Features	77
7.13	Mathematically Defined Surface	78
7.14	Multiple Datum Reference Frames	78
7.15	Functional Datum Features	78
7.16	Rotational Constraint About a Datum Axis or Point	78
7.17	Application of MMB, LMB, and RMB to Irregular Features of Size	80
7.18	Datum Feature Selection Practical Application	80
7.19	Simultaneous Requirements	80
7.20	Restrained Condition	81
7.21	Datum Reference Frame Identification	82
7.22	Customized Datum Reference Frame Construction	82
7.23	Application of a Customized Datum Reference Frame	82
7.24	Datum Targets	83
Section 8	Tolerances of Form	148
8.1	General	148
8.2	Form Control	148
8.3	Specifying Form Tolerances	148
8.4	Form Tolerances	148
8.5	Average Diameter	150
Section 9	Tolerances of Orientation	163
9.1	General	163

9.2	Orientation Control	163
9.3	Specifying Orientation Tolerances	163
9.4	Tangent Plane	164
9.5	Alternative Practice	164
Section 10	Tolerances of Position	179
10.1	General	179
10.2	Positional Tolerancing	179
10.3	Positional Tolerancing Fundamentals — I	179
10.4	Positional Tolerancing Fundamentals — II	182
10.5	Pattern Location	184
10.6	Coaxial Feature Controls	187
10.7	Tolerancing for Symmetrical Relationships	188
Section 11	Tolerances of Profile	240
11.1	General	240
11.2	Profile	240
11.3	Tolerance Zone Boundaries	240
11.4	Profile Applications	241
11.5	Material Condition and Boundary Condition Modifiers as Related to Profile Controls	242
11.6	Composite Profile	242
11.7	Multiple Single-Segment Profile Tolerancing	244
11.8	Combined Controls	244
11.9	Profile of a Line as a Refinement	244
11.10	Dynamic Profile Tolerance Modifier	244
Section 12	Tolerances of Runout	287
12.1	General	287
12.2	Runout	287
12.3	Runout Tolerance	287
12.4	Types of Runout Tolerances	287
12.5	Runout Tolerance and Size	288
12.6	Application	288
12.7	Specification	289
 Mandatory Appendix		
I	Alternate Practices	306
 Nonmandatory Appendices		
A	Principal Changes and Improvements	310
B	Formulas for Positional Tolerancing	315
C	Form, Proportion, and Comparison of Symbols	318
D	Former Practices	326
 Figures		
3-1	Related and Unrelated AME	10
3-2	Related and Unrelated Actual Minimum Material Envelope From Figure 3-1	11
4-1	Angular Units	19

4-2	Millimeter Dimensions	19
4-3	Decimal Inch Dimensions	19
4-4	Application of Dimensions	19
4-5	Grouping of Dimensions	19
4-6	Spacing of Dimension Lines	20
4-7	Staggered Dimensions	20
4-8	Oblique Extension Lines	20
4-9	Breaks in Extension Lines	20
4-10	Point Locations	20
4-11	Limited Length or Area Indication	21
4-12	Leaders	21
4-13	Leader-Directed Dimensions	21
4-14	Minimizing Leaders	22
4-15	Leader Directions	22
4-16	Reading Directions	22
4-17	Intermediate Reference Dimension	22
4-18	Overall Reference Dimension	22
4-19	Diameters	23
4-20	Radii	23
4-21	Radius With Located Center	23
4-22	Radii With Unlocated Centers	23
4-23	Foreshortened Radii	24
4-24	True Radius	24
4-25	Spherical Radius	24
4-26	Dimensioning Arcs and Chords	24
4-27	Slotted Holes	25
4-28	Partially Rounded Ends	25
4-29	Rounded Corners	25
4-30	Circular Arc Outline	25
4-31	Coordinate or Offset Outline	25
4-32	Tabulated Outline	25
4-33	Symmetrical Outline	26
4-34	Round Holes	26
4-35	Counterbored Holes	26
4-36	Holes With Multiple Counterbores	27
4-37	Countersunk and Counterdrilled Holes	27
4-38	Countersink on a Curved Surface	28
4-39	Spotfaced Holes	28
4-40	Chamfers	28
4-41	45° Chamfer	28
4-42	Internal Chamfers	29
4-43	Chamfers Between Surfaces at Other Than 90°	29
4-44	Keyseats	29
4-45	Knurls	29
4-46	Knurls for Press Fits	29

4-47	Rectangular Coordinate Dimensioning	30
4-48	Rectangular Coordinate Dimensioning Without Dimension Lines	30
4-49	Rectangular Coordinate Dimensioning in Tabular Form	31
4-50	Polar Coordinate Dimensioning	31
4-51	Repetitive Features	31
4-52	Repetitive Features and Dimensions	32
5-1	Limit Dimensioning	40
5-2	Plus and Minus Tolerancing	40
5-3	Indicating Symbols for Metric Limits and Fits	40
5-4	Tolerance Accumulation: One Datum Reference Frame	41
5-5	Tolerance Accumulation: Multiple Datum Reference Frames	42
5-6	Relating Dimensional Limits to an Origin	42
5-7	Extreme Variations of Form Allowed by a Size Tolerance	43
5-8	Extreme Variations of Form Allowed by a Geometric Tolerance — Perfect Form at LMC	43
5-9	Size Meaning	44
5-10	Independency and Flatness Application	44
5-11	Continuous Feature, External Cylindrical	45
5-12	Continuous Feature, Internal Cylindrical	45
5-13	Continuous Feature, External Width	46
5-14	Virtual and Resultant Condition Boundaries Using the MMC Concept — Internal Feature	46
5-15	Virtual and Resultant Condition Boundaries Using the LMC Concept — Internal Feature	47
5-16	Inner and Outer Boundaries Using the RFS Concept — Internal Feature	48
5-17	Virtual and Resultant Condition Boundaries Using the MMC Concept — External Feature	49
5-18	Virtual and Resultant Condition Boundaries Using the LMC Concept — External Feature	50
5-19	Inner and Outer Condition Boundaries Using the RFS Concept — External Feature	51
5-20	Tolerancing an Angular Surface Using a Combination of Linear and Angular Dimensions	51
5-21	Specifying Tapers	52
5-22	Specifying a Basic Taper and a Basic Diameter	52
5-23	Specifying a Flat Taper	52
5-24	Specifying a Radius	52
5-25	Specifying a Controlled Radius	53
5-26	Statistical Tolerancing	53
5-27	Statistical Tolerancing With Arithmetic Limits	53
5-28	Statistical Tolerancing With Geometric Controls	53
6-1	Geometric Characteristic Symbols	59
6-2	Datum Feature Symbol	59
6-3	Datum Feature Symbols on a Feature Surface and an Extension Line	59
6-4	Placement of Datum Feature Symbols on Features of Size	60
6-5	Placement of Datum Feature Symbol in Conjunction With a Feature Control Frame	60
6-6	Two Datum Features Establishing a Single Datum Plane	61
6-7	Datum Target Symbol Examples	61
6-8	Datum Target Point	61
6-9	Datum Target Line	62
6-10	Datum Target Area	62
6-11	Basic Dimension Symbol Application	63

6-12	Modifying Symbols	63
6-13	Indicating That the Specified Tolerance Is a Statistical Geometric Tolerance	63
6-14	Statistical Tolerance Symbol	63
6-15	“Between” Symbol	63
6-16	Counterbore and Spotface Symbols	64
6-17	Countersink Symbol	64
6-18	Depth Symbol	64
6-19	Square Symbol	65
6-20	Dimension Origin Symbol	65
6-21	Application of “All Over” and “All Around” Symbols	65
6-22	Feature Control Frame With “Free State” Symbol	65
6-23	Application of “Movable Datum Target” Symbol	65
6-24	Feature Control Frame	65
6-25	Feature Control Frame Incorporating a Datum Feature Reference	65
6-26	Order of Precedence of Datum Feature Reference	66
6-27	Multiple Feature Control Frames	66
6-28	Combined Feature Control Frame and Datum Feature Symbol	66
6-29	Feature Control Frame With a Projected Tolerance Zone Symbol	66
6-30	Feature Control Frame Placement	67
6-31	Tabulated Tolerances	69
7-1	Datum Reference Frame	85
7-2	Sequence of Datum Features Relates Part to Datum Reference Frame	86
7-3	Constrained Degrees of Freedom for Primary Datum Features	87
7-4	Part Where Rotational Constraint Is Important	88
7-5	Development of a Datum Reference Frame for the Part in Figure 7-4	89
7-6	Development of a Datum Reference Frame	90
7-7	Datum Plane Establishment	92
7-8	Establishment of Datums for Primary External Cylindrical Datum Feature RMB	92
7-9	Establishment of Datums for Primary Internal Cylindrical Datum Feature RMB	93
7-10	Establishment of Datums for Primary External Datum Width Feature RMB	94
7-11	Establishment of Datums for Primary Internal Datum Width Feature RMB	95
7-12	Development of a Datum Reference Frame With Translation Modifier	96
7-13	Inclined Datum Feature	98
7-14	Part With Cylindrical Datum Feature	99
7-15	Multiple Datum Reference Frames and Their Interrelationships	100
7-16	Two Coaxial Datum Features, Single Datum Axis	101
7-17	Two Datum Features RMB, Single Datum Axis	102
7-18	Hole Pattern Identified as Datum Feature	103
7-19	Effect of Secondary Datum Feature Reference Applicable at RMB and MMB	104
7-20	Effect of Primary Datum Feature Reference Applicable at RMB and MMB	105
7-21	Secondary and Tertiary Datum Features RMB	106
7-22	Example Calculations of MMB	107
7-23	Example Calculations of LMB	108
7-24	Example Calculations of Maximum External Boundary for RMB Applications	109
7-25	Secondary and Tertiary Datum Features at LMB	110

7-26	Secondary and Tertiary Datum Features at MMB	111
7-27	Planar Common Datum Features	112
7-28	Partial Surface as a Datum Feature	113
7-29	Contoured Surface as a Datum Feature	114
7-30	Contoured Datum Feature Constraining a Rotational Degree of Freedom: Secondary Datum Feature RMB	115
7-31	Contoured Datum Feature Constraining a Rotational Degree of Freedom: Secondary Datum Feature at MMB	115
7-32	Planar Datum Feature Constraining a Rotational Degree of Freedom: Secondary Datum Feature RMB	116
7-33	Planar Datum Feature Constraining a Rotational Degree of Freedom: Secondary Datum Feature at MMB	116
7-34	Planar Datum Feature Constraining a Rotational Degree of Freedom: Secondary Datum Feature RMB	117
7-35	Planar Datum Feature Constraining a Rotational Degree of Freedom: Secondary Datum Feature at BSC	117
7-36	Planar Datum Feature Constraining a Rotational Degree of Freedom: Secondary Datum Feature at MMB	118
7-37	Planar Datum Feature Constraining a Rotational Degree of Freedom: Secondary Datum Feature at LMB	118
7-38	Size Datum Feature Constraining a Rotational Degree of Freedom: Secondary Datum Feature RMB	119
7-39	Size Datum Feature Constraining a Rotational Degree of Freedom: Secondary Datum Feature RMB, Translate	119
7-40	Irregular and Regular Features of Size as Datum Features	120
7-41	Coaxial Irregular Datum Feature of Size	122
7-42	Possible Datum Feature and True Geometric Counterparts From Three Pins Used as an Irregular Feature of Size	124
7-43	Mating Parts for Functional Datum Section	125
7-44	Functional Datum Application: Pulley	126
7-45	Functional Datum Application: Adapter	127
7-46	Simultaneous Position and Profile Tolerances	128
7-47	Part With Nominally Aligned Features: Simultaneous Requirement	129
7-48	Part With Nominally Aligned Features: Separate Requirements	130
7-49	Restrained Condition Application	131
7-50	Indication of Unrestrained Datum Targets for a Primary Multiple Datum Feature Reference	132
7-51	Indication of Unrestrained Datum Targets for a Secondary Datum Feature Reference	133
7-52	Planar Combined Datum Features	134
7-53	Datum Targets Used to Establish Datum Reference Frame for Complex Part	135
7-54	Datum Reference Frame Identification	136
7-55	Conical Datum Feature Referenced to Constrain Five Degrees of Freedom	137
7-56	Conical Datum Feature Reference Customized to Constrain Four Degrees of Freedom	138
7-57	Customized Datum Reference Frame	139
7-58	Application of Movable Datum Targets	140
7-59	Datum Target Spheres	142
7-60	Application of Datum Targets to Establish a Datum Reference Frame	143
7-61	Primary Datum Axis Established by Datum Target Points on a Single Cylindrical Feature	144

7-62	Primary and Secondary Datums Established by Datum Target Lines on Two Cylindrical Features and a Surface	145
7-63	Datum Target Line and Area	146
7-64	Secondary Datum Axis	147
8-1	Specifying Straightness of a Flat Surface	151
8-2	Specifying Straightness of Surface Elements	152
8-3	Specifying Straightness RFS	153
8-4	Specifying Straightness at MMC	154
8-5	Specifying Straightness per Unit Length With Specified Total Straightness, Both RFS	155
8-6	Possible Results of Specifying Straightness per Unit Length RFS, With No Specified Total	156
8-7	Specifying Flatness of a Surface	156
8-8	Specifying Flatness of a Derived Median Plane RFS	157
8-9	Specifying Flatness of a Derived Median Plane at MMC	158
8-10	Specifying Circularity for a Cylinder or Cone	159
8-11	Specifying Circularity of a Sphere	160
8-12	Specifying Cylindricity	160
8-13	Specifying Circularity With Average Diameter	161
8-14	Specifying Restraint for Nonrigid Parts	162
9-1	Specifying Angularity for a Plane Surface	165
9-2	Specifying Parallelism for a Plane Surface	165
9-3	Specifying Perpendicularity for a Plane Surface	166
9-4	Specifying Orientation for a Plane Surface Relative to Two Datums	166
9-5	Specifying Perpendicularity for a Center Plane (Feature RFS)	167
9-6	Specifying Angularity for an Axis (Feature RFS)	167
9-7	Specifying Parallelism for an Axis (Feature RFS)	168
9-8	Specifying Angularity for an Axis With Two Datum Feature References (Feature RFS)	169
9-9	Specifying Parallelism for an Axis (Both Feature and Datum Feature RFS)	170
9-10	Specifying Parallelism for an Axis (Feature at MMC and Datum Feature RFS)	171
9-11	Specifying Perpendicularity for an Axis at a Projected Height (Threaded Hole or Insert at MMC)	172
9-12	Specifying Perpendicularity for an Axis (Pin or Boss RFS)	173
9-13	Specifying Perpendicularity for an Axis Showing Acceptance Boundary (Pin or Boss at MMC)	174
9-14	Specifying Perpendicularity for an Axis (Zero Tolerance at MMC)	175
9-15	Specifying Perpendicularity for an Axis (Zero Tolerance at MMC With a Maximum Specified)	176
9-16	Specifying Orientation for a Curved Surface Relative to a Planar Datum Feature	177
9-17	Specifying Parallelism With a Tangent Plane and Profile of a Surface	178
9-18	Specifying Parallelism With a Tangent Plane	178
10-1	Identifying Basic Dimensions	189
10-2	Positional Tolerancing With Datum References	190
10-3	Positional Tolerancing Relative to Planar Datum Feature Surfaces	191
10-4	Positional Tolerancing at MMC Relative to Datum Feature Center Planes	192
10-5	RFS Applicable to a Feature Tolerance and RMB Applied to a Datum Feature Reference	192
10-6	Possible Axis Interpretation Error	193
10-7	Boundary for Surface of a Hole at MMC	193
10-8	Surface Interpretation for Position Tolerance at MMC	194
10-9	Axis Interpretation for Position Tolerance at MMC	194

10-10	Increase in Positional Tolerance Where Hole Is Not at MMC	195
10-11	Positional Tolerancing at MMC	195
10-12	Zero Positional Tolerancing at MMC	196
10-13	Increase in Positional Tolerance Where Hole Is Not at LMC	196
10-14	LMC Applied to Boss and Hole	197
10-15	Zero Tolerance at LMC Applied to Boss and Hole	198
10-16	LMC Applied to a Single Feature	199
10-17	LMC Applied to Pattern of Slots	200
10-18	Datum Feature at LMB	200
10-19	Datum Feature Referenced at MMB	201
10-20	Interference Diagram, Fastener and Hole	202
10-21	Basis for Projected Tolerance Zone	202
10-22	Projected Tolerance Zone Specified	202
10-23	Projected Tolerance Zone Indicated With Chain Line	203
10-24	Projected Tolerance Zone Applied for Studs or Dowel Pins	203
10-25	Same Positional Tolerance for Holes and Counterbores, Same Datum References	203
10-26	Different Positional Tolerances for Holes and Counterbores, Same Datum References	204
10-27	Positional Tolerances for Holes and Counterbores, Different Datum References	204
10-28	Different Positional Tolerance at Each End of a Long Hole	205
10-29	Bidirectional Positional Tolerancing, Rectangular Coordinate Method	205
10-30	Bidirectional Positional Tolerancing, Polar Coordinate Method	206
10-31	Positional Tolerancing of Tabs	206
10-32	Positional Tolerancing of Slots	207
10-33	Virtual Condition for Surfaces of Slot at MMC	207
10-34	Tolerance Zone for Center Plane of Slot at MMC	207
10-35	Positional Tolerancing, Boundary Concept	208
10-36	Spherical Feature Located by Positional Tolerancing	210
10-37	Nonparallel Holes Including Those Not Normal to the Surface	211
10-38	Multiple Patterns of Features	212
10-39	Hole Patterns Located by Composite Positional Tolerancing	214
10-40	Hole Patterns of Figure 10-38 With Secondary Datums in Feature-Relating Segments of Composite Feature Control Frames	218
10-41	Composite Positional Tolerancing of a Circular Pattern of Features	219
10-42	Radial Hole Pattern Located by Composite Positional Tolerancing — Repeated Primary Datum Reference	220
10-43	Radial Hole Pattern Located by Composite Positional Tolerancing — Repeated All Datum References	222
10-44	Orientation Relative to Three Datum Planes	223
10-45	Positional Tolerancing for Coaxial Holes of Same Size, Partial (Parallelism) Refinement of Feature-Relating Axis Relative to Datums A and B With Further Refinement of Parallelism to Datum A	224
10-46	Three-Segment Composite Tolerance	226
10-47	Multiple Single-Segment Feature Control Frames With Secondary Datum in Lower Feature Control Frame	227
10-48	Positional Tolerancing With Multiple Single-Segment Feature Control Frames	229
10-49	Radial Hole Pattern Located by Multiple Single-Segment Feature Control Frames	230

10-50	Positional Tolerancing for Coaxial Holes of Same Size	231
10-51	Positional Tolerancing for Coaxial Holes of Same Size, Partial (Parallelism) Refinement of Feature of Feature-Relating Axis	232
10-52	Positional Tolerancing for Multiple Features of More Than One Size	232
10-53	Multiple Patterns of Features, Simultaneous Requirement	233
10-54	Multiple Patterns of Features, Separate Requirements	235
10-55	Multiple Positional Tolerancing for a Pattern of Features	236
10-56	Positional Tolerancing for Coaxiality	237
10-57	Feature Controlled With Positional Tolerance RFS and Datum Referenced RMB for Coaxiality	238
10-58	Two Datum Features, Single Datum Axis	238
10-59	Positional Tolerancing at MMC for Symmetrical Features	239
10-60	Positional Tolerancing RFS for Symmetrical Features	239
11-1	Profile of a Surface Application (Bilateral)	246
11-2	Profile of a Surface Application (Unilaterally Inside)	247
11-3	Profile of a Surface Application (Unilaterally Outside)	248
11-4	Profile of a Surface Application (Unequally Disposed)	249
11-5	Specifying the Profile of a Surface for Sharp Corners	250
11-6	Specifying Profile of a Surface All Around	251
11-7	Application of Profile of a Surface Tolerance to a Basic Contour	252
11-8	Specifying Different Profile Tolerances on Segments of a Profile	253
11-9	Specifying Profile of a Surface Between Points	254
11-10	Specifying Profile of a Surface All Over	255
11-11	Nonuniform Profile Tolerance Zone	255
11-12	Nonuniform Profile Tolerance Zone With Multiple Segments	256
11-13	Nonuniform Profile Tolerance Zone With Zones to Smooth Transitions	257
11-14	Nonuniform Profile Tolerance Zone Alternate Practice	258
11-15	Specifying the Profile of a Surface for a Plane Surface	259
11-16	Specifying the Profile of a Surface for Coplanar Surfaces	260
11-17	Specifying the Profile of a Surface for Coplanar Surfaces to a Datum Established by Two Surfaces	261
11-18	Specifying the Profile of a Surface for Stepped Surfaces	262
11-19	Specifying the Profile of a Conical Feature	262
11-20	Profile Tolerancing of a Conical Feature, Datum Related	263
11-21	The Toleranced Feature Is a Referenced Datum Feature	264
11-22	The Toleranced Feature Includes Referenced Datum Targets	265
11-23	“Continuous Feature” Symbol Application in a Profile Tolerance	266
11-24	Composite Profile Tolerancing of an Irregular Feature	267
11-25	Composite Profile Tolerancing of a Feature	268
11-26	Pattern Located by Composite Profile Tolerancing — Repeated Primary Datum Feature Reference	269
11-27	Pattern Located by Composite Profile Tolerancing — Repeated Primary and Secondary Datum Feature References	272
11-28	Irregular Shaped Feature With a Profile Size/Form Control and the Pattern Located by Composite Profile Tolerance	275
11-29	MMC Principle Used With Profile Controls	276
11-30	Profile of a Surface of Revolution	277
11-31	Specifying the Combined Profile of a Surface and a Line Tolerance	278

11-32	Profile of a Line and Size Control	280
11-33	Specifying Perpendicularity for a Radial Element of a Surface	281
11-34	Constrained Degree of Freedom Used With Profile of a Line	282
11-35	Composite Profile With Dynamic Profile to Control Form	283
11-36	Composite Profile With Dynamic Profile to Control Form and Constrain Rotational Degrees of Freedom	284
11-37	Use of Dynamic Profile in a Two-Single-Segment Profile Tolerance	285
11-38	Dynamic Profile of a Surface of Revolution	286
12-1	Features Applicable to Runout Tolerancing	290
12-2	Specifying Circular Runout — Small Size Tolerance and Large Runout Tolerance	291
12-3	Specifying Circular Runout Relative to a Datum Axis	292
12-4	Total Runout Applied on a Cylinder and Referenced to a Datum Axis	293
12-5	Total Runout Applied on a Face Surface and Referenced to a Datum Axis	294
12-6	Size and Runout Tolerance Effects	295
12-7	Specifying Circular Runout Using a Large Size Tolerance and a Small Runout Tolerance	296
12-8	Specifying Total Runout Using a Large Size Tolerance and a Small Runout Tolerance	297
12-9	Specifying Runout Relative to Two Cylindrical Datum Features	298
12-10	Specifying Runout to a Surface and Diameter	299
12-11	Specifying Runout Relative to Two Datum Diameters With Form Control Specified	300
12-12	Specifying Runout Relative to a Surface and Diameter With Form Control Specified	301
12-13	Total Runout Tolerance Applied to a Tangent Plane	302
12-14	Total Runout Tolerance Applied to a Tangent Plane With Alternate Method to Establish Datum Axis	303
12-15	Surface Profile Tolerance Applied to a Tangent Plane	304
12-16	Runout Tolerance Applied on an Assembly	305
I-1	Tolerance Accumulation	308
I-2	Tolerance Accumulation Ambiguity	309
A-1	Specifying Total Runout Relative to a Datum Diameter	314
B-1	Floating Fasteners	317
B-2	Fixed Fasteners	317
B-3	Coaxial Features	317
C-1	Form and Proportion of Datum Symbols	319
C-2	Form and Proportion of Geometric Characteristic Symbols	320
C-3	Form and Proportion of Geometric Dimensioning Symbols	321
C-4	Form and Proportion of Modifying Symbols	322
C-5	Form and Proportion of Dimensioning Symbols and Letters	323
C-6	Comparison of Symbols	324
C-7	Comparison of Other Symbols	325

FOREWORD

This issue is a revision of ASME Y14.5-2009, Dimensioning and Tolerancing. The objectives for this revision are to correct any inconsistencies in the previous edition, to determine actions based on deferred comments from the review of the previous edition's draft, to include model-based applications in many of the example figures, and to address proposals submitted by the public or members of the Subcommittee. Based on guidance from the Y14 Committee, the material formerly in Section 1 has been reorganized into [Sections 1](#) through [4](#), and the subsequent Sections have been renumbered.

Because of the widespread use of computer-aided design (CAD) and the industry transition toward reduced use of orthographic views for product definition, model views were added in many figures throughout the Standard. This is in part to ensure that this Standard is applicable to the use of dimensions and tolerances in models and model-based drawings. The methods of application in model views are currently defined in ASME Y14.41, but the meanings of the tolerances are defined in this Standard.

The Foreword of ASME Y14.5-2009 pointed out the increasing importance for design to more precisely state functional requirements through the use of geometric dimensioning and tolerancing (GD&T), and not to rely on the less definitive method of directly applied limit dimensions for form, orientation, location, and profile of part features. This 2018 revision emphasizes the use of profile for location tolerances applied to surfaces; the use of plus and minus tolerances has been moved to an Appendix that is likely to be removed in the next revision.

With a focus on making the transition from the previous edition to this edition simple, no reversals of tolerancing concepts have been made. However, two past practices, use of concentricity and use of symmetry symbols, are no longer supported. Both have been eliminated because other characteristics provide more direct control of features and establish requirements that have a well-defined meaning. Deletion of the symbols does not leave industry without a means to control coaxial or symmetrical features, but it does eliminate the confusion that surrounds these symbols and their misapplication.

Text and figure edits were made to improve readability and clarify content. Changes in sentence structure, organization of content, and method of illustration are not an indication of technical changes.

Work on this issue began at a meeting in Sarasota, Florida, in April 2009. Numerous deferred comments from the public review for the previous revision, as well as new proposals for revision and improvement from the Subcommittee and interested parties in the user community, were evaluated at subsequent semiannual meetings. The first draft entered the review process after it was completed in August 2015. Additional technical improvements and numerous editorial changes were made based on the comments received.

A Nonmandatory Appendix provides information about many of the updates in this edition of this Standard. One of the updates is an explicit statement that unless otherwise specified by drawing/model note or reference to a separate document, the as-designed dimension value does not establish a functional or manufacturing target. In addition, the term "true geometric counterpart" has replaced the term "theoretical datum feature simulator." The use of the "true geometric counterpart" term is limited to datums.

This Standard is available for public review on a continuing basis. This provides an opportunity for additional public-review input from industry, academia, regulatory agencies, and the public-at-large.

This revision was approved as an American National Standard on August 13, 2018.

ASME Y14 COMMITTEE

Engineering Product Definition and Related Documentation Practices

(The following is the roster of the Committee at the time of approval of this Standard.)

STANDARDS COMMITTEE OFFICERS

W. A. Kaba, Jr., *Chair*
J. I. Miles, *Vice Chair*
F. Constantino, *Secretary*

STANDARDS COMMITTEE PERSONNEL

A. R. Anderson , Dimensional Dynamics, LLC	A. Krulikowski , Krulikowski Consulting, LLC
F. Bakos , Consultant	E. McCarthy , E. F. McCarthy Consulting, Inc.
J. V. Burleigh , Unaffiliated	P. J. McCuistion , Multimac
F. Constantino , The American Society of Mechanical Engineers	J. D. Meadows , James D. Meadows & Associates, Inc.
D. O. Coon , Bell Helicopter	M. E. Meloro , Northrop Grumman Corp.
R. Courson , SAE International	J. I. Miles , Technical Consultants, Inc.
K. Dobert , Siemens PLM Software	M. A. Murphy , Unaffiliated
S. Hauger , Deere & Co.	H. W. Oakes , USAF University of Dayton Research Institute
J. B. Hoskins , Boeing Co.	B. A. Wilson , Consultant
J. Houck , Woodward, Inc.	E. F. Zwettler , Rolls-Royce Corp.
R. C. Jensen , Hexagon Manufacturing Intelligence	K. E. Wiegandt , <i>Contributing Member</i> , Consultant
W. A. Kaba, Jr. , Spirit AeroSystems, Inc.	

SUBCOMMITTEE 5 — DIMENSIONING AND TOLERANCING

B. A. Wilson , <i>Chair</i> , Consultant	P. Mares , Boeing Co.
A. G. Neumann , <i>Vice Chair</i> , Technical Consultants, Inc.	E. McCarthy , E. F. McCarthy Consulting, Inc.
M. E. Meloro , <i>Secretary</i> , Northrop Grumman Corp.	P. J. McCuistion , Multimac
A. R. Anderson , Dimensional Dynamics, LLC	M. A. Murphy , Unaffiliated
G. Arnold , GE Appliances/Haier	D. W. Shepherd , Shepherd Industries
F. Bakos , Consultant	P. C. Tillet , Naval Surface Warfare Center, Dahlgren Division
R. Courson , SAE International	D. Watts , Validate-3D, LLC
D. E. Day , Tec-Ease, Inc.	M. P. Wright , Lockheed Martin Aeronautics Co.
K. Dobert , Siemens PLM Software	E. F. Zwettler , Rolls-Royce Corp.
P. J. Drake, Jr. , MechSigma Consulting, Inc.	Jichang Yu , <i>Delegate</i> , Standardization Administration of China
B. R. Fischer , TDP 360, LLC	D. O. Coon , <i>Alternate</i> , Bell Helicopter
A. R. Gellings , Deere & Co.	J. Houck , <i>Alternate</i> , Woodward, Inc.
R. C. Hughes , El Camino College	N. W. Cutler , <i>Contributing Member</i> , Dimensional Management, Inc.
R. C. Jensen , Hexagon Manufacturing Intelligence	C. Houk , <i>Contributing Member</i> , Consultant
A. Krulikowski , Krulikowski Consulting, LLC	J. D. Keith , <i>Contributing Member</i> , Consultant

SUBCOMMITTEE 5 — SUPPORT GROUP

G. Fisher , Rolls-Royce Corp.	J. I. Miles , Technical Consultants, Inc.
M. Foster , Applied Geometrics, Inc.	S. Neumann , Technical Consultants, Inc.
J. D. Meadows , James D. Meadows & Associates, Inc.	J. Scheibel , Boeing Co.
P. Meadows , RCO Engineering, Inc.	R. A. Wheeler , RW-OptDesign, LLC

CORRESPONDENCE WITH THE Y14 COMMITTEE

General. ASME Standards are developed and maintained with the intent to represent the consensus of concerned interests. As such, users of this Standard may interact with the Committee by requesting interpretations, proposing revisions or a case, and attending Committee meetings. Correspondence should be addressed to:

Secretary, Y14 Standards Committee
The American Society of Mechanical Engineers
Two Park Avenue
New York, NY 10016-5990
<http://go.asme.org/Inquiry>

Proposing Revisions. Revisions are made periodically to the Standard to incorporate changes that appear necessary or desirable, as demonstrated by the experience gained from the application of the Standard. Approved revisions will be published periodically.

The Committee welcomes proposals for revisions to this Standard. Such proposals should be as specific as possible, citing the paragraph number(s), the proposed wording, and a detailed description of the reasons for the proposal, including any pertinent documentation.

Proposing a Case. Cases may be issued to provide alternative rules when justified, to permit early implementation of an approved revision when the need is urgent, or to provide rules not covered by existing provisions. Cases are effective immediately upon ASME approval and shall be posted on the ASME Committee web page.

Requests for Cases shall provide a Statement of Need and Background Information. The request should identify the Standard and the paragraph, figure, or table number(s), and be written as a Question and Reply in the same format as existing Cases. Requests for Cases should also indicate the applicable edition(s) of the Standard to which the proposed Case applies.

Attending Committee Meetings. The Y14 Standards Committee regularly holds meetings and/or telephone conferences that are open to the public. Persons wishing to attend any meeting and/or telephone conference should contact the Secretary of the Y14 Standards Committee. Future Committee meeting dates and locations can be found on the Committee Page at <http://go.asme.org/Y14committee>.

Section 1

Scope

1.1 INTRODUCTION

This Standard establishes symbols, rules, definitions, requirements, defaults, and recommended practices for stating and interpreting dimensioning, tolerancing, and related requirements for use on engineering drawings, models defined in digital data files, and related documents. For a mathematical explanation of many of the principles in this Standard, see ASME Y14.5.1M. Additional uniform practices for applying dimensions, tolerances, and related requirements in digital data sets are defined in ASME Y14.41. Practices unique to architectural and civil engineering and welding symbology are not included in this Standard.

1.2 GENERAL

Sections 1 through 4 establish related references, definitions, fundamental rules, and practices for general dimensioning. For tolerancing practices, see Sections 5 through 12. Additional information about tolerancing is in [Mandatory Appendix I](#) and [Nonmandatory Appendices A](#) through [D](#).

1.3 REFERENCE TO THIS STANDARD

When engineering documentation is based on this Standard, this fact shall be noted on the documentation or in a referenced separate document. References to this Standard shall include the designation of ASME Y14.5-2018.

1.4 ASME Y14 SERIES CONVENTIONS

The conventions in [paras. 1.4.1](#) through [1.4.10](#) are used in this and other ASME Y14 standards.

1.4.1 Mandatory, Recommended, Guidance, and Optional Words

- (a) The word “shall” establishes a requirement.
- (b) The word “will” establishes a declaration of purpose on the part of the design activity.
- (c) The word “should” establishes a recommended practice.
- (d) The word “may” establishes an allowed practice.

(e) The words “typical,” “example,” “for reference,” and the Latin abbreviation “e.g.” indicate suggestions given for guidance only.

(f) The word “or” used in conjunction with a requirement or a recommended practice indicates that there are two or more options for complying with the stated requirement or practice.

(g) The phrase “unless otherwise specified” (UOS) shall be used to indicate a default requirement. The phrase is used when the default is a generally applied requirement and an exception may be provided by another document or requirement.

1.4.2 Cross-Reference of Standards

Cross-reference of standards in text with or without a date following the standard designator shall be interpreted as follows:

(a) Reference to other ASME Y14 standards in the text without a date following the standard designator indicates that the issue of the standard identified in the References section ([Section 2](#)) shall be used to meet the requirement.

(b) Reference to other ASME Y14 standards in the text with a date following the standard designator indicates that only that issue of the standard shall be used to meet the requirement.

1.4.3 Invocation of Referenced Standards

The following examples define the invocation of a standard when specified in the References section ([Section 2](#)) and referenced in the text of this Standard:

(a) When a referenced standard is cited in the text with no limitations to a specific subject or paragraph(s) of the standard, the entire standard is invoked. For example, “Dimensioning and tolerancing shall be in accordance with ASME Y14.5” is invoking the complete standard because the subject of the standard is dimensioning and tolerancing and no specific subject or paragraph(s) within the standard are invoked.

(b) When a referenced standard is cited in the text with limitations to a specific subject or paragraph(s) of the standard, only the paragraph(s) on that subject are invoked. For example, “Assign part or identifying numbers in accordance with ASME Y14.100” is only invoking the paragraph(s) on part or identifying numbers because the subject of the standard is

engineering drawing practices and part or identifying numbers is a specific subject within the standard.

(c) When a referenced standard is cited in the text without an invoking statement such as “in accordance with,” the standard is for guidance only. For example, “For gaging principles, see ASME Y14.43” is only for guidance and no portion of the standard is invoked.

1.4.4 Parentheses Following a Definition

When a definition is followed by a standard referenced in parentheses, the standard referenced in parentheses is the source for the definition.

1.4.5 Notes

Notes depicted in this Standard in **ALL UPPERCASE** letters are intended to reflect actual drawing or model entries. Notes depicted in initial uppercase or lowercase letters are to be considered supporting data to the contents of this Standard and are not intended for literal entry on drawings. A statement requiring the addition of a note with the qualifier “such as” is a requirement to add a note, and the content of the text is allowed to vary to suit the application.

1.4.6 Acronyms and Abbreviations

Acronyms and abbreviations are spelled out the first time used in this Standard, followed by the acronym or abbreviation in parentheses. The acronym is used thereafter throughout the text.

1.4.7 Units

The International System of Units (SI) is featured in this Standard. It should be understood that U.S. Customary units could equally have been used without prejudice to the principles established. UOS, the unit for all dimension values in this Standard is the millimeter.

1.4.8 Figures

The figures in this Standard are intended only as illustrations to aid the user in understanding the practices described in the text. In some cases, figures show a level of detail as needed for emphasis. In other cases, figures are incomplete by intent so as to illustrate a concept or facet thereof. The absence of figure(s) has no bearing on the applicability of the stated requirements or practice. To comply with the requirements of this Standard, actual data sets shall meet the content requirements set forth in the text. To assist the user of this Standard, a list of the paragraph(s) that refer to an illustration appears in the lower right-hand corner of each figure. This list may not be all-inclusive. The absence of a paragraph reference is not a reason to assume inapplicability. Some figures are illustrations of models in a three-dimensional environment. The absence of dimen-

sioning and tolerancing annotations in a view may indicate that the product definition is defined in three dimensions. Dimensions that locate or orient and are not shown are considered basic and shall be queried to determine the intended requirement. When the letter “h” is used in figures for letter heights or for symbol proportions, select the applicable letter height in accordance with ASME Y14.2. Multiview drawings contained within figures are third angle projection.

1.4.9 Precedence of Standards

The following are ASME Y14 Standards that are basic engineering drawing standards:

ASME Y14.1, Decimal Inch Drawing Sheet Size and Format
 ASME Y14.1M, Metric Drawing Sheet Size and Format
 ASME Y14.2, Line Conventions and Lettering
 ASME Y14.3, Orthographic and Pictorial Views
 ASME Y14.5, Dimensioning and Tolerancing
 ASME Y14.24, Types and Applications of Engineering Drawings
 ASME Y14.34, Associated Lists
 ASME Y14.35, Revision of Engineering Drawings and Associated Documents
 ASME Y14.36, Surface Texture Symbols
 ASME Y14.38, Abbreviations and Acronyms for Use on Drawings and Related Documents
 ASME Y14.41, Digital Product Definition Data Practices
 ASME Y14.100, Engineering Drawing Practices

All other ASME Y14 standards are considered specialty types of standards and contain additional requirements or make exceptions to the basic standards as required to support a process or type of drawing.

1.4.10 Use of an ASME Y14 Case

Where engineering documentation is based on an ASME Y14 Case, this fact shall be noted on the documentation or in a referenced separate document.

1.5 DRAWINGS WITHOUT REFERENCE TO A STANDARD

When a drawing is produced without a reference to a standard (company, regional, national, or international) or contractually imposed documents, the drawing shall be interpreted in accordance with ASME PDS-1.1–2013.

1.6 REFERENCE TO GAGING

This document is not intended as a gaging standard. Any reference to gaging is included for explanatory purposes only. For gaging principles, see ASME Y14.43, Dimensioning and Tolerancing Principles for Gages and Fixtures.

1.7 SYMBOLS

Adoption of symbols indicating dimensional requirements, as shown in [Nonmandatory Appendix C](#), does not preclude the use of equivalent terms or abbreviations where symbology is considered inappropriate.

Section 2

References

2.1 INTRODUCTION

The following revisions of American National Standards form a part of this Standard to the extent specified herein. A more recent revision may be used provided there is no conflict with the text of this Standard. In the event of a conflict between the text of this Standard and the references cited herein, the text of this Standard shall take precedence.

2.2 CITED STANDARDS

ANSI B4.2-1978 (R2009), Preferred Metric Limits and Fits
 ANSI B89.3.1-1972 (R2003), Measurement of Out-of-Roundness
 ASME B1.1-2003 (R2008), Unified Inch Screw Threads (UN and UNR Thread Form)
 ASME B1.13M-2005 (R2015), Metric Screw Threads: M Profile
 ASME B5.10-1994 (R2013), Machine Tapers — Self Holding and Steep Taper Series
 ASME B46.1-2009, Surface Texture, Surface Roughness, Waviness, and Lay
 ASME B89.6.2-1973 (R2017), Temperature and Humidity Environment for Dimensional Measurement
 ASME B94.6-1984 (R2014), Knurling
 ASME B94.11M-1993, Twist Drills
 ASME PDS-1.1-2013, Dimensioning, Tolerancing, Surface Texture, and Metrology Standards — Rules for Drawings With Incomplete Reference to Applicable Drawing Standard
 ASME Y14.1-2012, Decimal Inch Drawing Sheet Size and Format
 ASME Y14.1M-2012, Metric Drawing Sheet Size and Format
 ASME Y14.2-2014, Line Conventions and Lettering

ASME Y14.5.1M-1994 (R2012), Mathematical Definition of Dimensioning and Tolerancing Principles
 ASME Y14.6-2001 (R2013), Screw Thread Representation
 ASME Y14.8-2009 (R2014), Castings, Forgings, and Molded Parts
 ASME Y14.36-2018, Surface Texture Symbols
 ASME Y14.41-2012, Digital Product Definition Data Practices
 ASME Y14.43-2011, Dimensioning and Tolerancing Principles for Gages and Fixtures
 USAS B4.1-1967 (R2004), Preferred Limits and Fits for Cylindrical Parts
 Publisher: The American Society of Mechanical Engineers (ASME), Two Park Avenue, New York, NY 10016-5990 (www.asme.org)

IEEE/ASTM SI 10-2016, American National Standard for Use of the International System of Units (SI): The Modern Metric System¹
 Publisher: Institute of Electrical and Electronics Engineers, Inc. (IEEE), 445 Hoes Lane, Piscataway, NJ 08854 (www.ieee.org)

2.3 ADDITIONAL SOURCES (NOT CITED)

ASME B1.2-1983 (R2017), Gages and Gaging for Unified Inch Screw Threads; Errata May 1992
 ASME B89.1.5-1998 (R2014), Measurement of Plain External Diameters for Use as Master Discs
 ASME Y14.3M-2012, Orthographic and Pictorial Views
 ASME Y14.38-2007 (R2013), Abbreviations and Acronyms for Use on Drawings and Related Documents
 ASME Y14.100-2017, Engineering Drawing Practices
 Publisher: The American Society of Mechanical Engineers (ASME), Two Park Avenue, New York, NY 10016-5990 (www.asme.org)

¹ IEEE/ASTM standards are also available from the American Society for Testing and Materials (ASTM International), 100 Barr Harbor Drive, P.O. Box C700, West Conshohocken, PA 19428-2959 (www.astm.org).

Section 3 Definitions

3.1 ANGULARITY

angularity: the condition of a line element, surface, feature's center plane, tangent plane, or feature's axis at an implied or specified basic angle of any value from one or more datum planes or datum axes.

3.2 BOUNDARY, INNER (IB)

boundary, inner: a worst-case boundary generated by the collective effects of the smallest feature of size (MMC for an internal feature of size, LMC for an external feature of size) and the applicable geometric tolerance. See [Figures 5-14](#) through [5-19](#).

3.3 BOUNDARY, LEAST MATERIAL (LMB)

boundary, least material: the worst-case boundary that exists on or inside the material of a feature(s) and is defined by the combined effects of size and geometric tolerances.

3.4 BOUNDARY, MAXIMUM MATERIAL (MMB)

boundary, maximum material: the worst-case boundary that exists on or outside the material of a feature(s) and is defined by the combined effects of size and geometric tolerances.

3.5 BOUNDARY, OUTER (OB)

boundary, outer: a worst-case boundary generated by the collective effects of the largest feature of size (LMC for an internal feature of size, MMC for an external feature of size) and the applicable geometric tolerance. See [Figures 5-10](#) and [5-14](#) through [5-19](#).

3.6 CIRCULARITY (ROUNDNESS)

circularity (roundness): the condition of a surface in which

- (a) for a feature other than a sphere, all points of each circumferential line created by the surface intersected by any plane perpendicular to the axis or spine (curved line) are equidistant from that axis or spine.
- (b) for a sphere, all points of the surface intersected by any plane passing through a common center are equidistant from that center.

3.7 COAXIALITY

coaxiality: the condition in which the axis of the unrelated actual mating envelope (AME) or axis of the unrelated minimum material envelope, as applicable, of one or more surfaces of revolution is coincident with a datum axis or another feature axis.

3.8 COMPLEX FEATURE

complex feature: a single surface of compound curvature or a collection of features.

3.9 CONSTRAINT

constraint: a limit to one or more degrees of freedom.

3.10 CONTINUOUS FEATURE

continuous feature: two or more interrupted features designated with a "CF" symbol, indicating they are to be considered as a single feature. See [Figure 11-23](#).

3.11 CONTINUOUS FEATURE OF SIZE

continuous feature of size: two or more regular features of size or an interrupted regular feature of size that is designated with a "CF" symbol, indicating they are to be considered as a single regular feature of size. See [Figure 5-11](#).

3.12 COPLANARITY

coplanarity: the condition of two or more surfaces having all elements in one plane.

3.13 CYLINDRICITY

cylindricity: the condition of a surface of revolution in which all points of the surface are equidistant from a common axis.

3.14 DATUM

datum: a theoretically exact point, axis, line, plane, or combination thereof derived from the true geometric counterpart.

3.15 DATUM AXIS

datum axis: the axis of a true geometric counterpart.

3.16 DATUM CENTER PLANE

datum center plane: the center plane of a true geometric counterpart.

3.17 DATUM FEATURE

datum feature: a feature that is identified with either a datum feature symbol or a datum target symbol(s).

3.18 DATUM FEATURE SIMULATOR

datum feature simulator: the physical boundary used to establish a simulated datum from a specified datum feature.

NOTE: For example, a gage, a fixture element, and digital data (such as machine tables, surface plates, a mandrel, or a mathematical simulation) are not true planes, but are of sufficient quality that the planes derived from them are used to establish simulated datums. Datum feature simulators are used as the physical embodiment of the true geometric counterparts during manufacturing and inspection. See ASME Y14.43.

3.19 DATUM REFERENCE FRAME

datum reference frame: three mutually perpendicular datum planes and three mutually perpendicular axes at the intersections of those planes. See [Figure 7-1](#).

3.20 DATUM, SIMULATED

datum, simulated: a point, axis, line, or plane (or combination thereof) derived from a datum feature simulator. See [subsection 7.6](#) and [Figure 7-7](#).

3.21 DATUM TARGET

datum target: the designated points, lines, or areas that are used in establishing a datum.

3.22 DERIVED MEDIAN LINE

derived median line: an imperfect (abstract) line formed by the center points of all cross sections of the feature. These cross sections are normal (perpendicular) to the axis of the unrelated AME. See [Figure 3-1](#).

3.23 DERIVED MEDIAN PLANE

derived median plane: an imperfect (abstract) plane formed by the center points of all line segments bounded by the feature. These line segments are normal (perpendicular) to the center plane of the unrelated AME.

3.24 DIAMETER, AVERAGE

diameter, average: the average of several diametric measurements across a circular or cylindrical feature.

3.25 DIMENSION

dimension: a numerical value(s) or mathematical expression in appropriate units of measure used to define the shape, size, orientation, or location of a part feature or between part features.

3.26 DIMENSION, BASIC

dimension, basic: a theoretically exact dimension.

NOTE: A basic dimension is indicated by one of the methods shown in [Figures 6-11](#) and [10-1](#).

3.27 DIMENSION, DIRECTLY TOLERANCED

dimension, directly toleranced: a dimension with an associated plus/minus tolerance or limit dimension values.

NOTE: Where a plus/minus general tolerance is applied to a dimension, the dimension is considered a directly toleranced dimension.

3.28 DIMENSION, REFERENCE

dimension, reference: dimensional information, usually without a tolerance, that is used for reference purposes only. A reference dimension is a repeat of a dimension or is derived from other values shown on the drawing or on related drawings. It is considered auxiliary information and does not govern production or inspection operations. See [Figures 4-17](#) and [4-18](#). Where a basic dimension is repeated on a drawing, it is not identified as reference. For information on how to indicate a reference dimension, see [para. 4.4.6](#).

3.29 ENVELOPE, ACTUAL MATING (AME)

envelope, actual mating: a similar perfect feature(s) counterpart of smallest size that can be contracted about an external feature(s) or of largest size that can be expanded within an internal feature(s) so that it coincides with the surface(s) at the highest points. This envelope is on or outside the material. There are two types of AMEs, as described below.

(a) *related AME:* a similar perfect feature(s) counterpart expanded within an internal feature(s) or contracted about an external feature(s) while constrained in orientation, in location, or in both orientation and location to the applicable datum(s). See [Figure 3-1](#).

(b) *unrelated AME:* a similar perfect feature(s) counterpart expanded within an internal feature(s) or contracted about an external feature(s), and not constrained to any datum(s). See [Figure 3-1](#).

3.30 ENVELOPE, ACTUAL MINIMUM MATERIAL

envelope, actual minimum material: a similar perfect feature(s) counterpart of largest size that can be expanded within an external feature(s) or of smallest size that can be

contracted about an internal feature(s) so that it coincides with the surface(s) at the lowest points. This envelope is on or within the material. There are two types of actual minimum material envelopes, as described below.

(a) *related actual minimum material envelope*: a similar perfect feature(s) counterpart contracted about an internal feature(s) or expanded within an external feature(s) while constrained in orientation, in location, or in both orientation and location to the applicable datum(s). See [Figure 3-2](#).

(b) *unrelated actual minimum material envelope*: a similar perfect feature(s) counterpart contracted about an internal feature(s) or expanded within an external feature(s), and not constrained to any datum reference frame. See [Figure 3-2](#).

3.31 FEATURE

feature: a physical portion of a part (such as a surface, pin outside diameter, hole, or slot) or its representation on drawings, models, or digital data files.

3.32 FEATURE AXIS

feature axis: the axis of the unrelated AME of a feature.

3.33 FEATURE, CENTER PLANE OF

feature, center plane of: the center plane of the unrelated AME of a feature.

3.34 FEATURE CONTROL FRAME

feature control frame: a rectangle divided into compartments containing the geometric characteristic symbol followed by the tolerance value or description, modifiers, and any applicable datum feature references. See [Figures 6-24](#) through [6-29](#).

3.35 FEATURE OF SIZE

feature of size: a general term that is used in this Standard to refer to instances in which both a regular and an irregular feature of size apply.

3.35.1 Irregular Feature of Size

irregular feature of size: there are two types of irregular features of size, as follows:

(a) a directly toleranced feature or collection of features that may contain or be contained by an unrelated AME that is a sphere, cylinder, or pair of parallel planes. See [Figure 7-41](#).

(b) a directly toleranced feature or collection of features that may contain or be contained by an unrelated AME other than a sphere, cylinder, or pair of parallel planes. See [Figures 7-40](#) and [11-29](#).

3.35.2 Regular Feature of Size

regular feature of size: one cylindrical surface, a spherical surface, a circular element, or a set of two opposed parallel line elements or opposed parallel surfaces associated with a single directly toleranced dimension. See [subsection 5.2](#) and [para. 5.8.1\(e\)](#).

3.36 FEATURE-RELATING TOLERANCE ZONE FRAMEWORK (FRTZF)

feature-relating tolerance zone framework: the tolerance zone framework that controls the basic relationship between the features in a pattern with that framework constrained in rotational degrees of freedom relative to any referenced datum features.

3.37 FLATNESS

flatness: the condition of a surface or derived median plane having all elements in one plane.

3.38 FREE STATE

free state: the condition in which no externally introduced forces other than gravity are applied to a part.

3.39 INTERRUPTION

interruption: a gap or gaps in a feature that divide it into two or more features (e.g., a slot or a groove).

3.40 LEAST MATERIAL CONDITION (LMC)

least material condition: the condition in which a feature of size contains the least amount of material within the stated limits of size, e.g., maximum hole diameter or minimum shaft diameter.

3.41 MAXIMUM MATERIAL CONDITION (MMC)

maximum material condition: the condition in which a feature of size contains the maximum amount of material within the stated limits of size, e.g., minimum hole diameter or maximum shaft diameter.

3.42 NONUNIFORM TOLERANCE ZONE

nonuniform tolerance zone: an MMB and an LMB, where at least one boundary is a specified shape that is not a uniform offset from true profile.

3.43 PARALLELISM

parallelism: the condition of a line element, surface, tangent plane, feature's center plane, or feature's axis at an implied or specified basic 0° (parallel) angle relative to one or more datum planes or datum axes.

3.44 PATTERN

pattern: two or more features to which a position or profile geometric tolerance is applied and that are grouped by one of the following methods: nX , n COAXIAL HOLES, ALL AROUND, ALL OVER, between A and B ($A \leftrightarrow B$), from A to B ($A \rightarrow B$), n SURFACES, simultaneous requirements, or INDICATED, where n in these examples represents a number.

3.45 PATTERN-LOCATING TOLERANCE ZONE FRAMEWORK (PLTZF)

pattern-locating tolerance zone framework: the tolerance zone framework that controls the basic relationship between the features in a pattern with that framework constrained in translational and rotational degrees of freedom relative to the referenced datum features.

3.46 PERPENDICULARITY

perpendicularity: the condition of a line element, surface, tangent plane, feature's center plane, or feature's axis at an implied or specified basic 90° (perpendicular) angle relative to one or more datum planes or datum axes.

3.47 PLANE, TANGENT

plane, tangent: a plane that contacts the high point or points of the specified surface.

3.48 POSITION

position: the location of one or more features of size relative to one another or to one or more datums.

3.49 PROFILE

profile: an outline of a surface, a shape made up of one or more features, or a two-dimensional element of one or more features.

3.50 REGARDLESS OF FEATURE SIZE (RFS)

regardless of feature size: a condition in which a geometric tolerance applies at any increment of size of the unrelated AME of the feature of size.

3.51 REGARDLESS OF MATERIAL BOUNDARY (RMB)

regardless of material boundary: a condition in which a movable or variable true geometric counterpart progresses from MMB toward LMB until it makes maximum allowable contact with the extremities of a datum feature(s) to establish a datum.

3.52 REPRESENTED LINE ELEMENT

represented line element: a supplemental geometry line or curve segment indicating the orientation of a direction-dependent tolerance. (ASME Y14.41)

3.53 RESTRAINED

restrained: the condition in which externally induced forces in addition to gravity are applied to a part.

3.54 RESULTANT CONDITION

resultant condition: the single worst-case boundary generated by the collective effects of a feature of size's specified MMC or LMC, the geometric tolerance for that material condition, the size tolerance, and the additional geometric tolerance derived from the feature's departure from its specified material condition. See [Figures 5-14, 5-15, 5-17, and 5-18](#).

3.55 RUNOUT

runout: a general term that applies to both circular and total runout.

3.55.1 Circular Runout

circular runout: the condition in which each circular element of a surface is at zero variation relative to a datum axis or axis of rotation established from the datum reference frame.

3.55.2 Total Runout

total runout: the condition in which all elements of a surface or tangent plane are at zero variation relative to a datum axis or axis of rotation established from the datum reference frame.

3.56 SIMULTANEOUS REQUIREMENT

simultaneous requirement: the condition in which two or more geometric tolerances apply as a single pattern or part requirement. See [subsection 7.19](#).

3.57 SIZE, ACTUAL LOCAL

size, actual local: the actual value of any individual distance at any cross section of a feature of size. See [Figure 3-1](#).

3.58 SIZE, LIMITS OF

size, limits of: the specified maximum and minimum sizes. See [subsection 5.5](#).

3.59 SIZE, NOMINAL

size, nominal: the designation used for purposes of general identification. (USAS B4.1)

3.60 STATISTICAL TOLERANCING

statistical tolerancing: the assigning of tolerances to related components of an assembly on the basis of sound statistics (e.g., the assembly tolerance is equal to the square root of the sum of the squares of the individual tolerances).

3.61 STRAIGHTNESS

straightness: the condition in which an element of a surface, or a derived median line, is a straight line.

3.62 TOLERANCE

tolerance: the total amount a dimension or feature is permitted to vary. The tolerance is the difference between the maximum and minimum limits.

3.63 TOLERANCE, BILATERAL

tolerance, bilateral: a tolerance in which variation is permitted in both directions from the specified dimension or true profile.

3.63.1 Tolerance, Equal Bilateral

tolerance, equal bilateral: a tolerance in which variation is permitted equally in both directions from the specified dimension or true profile.

3.63.2 Tolerance, Unequal Bilateral

tolerance, unequal bilateral: a tolerance that permits unequal amounts of variation in both directions from the specified dimension or true profile.

3.64 TOLERANCE, GEOMETRIC

tolerance, geometric: a tolerance indicated using a geometric characteristic symbol. See [Figure 6-1](#) for a list of the geometric characteristic symbols.

3.65 TOLERANCE, UNILATERAL

tolerance, unilateral: a tolerance in which variation is permitted in one direction from the specified dimension or true profile.

3.66 TRUE GEOMETRIC COUNTERPART

true geometric counterpart: the theoretically perfect boundary used to establish a datum from a specified datum feature.

NOTE: This term is only applicable to datums.

3.67 TRUE POSITION

true position: the theoretically exact location of a feature of size, as established by basic dimensions.

3.68 TRUE PROFILE

true profile: the profile defined by basic radii, basic angular dimensions, basic coordinate dimensions, basic dimension of size, undimensioned drawings, formulas, or mathematical data, including design models.

3.69 UNIFORM TOLERANCE ZONE

uniform tolerance zone: a constant distance between two boundaries equally or unequally disposed about the true profile or entirely disposed on one side of the true profile.

3.70 VIRTUAL CONDITION (VC)

virtual condition: a constant boundary generated by the collective effects of a considered feature of size's specified MMC or LMC and the geometric tolerance for that material condition. See [Figures 5-14](#), [5-15](#), [5-17](#), and [5-18](#).

Figure 3-1 Related and Unrelated AME

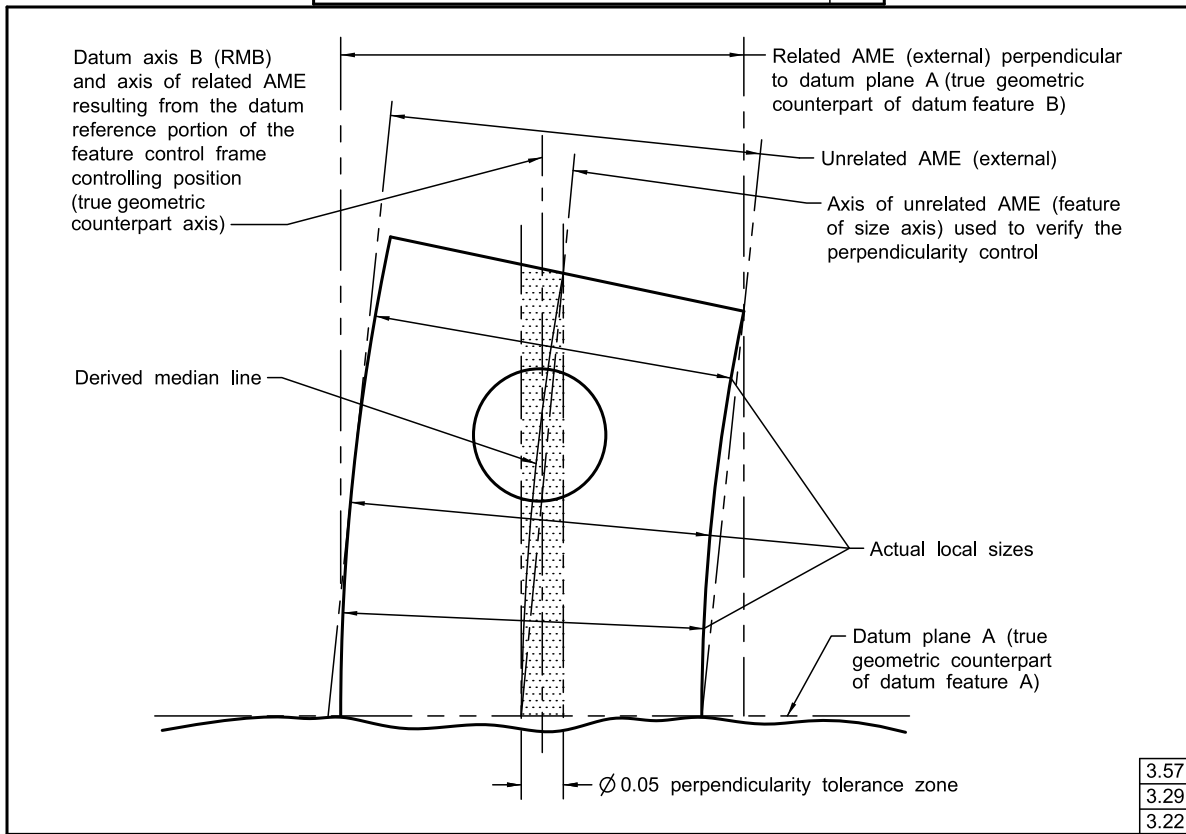
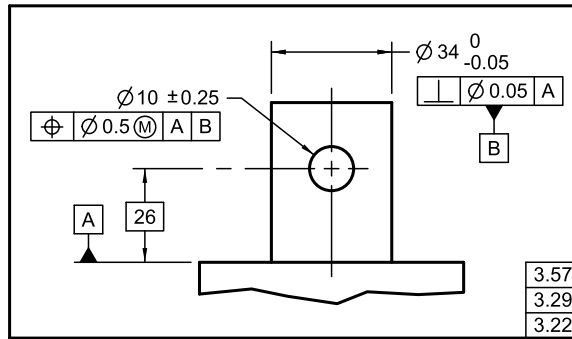

3.57
3.29
3.22

Figure 3-2 Related and Unrelated Actual Minimum Material Envelope From Figure 3-1

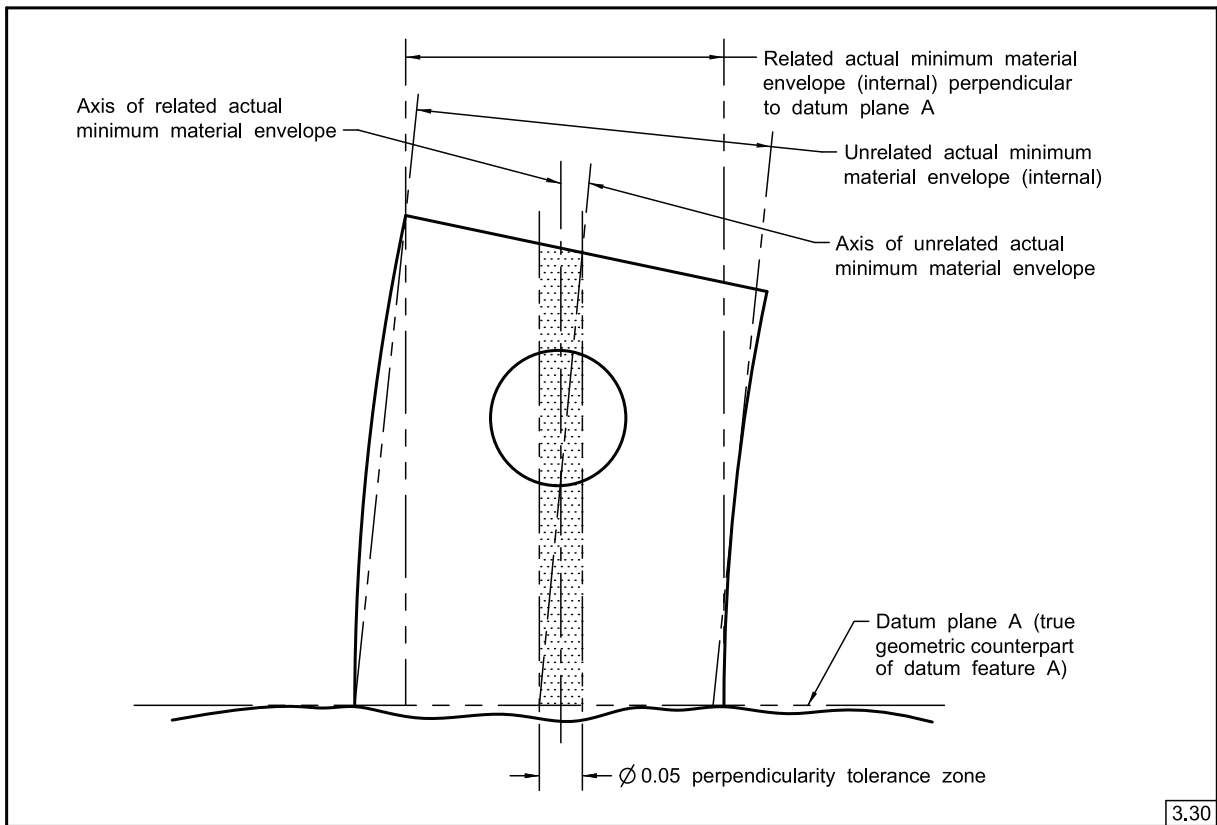

Section 4

Fundamental Rules, Tolerancing Defaults, and Dimensioning Practices

4.1 FUNDAMENTAL RULES

Dimensioning and tolerancing shall clearly define engineering intent and shall conform to the following:

(a) Each feature shall be toleranced. Tolerances may be applied directly to size dimensions. Tolerances shall be applied using feature control frames when feature definition is basic. Tolerances may also be indicated by a note or located in a supplementary block of the drawing format. See ASME Y14.1 and ASME Y14.1M. Those dimensions specifically identified as reference, maximum, minimum, or stock (commercial stock size) do not require the application of a tolerance.

(b) Dimensioning and tolerancing shall be complete so there is full understanding of the characteristics of each feature. Values may be expressed in an engineering drawing or in a CAD product definition data set. See ASME Y14.41. Neither scaling (measuring directly from an engineering drawing graphics sheet) nor assumption of a distance or size is permitted, except in undimensioned drawings, such as loft, printed wiring, templates, and master layouts prepared on stable material, provided the necessary control dimensions are specified. Model data shall be queried when dimensions are not displayed on the model.

(c) Each necessary dimension of an end product shall be shown or defined by model data. No more dimensions than those necessary for complete definition shall be given. The use of reference dimensions on a drawing should be minimized.

(d) Dimensions shall be selected and arranged to suit the function and mating relationship of a part and shall not be subject to more than one interpretation.

(e) The drawing should define a part without specifying manufacturing methods. Thus, only the diameter of a hole is given without indicating whether it is to be drilled, reamed, punched, or made by another operation. However, in those instances where manufacturing, processing, quality assurance, or environmental information is essential to the definition of engineering requirements, the information shall be specified on the drawing or in a document referenced on the drawing.

(f) Nonmandatory processing dimensions shall be identified by an appropriate note, such as **NONMANDATORY (MFG DATA)**. Examples of nonmandatory

data are processing dimensions that provide for finish allowance, shrink allowance, and other requirements, provided the final dimensions are given on the drawing.

(g) Dimensions should be arranged to provide required information for optimum readability.

(h) Dimensions in orthographic views should be shown in true profile views and refer to visible outlines. When dimensions are shown in models, the dimensions shall be applied in a manner that shows the true value.

(i) Wires, cables, sheets, rods, and other materials manufactured to gage or code numbers shall be specified by linear dimensions indicating the diameter or thickness. Gage or code numbers may be shown in parentheses following the dimension.

(j) An implied 90° angle shall apply where center lines and lines depicting features are shown on orthographic views at right angles and no angle is specified. For information on applicable tolerances for implied 90° angles, see [para. 5.1.1.3](#).

(k) An implied 90° basic angle shall apply where center lines of features or surfaces shown at right angles on an orthographic view are located or defined by basic dimensions and no angle is specified. For information on applicable tolerances for implied 90° basic angles, see [para. 5.1.1.4](#).

(l) A zero basic dimension shall apply where axes, center planes, or surfaces are shown coincident on orthographic views and geometric tolerances establish the relationship between the features. On CAD models, the distance is basic when queried model distances are zero and geometric tolerances establish the relationship between the features. For information on applicable tolerances for zero basic dimensions, see [para. 5.1.1.4](#).

(m) UOS, all dimensions and tolerances are applicable at 20°C (68°F) in accordance with ASME B89.6.2. Compensation may be made for measurements made at other temperatures.

(n) UOS, all dimensions and tolerances apply in a free state condition. For exceptions to this rule, see [subsection 7.20](#).

(o) UOS, all tolerances and datum features apply for full depth, length, and width of the feature.

(p) Dimensions and tolerances apply only at the drawing level where they are specified. A dimension specified for a given feature on one level of drawing (e.g., a detail

drawing) is not mandatory for that feature at any other level (e.g., an assembly drawing).

(q) UOS by a drawing/model note or reference to a separate document, the as-designed dimension value does not establish a functional or manufacturing target.

(r) Where a coordinate system is shown on the orthographic views or in the model, it shall be right-handed UOS. Each axis shall be labeled and the positive direction shown.

NOTE: Where a model coordinate system is shown on the drawing, it shall be in compliance with ASME Y14.41.

(s) UOS, elements of a surface include surface texture and flaws (e.g., burrs and scratches). All elements of a surface shall be within the applicable specified tolerance zone boundaries.

4.2 UNITS OF MEASURE

For uniformity, all dimensions illustrated in this Standard are given in SI units UOS. However, the unit of measure selected should be in accordance with the policy of the user.

4.2.1 SI (Metric) Linear Units

The SI linear unit commonly used on engineering drawings is the millimeter.

4.2.2 U.S. Customary Linear Units

The U.S. Customary linear unit commonly used on engineering drawings is the decimal inch.

4.2.3 Identification of Linear Units

On drawings where all dimensions are in millimeters or all dimensions are in inches, individual identification of linear units is not required. However, the drawing shall contain a note stating **UNLESS OTHERWISE SPECIFIED, ALL DIMENSIONS ARE IN MILLIMETERS** (or **IN INCHES**, as applicable).

4.2.4 Combination SI (Metric) and U.S. Customary Linear Units

Where some inch dimensions are shown on a millimeter-dimensioned drawing, the abbreviation **IN** shall follow the inch values. Where some millimeter dimensions are shown on an inch-dimensioned drawing, the abbreviation “mm” shall follow the millimeter values.

4.2.5 Angular Units

Angular dimensions are expressed in degrees; degrees and decimal parts of a degree; or degrees, minutes, and seconds. These dimension units are expressed by the following symbols:

- (a) degrees: °
- (b) minutes: ′

(c) seconds: ″

Where degrees are indicated alone, the numerical value shall be followed by the symbol. Where values less than 1° are specified in minutes or seconds, the number of minutes or seconds shall be preceded by 0° or 0°0′, as applicable. See [Figure 4-1](#). Where decimal values less than 1° are specified, a zero shall precede the decimal value.

4.3 TYPES OF DIMENSIONING

Decimal dimensioning shall be used on drawings except where certain commercial commodities are identified by standardized nominal size designations, such as pipe and lumber sizes.

4.3.1 Millimeter Dimensioning

The following shall be observed when specifying millimeter dimensions:

(a) Where the dimension is less than 1 mm, a zero shall precede the decimal point. See [Figure 4-2](#).

(b) Where the dimension is a whole number, neither the decimal point nor a zero shall be shown. See [Figure 4-2](#).

(c) Where the dimension exceeds a whole number by a decimal fraction of 1 mm, the last digit to the right of the decimal point shall not be followed by a zero. See [Figure 4-2](#).

NOTE: This practice differs for tolerances expressed bilaterally or as limits. See [paras. 5.3.1\(b\)](#) and [5.3.1\(c\)](#).

(d) Neither commas nor spaces shall be used to separate digits into groups in specifying millimeter dimensions on drawings.

4.3.2 Decimal Inch Dimensioning

The following shall be observed when specifying decimal inch dimensions on drawings:

(a) A zero shall not be used before the decimal point for values less than 1 in. See [Figure 4-3](#).

(b) A dimension shall be expressed to the same number of decimal places as its tolerance. Zeros are added to the right of the decimal point where necessary. See [para. 5.3.2](#) and [Figure 4-3](#).

4.3.3 Decimal Points

Decimal points shall be uniform, dense, and large enough to be clearly visible and meet reproduction requirements. Decimal points are placed in line with the bottom of the associated digits.

4.3.4 Default for Conversion and Rounding of Linear Units

UOS, conversion and rounding of U.S. Customary linear units are in accordance with IEEE/ASTM SI 10.

4.4 APPLICATION OF DIMENSIONS

Dimensions may be applied by means of dimension lines, extension lines, chain lines, notes, or leaders from dimensions. Dimensions may also be applied through specifications directed to the appropriate features or contained in a digital data set. See [Figure 4-4](#). Notes may be used to convey additional information. For further information on dimension lines, extension lines, chain lines, leaders, and digital product definition data practices, see ASME Y14.2 and ASME Y14.41.

NOTE: Figures in [Section 4](#) showing application of dimensions are not intended to be complete drawings and illustrate a dimensioning concept defined by the text without indicating datums or tolerancing methods.

4.4.1 Dimension Lines

A dimension line, with its arrowheads, shows the direction and extent of a dimension. Numerals indicate the number of units of a measurement. Dimension lines should be broken for insertion of numerals as shown in [Figure 4-4](#). Where horizontal dimension lines are not broken, numerals may be placed above and parallel to the dimension lines.

NOTE: The following shall not be used as a dimension line: a center line, an extension line, a phantom line, a line that is part of the outline of the object, or a continuation of any of these lines. A dimension line is not used as an extension line, except where a simplified method of coordinate dimensioning is used to define curved outlines. See [Figure 4-33](#).

4.4.1.1 Alignment. Dimension lines should be aligned and grouped for uniform appearance. See [Figure 4-5](#).

4.4.1.2 Spacing. Dimension lines are drawn parallel to the direction of measurement. The space between the first dimension line and the part outline should be not less than 10 mm; the space between succeeding parallel dimension lines should be not less than 6 mm. See [Figure 4-6](#).

NOTE: These spacings are intended as guides only. If the drawing meets the reproduction requirements of the accepted industry or military reproduction specification, nonconformance to these spacing requirements is not a basis for rejection of the drawing.

Where there are several parallel dimension lines, the numerals should be staggered for easier reading. See [Figure 4-7](#).

4.4.1.3 Angle Dimensions. The dimension line of an angle is an arc drawn with its center at the apex of the angle. The dimension line may terminate with one arrowhead and a dimension origin symbol, as shown in [Figure 4-1](#), or with two arrowheads, as shown in [Figure 4-4](#).

4.4.1.4 Crossing Dimension Lines. Crossing dimension lines should be avoided. Where crossing dimension lines is unavoidable, the dimension lines shall be unbroken.

4.4.2 Extension (Projection) Lines

Extension lines are used to indicate the extension of a surface or point to a location preferably outside the part outline. See [para. 4.4.8](#). On orthographic views, extension lines start with a short visible gap from the outline of the part and extend beyond the outermost related dimension line. See [Figure 4-6](#). Extension lines are drawn perpendicular to dimension lines. Where space is limited, extension lines may be drawn at an oblique angle to clearly illustrate where they apply. Where oblique extension lines are used, the dimension lines shall be shown in the direction in which they apply. See [Figure 4-8](#).

4.4.2.1 Crossing Extension Lines. Wherever practical, extension lines should neither cross one another nor cross dimension lines. To minimize such crossings, the shortest dimension line is shown nearest the outline of the object. See [Figure 4-7](#). Where extension lines must cross other extension lines, dimension lines, or lines depicting features, they are not to be broken. Where extension lines cross arrowheads or dimension lines close to arrowheads, a break in the extension line is permissible. See [Figure 4-9](#).

4.4.2.2 Locating Points or Intersections. When a point is located by extension lines only, the extension lines from surfaces should pass through the point or intersection. See [Figure 4-10](#).

4.4.3 Limited Length or Area Indication

Where it is desired to indicate that a limited length or area of a surface is to receive additional treatment or consideration within limits specified on the drawing, the extent of these limits may be indicated by use of a chain line. See [Figure 4-11](#).

4.4.3.1 Chain Lines. In an appropriate orthographic view or section, a chain line is drawn parallel to the surface profile at a short distance from it. Dimensions are added for length and location. If applied to a surface of revolution, the indication may be shown on one side only. See [Figure 4-11](#), illustration (a). In a model, supplemental geometry may be used to indicate a limited area. An entire feature is indicated in a model by attaching the notation to the feature. See ASME Y14.41.

4.4.3.2 Omitting Chain Line Dimensions. If the chain line clearly indicates the location and extent of the surface area, dimensions may be omitted. See [Figure 4-11](#), illustration (b).

4.4.3.3 Area Indication Identification. Where the desired area is shown on a direct view of the surface, the area is section lined within the chain line boundary and appropriately dimensioned. See [Figure 4-11](#), illustration (c).

4.4.4 Leaders (Leader Lines)

A leader is used to direct a dimension, note, or symbol to the intended place on the drawing. Normally, a leader in an orthographic view terminates in an arrowhead. However, when it is intended for a leader to refer to a surface by ending within the outline of that surface, the leader shall terminate in a dot. A leader should be an inclined straight line except for a short horizontal portion extending to the midheight of the first or last character of the note or dimension. Two or more leaders to adjacent areas on the drawing should be drawn parallel to each other. See [Figure 4-12](#). Leaders in a model terminate in a dot where the leader contacts a surface. Where the leader terminates on the edge of a feature such as a hole, the leader terminates with an arrowhead. See ASME Y14.41.

4.4.4.1 Leader-Directed Dimensions. Leader-directed dimensions are specified individually to avoid complicated leaders. See [Figure 4-13](#). When too many leaders would impair the legibility of the drawing, letters or symbols should be used to identify features. See [Figure 4-14](#).

4.4.4.2 Circle and Arc. When a leader is directed to a circle or an arc, its direction should be radial. See [Figure 4-15](#).

4.4.5 Reading Direction

Reading direction for the specifications in [paras. 4.4.5.1 through 4.4.5.5](#) apply with regard to the orientation of the drawing graphics sheet. For placement in models, see ASME Y14.41.

4.4.5.1 Notes. Notes should be placed to read from the bottom of the drawing.

4.4.5.2 Dimensions. Dimensions shown with dimension lines and arrowheads on orthographic views should be placed to read from the bottom of the drawing. See [Figure 4-16](#).

4.4.5.3 Base Line Dimensioning. Base line dimensions should be shown aligned to their extension lines and read from the bottom or right side of the drawing. See [Figure 4-48](#).

4.4.5.4 Feature Control Frames. Feature control frames should be placed to read from the bottom of the drawing.

4.4.5.5 Datum Feature Symbols. Datum feature symbols should be placed to read from the bottom of the drawing.

4.4.6 Reference Dimensions

The method for identifying a reference dimension (or reference data) on drawings is to enclose the dimension (or data) within parentheses. See [Figures 4-17 and 4-18](#).

4.4.7 Overall Dimensions

When an overall dimension is specified, one intermediate dimension is omitted or identified as a reference dimension. See [Figure 4-17](#). When the intermediate dimensions are more important than the overall dimension, the overall dimension, if used, is identified as a reference dimension. See [Figure 4-18](#).

4.4.8 Dimensioning Within the Outline of a View

Dimensions are usually placed outside the outline of a view. Where directness of application provides clarity, or where extension lines or leader lines would be excessively long, dimensions may be placed within the outline of a view.

4.4.9 Dimensions Not to Scale

Agreement should exist between the pictorial presentation of a feature and its defining dimension. When a change to a feature is made, the following, as applicable, shall be observed:

(a) Where the sole authority for the product definition is a hard-copy original drawing graphics sheet and it is not feasible to update the view of the feature, the out-of-scale defining dimension shall be underlined with a straight thick line. Where a basic dimension symbol is used, the line shall be placed beneath the symbol.

(b) Where the sole authority for the product definition is a model (digital), refer to ASME Y14.41.

4.5 DIMENSIONING FEATURES

Various characteristics and features require unique methods of dimensioning.

4.5.1 Diameters

The diameter symbol shall precede all diameter values. Where the diameters of a number of concentric cylindrical features are specified in orthographic views, such diameters should be dimensioned in a longitudinal view. See [Figure 4-19](#). Where the diameter of a spherical feature is specified, the value is preceded by the spherical diameter symbol. Diameter dimensions in a model may be attached by leader. See ASME Y14.41.

4.5.2 Radii

Each radius value shall be preceded by the appropriate radius symbol. See [Figure 4-20](#). A radius dimension line uses one arrowhead, at the arc end of the dimension line. An arrowhead is never used at the radius center. Where location of the center is important and space permits, a dimension line may be drawn from the radius center with the arrowhead touching the arc, and the dimension placed between the arrowhead and the center. Where space is limited, the dimension line may be extended through the radius center. Where it is inconvenient to place the

arrowhead between the radius center and the arc, it may be placed outside the arc with a leader. Where the center of a radius is not dimensionally located, the center shall not be indicated. See [Figure 4-20](#).

4.5.2.1 Center of Radius. Where a dimension is given to the center of a radius, a small cross should be drawn at the center. Extension lines and dimension lines shall be used to locate the center. See [Figure 4-21](#). Where location of the center is unimportant, the drawing shall clearly show that the arc location is controlled by other dimensioned features such as tangent surfaces. See [Figure 4-22](#).

4.5.2.2 Foreshortened Radii. Where the center of a radius is outside the drawing or interferes with another view on a drawing graphics sheet, the radius dimension line may be foreshortened. See [Figure 4-23](#). The portion of the dimension line extending from the arrowhead is radial relative to the arc. Where the radius dimension line is foreshortened and the center is located by coordinate dimensions, the dimension line locating the center is also foreshortened. Dimension lines may not be foreshortened when dimensioning a model. See ASME Y14.41.

4.5.2.3 True Radius. On an orthographic view, where a radius is dimensioned in a view that does not show the true shape of the radius, "TRUE" is added before or after the radius dimension. See [Figure 4-24](#). This practice is applicable to other foreshortened features in addition to radii. See [Figure 7-29](#). This practice is not applicable to dimensions applied on a model. See ASME Y14.41.

4.5.2.4 Multiple Radii. When a part has a number of radii of the same dimension, a note may be used instead of dimensioning each radius separately.

4.5.2.5 Spherical Radii. When a spherical surface is dimensioned by a radius, the radius dimension shall be preceded by the symbol **SR**. See [Figure 4-25](#).

4.5.3 Chords and Arcs

The dimensioning of chords and arcs shall be as shown in [Figure 4-26](#).

4.5.4 Rounded Ends and Slotted Holes

Features having rounded ends, including slotted holes, should be dimensioned using one of the methods shown in [Figure 4-27](#). For fully rounded ends, the radii are indicated but not dimensioned. For features with partially rounded ends, the radii are dimensioned. See [Figure 4-28](#).

4.5.5 Rounded Corners

Where corners are rounded, dimensions define the edges, and the arcs are tangent. See [Figure 4-29](#).

4.5.6 Outlines Consisting of Arcs

A curved outline composed of two or more arcs may be dimensioned by giving the radii of all arcs and locating the necessary centers with coordinate dimensions. Other radii are located on the basis of their points of tangency. See [Figure 4-30](#).

4.5.7 Irregular Outlines

Irregular outlines may be dimensioned as shown in [Figures 4-31](#) and [4-32](#). Circular or noncircular outlines may be dimensioned by the rectangular coordinate method or the offset method. See [Figure 4-31](#). Coordinates are dimensioned from base lines. Where many coordinates are required to define an outline, the vertical and horizontal coordinate dimensions may be tabulated, as in [Figure 4-32](#). The outline may also be defined by mathematical formula or digital data.

4.5.8 Grid System

Curved pieces that represent patterns may be defined by a grid system with numbered grid lines.

4.5.9 Symmetrical Outlines

Symmetrical outlines may be dimensioned on one side of the center line of symmetry when using a drawing graphics sheet. Such is the case when, due to the size of the part or space limitations, only part of the outline can be conveniently shown. See [Figure 4-33](#). Half of the outline of the symmetrical shape is shown, and symmetry is indicated by applying symbols for part symmetry to the center line. See ASME Y14.2.

4.5.10 Round Holes

Round holes are dimensioned as shown in [Figure 4-34](#). If it is not clear that a hole goes through, the abbreviation "THRU" follows a dimension. Where multiple features are involved, additional clarification may be required. The depth dimension of a blind hole is the depth of the full diameter from the outer surface of the part. Where the depth dimension is not clear, as from a curved surface, the depth should be dimensioned using dimension and extension lines rather than notation. For methods of specifying blind holes, see [Figure 4-34](#).

4.5.11 Counterbored Holes

Counterbored holes may be specified as shown in [Figure 4-35](#), and, where applicable, a fillet radius may be specified. Where control of the counterbored depth is required, it may be specified using depth dimension following the depth symbol. Where the thickness of the remaining material has significance, this thickness (rather than the depth) is dimensioned. For holes having more than one counterbore, see [Figure 4-36](#). The relationship of the counterbore

and the hole shall be specified. See [Figures 10-25 through 10-27](#).

4.5.12 Countersunk and Counterdrilled Holes

For countersunk holes, the diameter and included angle of the countersink are specified. Other methods of specifying a countersink, such as specifying a gage diameter or a depth in combination with other parameters, may be used. For counterdrilled holes, the diameter and depth of the counterdrill are specified. Specifying the included angle of the counterdrill is optional. See [Figure 4-37](#). The depth dimension is the depth of the full diameter of the counterdrill from the outer surface of the part.

4.5.13 Chamfered and Countersunk Holes on Curved Surfaces

Where a hole is chamfered or countersunk on a curved surface, the diameter specified applies at the minor diameter of the chamfer or countersink. See [Figure 4-38](#).

4.5.14 Spotfaces

Where the diameter of a spotface is specified, the depth or the remaining thickness of material may be specified. If no depth or remaining thickness of material is specified, the spotface is the minimum depth necessary to clean up the surface to the specified diameter. Where applicable, a fillet radius may be indicated for the spotface. The spotface diameter is the distance across the flat and does not include any fillet that may be specified. In some cases, such as with a through hole, a notation may be necessary to indicate the surface to be spotfaced. See [Figure 4-39](#). A spotface may be specified by a note and need not be shown pictorially.

4.5.15 Machining Centers

When machining centers are to remain on the finished part, this is indicated by a note or dimensioned on the drawing. See ASME B94.11M.

4.5.16 Chamfers

Chamfers are dimensioned by a linear dimension and an angle, or by two linear dimensions. See [Figures 4-40 through 4-43](#). When an angle and a linear dimension are specified, the linear dimension is the distance from the indicated surface of the part to the start of the chamfer. See [Figure 4-40](#).

4.5.16.1 Chamfers Specified by Note. A note may be used to specify 45° chamfers on perpendicular surfaces. See [Figure 4-41](#). This method is used only with 45° chamfers, as the linear value applies in either direction.

4.5.16.2 Round Holes. Where the edge of a round hole is chamfered, the practice of [para. 4.5.16.1](#) should be followed, except where the chamfer diameter requires

dimensional control. See [Figure 4-42](#). This type of control may also be applied to the chamfer diameter on a shaft.

4.5.16.3 Nonperpendicular Intersecting Surfaces.

Two acceptable methods of dimensioning chamfers for surfaces intersecting at other than right angles are shown in [Figure 4-43](#).

4.5.17 Keyseats

Keyseats are dimensioned by width, depth, location, and, if required, length. The depth may be dimensioned from the opposite side of the shaft or hole. See [Figure 4-44](#).

4.5.18 Knurling

Knurling is specified in terms of type, pitch, and diameter before and after knurling. Where control is not required, the diameter after knurling is omitted. Where only a portion of a feature requires knurling, the location and length of the knurl shall be specified. See [Figure 4-45](#).

4.5.18.1 Knurling for Press Fit. Where knurling is required to provide a press fit between parts, a note that specifies the type of knurl, its pitch, the toleranced diameter of the feature before knurling, and the minimum acceptable diameter after knurling shall be included. Where needed, the maximum diameter after knurling may also be specified. See [Figure 4-46](#).

4.5.18.2 Knurling Standard. For information on inch knurling, see ASME B94.6.

4.5.19 Rod and Tubing Details

Rods and tubing should be defined in three coordinate directions and toleranced using geometric tolerances. They may be dimensioned by specifying the straight lengths, bend radii, angles of bend, and angles of twist for all portions of each feature. In orthographic views, this may be done by means of auxiliary views, tabulation, or supplementary data. In a model, the true geometry may be used to define the shape.

4.5.20 Screw Threads

Methods of specifying and dimensioning screw threads are covered in ASME Y14.6.

4.5.21 Surface Texture

Methods of specifying surface texture requirements are covered in ASME Y14.36M. For additional information, see ASME B46.1.

4.5.22 Involute Splines

Methods of specifying involute spline requirements are covered in the ANSI B92 series of standards.

4.5.23 Castings, Forgings, and Molded Parts

Methods of specifying requirements peculiar to castings, forgings, and molded parts are covered in ASME Y14.8.

4.6 LOCATION OF FEATURES

Rectangular coordinate or polar coordinate dimensions locate features with respect to one another, and as a group or individually from a datum, a datum reference frame, or an origin. The features that establish this datum, datum reference frame, or origin shall be identified. For tolerances on location, see [Sections 10, 11, and 12](#). Round holes or other features of symmetrical contour may be located by specifying distances, or distances and directions to the feature centers from a datum, a datum reference frame, or an origin.

4.6.1 Rectangular Coordinate Dimensioning

Where rectangular coordinate dimensioning is used to locate features, linear dimensions specify distances in coordinate directions from two or three mutually perpendicular planes. See [Figure 4-47](#). Coordinate dimensioning shall clearly indicate which features of the part establish these planes. For methods to accomplish this using datum features, see [Figures 7-2 and 7-14](#).

4.6.2 Rectangular Coordinate Dimensioning Without Dimension Lines

On orthographic views, dimensions may be shown on extension lines without the use of dimension lines or arrowheads. The base lines are indicated as zero coordinates. See [Figure 4-48](#).

4.6.3 Tabular Dimensioning

Tabular dimensioning is a type of rectangular coordinate dimensioning in which dimensions from mutually perpendicular planes are listed in a table on the drawing rather than on the pictorial delineation. See [Figure 4-49](#). Tables may be prepared in any suitable manner that adequately locates the features.

4.6.4 Polar Coordinate Dimensioning

When polar coordinate dimensioning is used to locate features, a linear dimension and an angular dimension specify a distance from a fixed point at an angular direction from two or three mutually perpendicular planes. The fixed point is the intersection of these planes. See [Figure 4-50](#).

4.6.5 Repetitive Features or Dimensions

Repetitive features or dimensions may be specified by the use of an “X” in conjunction with a numeral to indicate the number of places required. See [Figures 4-51 and 4-52](#). Where used with a basic dimension, the “X” may be placed either inside or outside the basic dimension frame. No space is used between the number of occurrences and the “X.” A space is used between the “X” and the dimension. See [Figures 7-46 and 10-17](#).

4.6.5.1 Series and Patterns. Features, such as holes and slots, that are repeated in a series or pattern may be specified by giving the required number of features and an “X” followed by the size dimension of the feature. A space is used between the “X” and the dimension. See [Figures 4-51 and 4-52](#).

4.6.5.2 Spacing. Equal spacing of features in a series or pattern may be specified by giving the required number of spaces and an “X,” followed by the applicable dimension. A space is used between the “X” and the dimension. See [Figure 4-52](#). When it is difficult to distinguish between the dimension and the number of spaces, as in [Figure 4-52](#), illustration (a), one space may be dimensioned and identified as reference.

4.6.6 Use of “X” to Indicate “By”

An “X” may be used to indicate “by” between coordinate dimensions as shown in [Figure 4-41](#). In such cases, the “X” shall be preceded and followed by one character space.

NOTE: When the practices described in [paras. 4.6.5 and 4.6.6](#) are used on the same drawing, care shall be taken to ensure that each usage is clear.

Figure 4-1 Angular Units

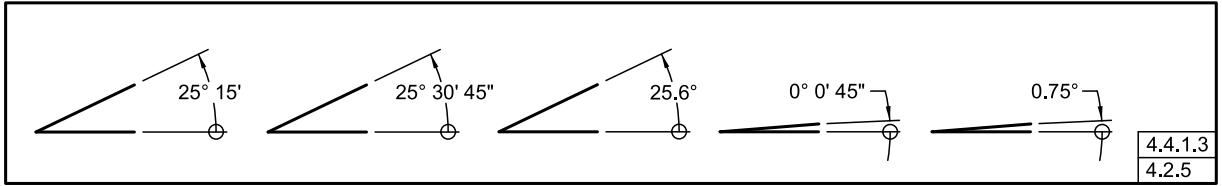

Figure 4-2 Millimeter Dimensions

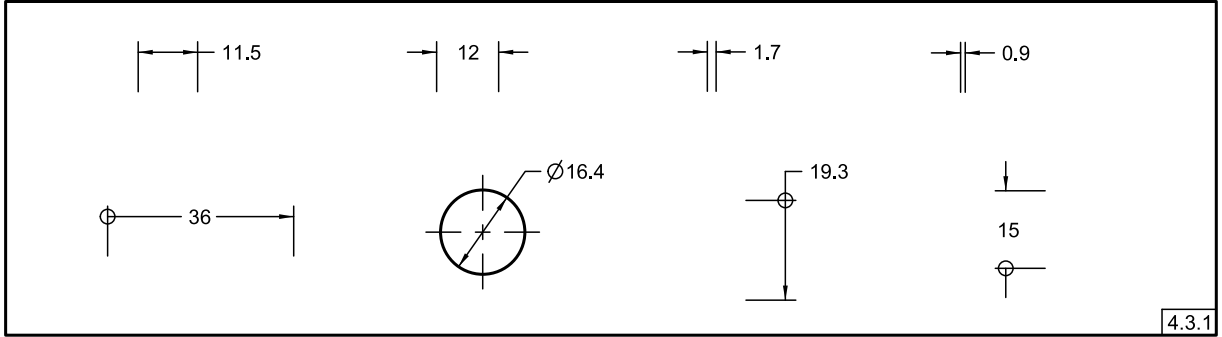

Figure 4-3 Decimal Inch Dimensions

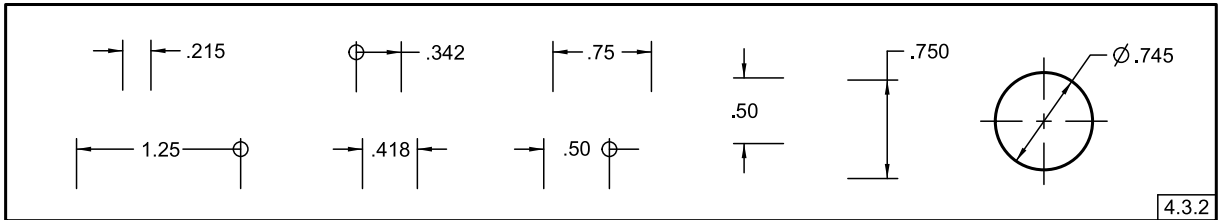

Figure 4-4 Application of Dimensions

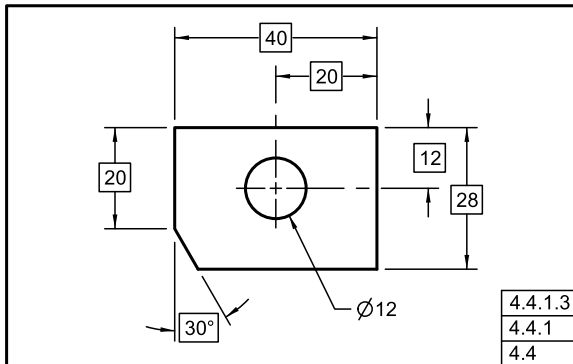

Figure 4-5 Grouping of Dimensions

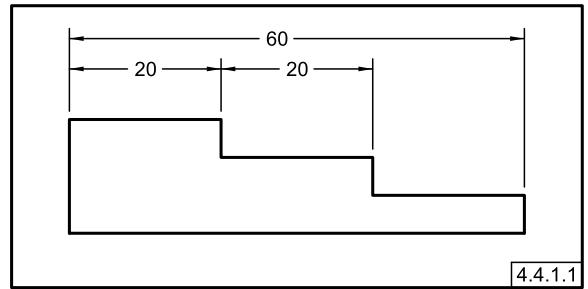

Figure 4-6 Spacing of Dimension Lines

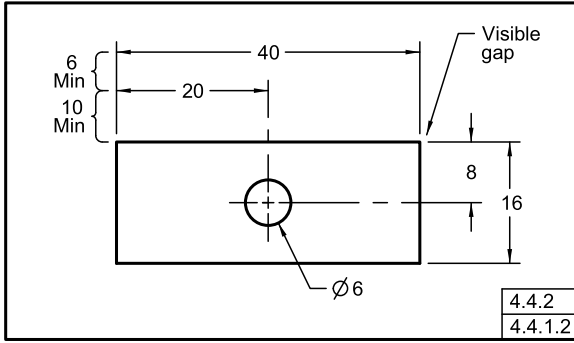

Figure 4-10 Point Locations

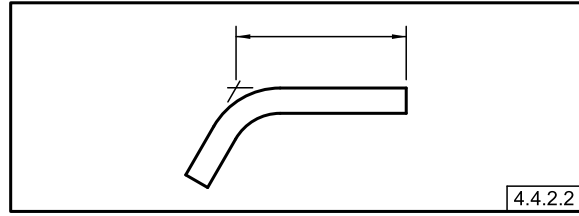

Figure 4-7 Staggered Dimensions

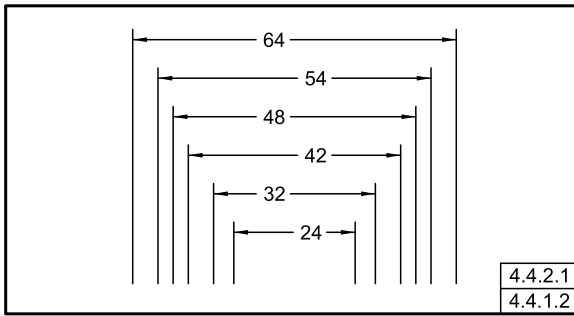

Figure 4-8 Oblique Extension Lines

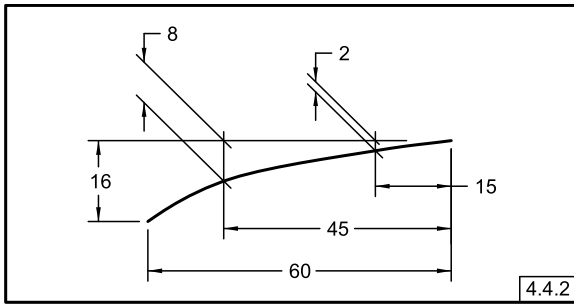

Figure 4-9 Breaks in Extension Lines

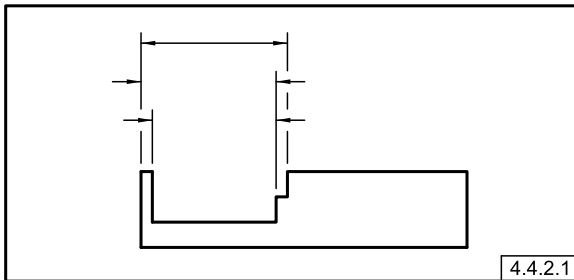

Figure 4-11 Limited Length or Area Indication

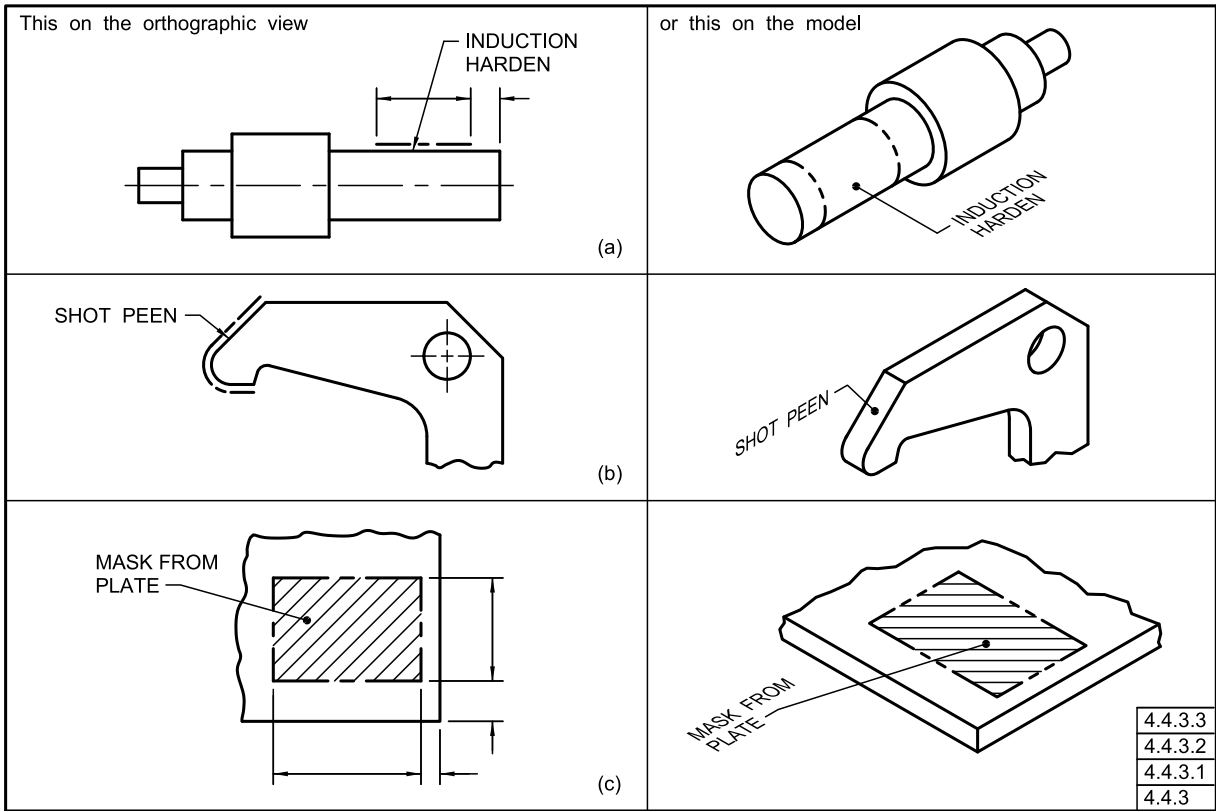

Figure 4-12 Leaders

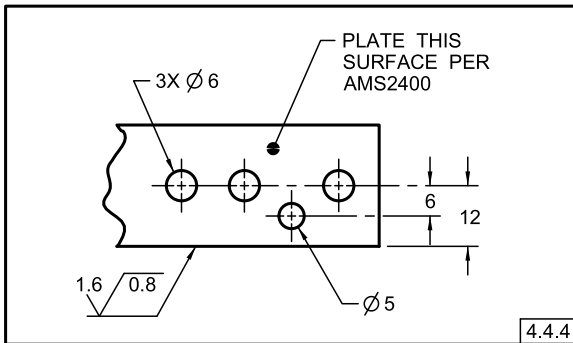

Figure 4-13 Leader-Directed Dimensions

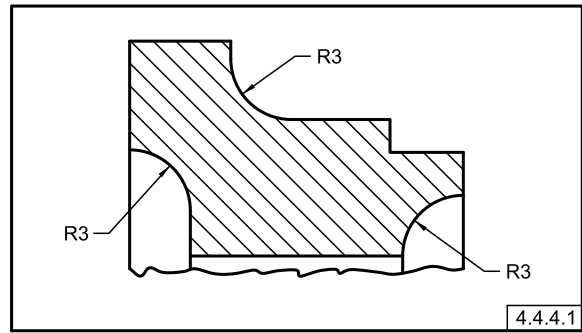

Figure 4-14 Minimizing Leaders

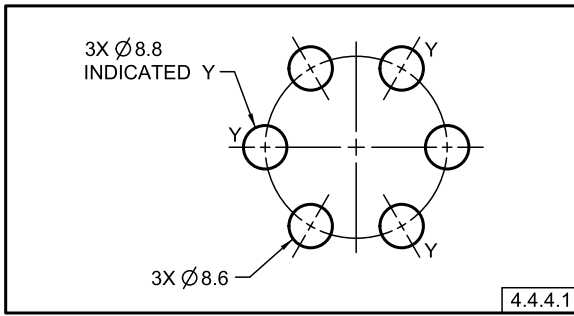

Figure 4-15 Leader Directions

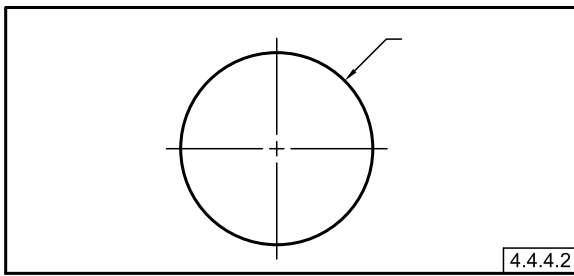

Figure 4-16 Reading Directions

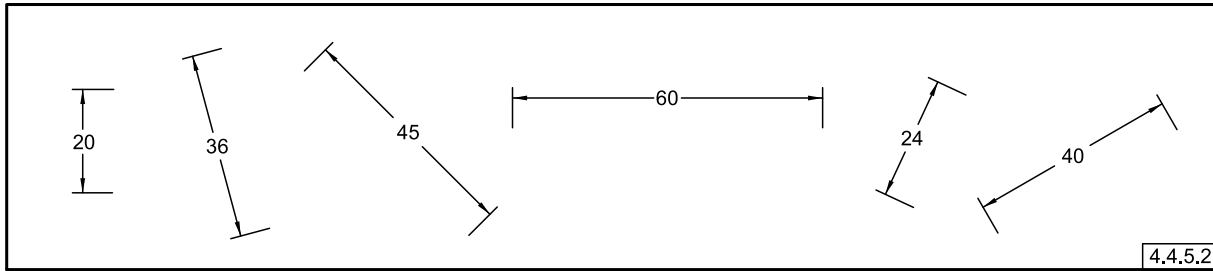

Figure 4-17 Intermediate Reference Dimension

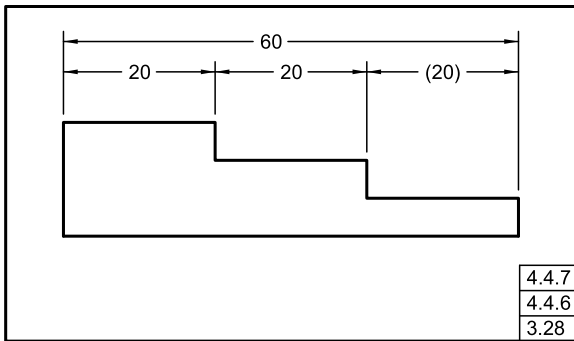

Figure 4-18 Overall Reference Dimension

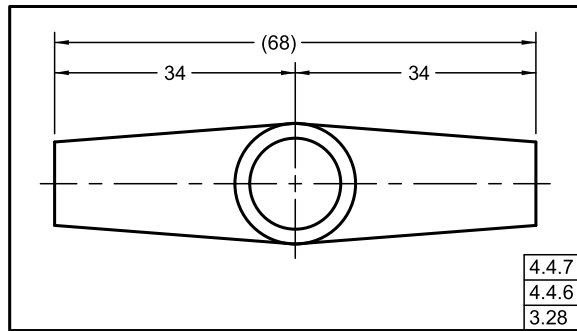

Figure 4-19 Diameters

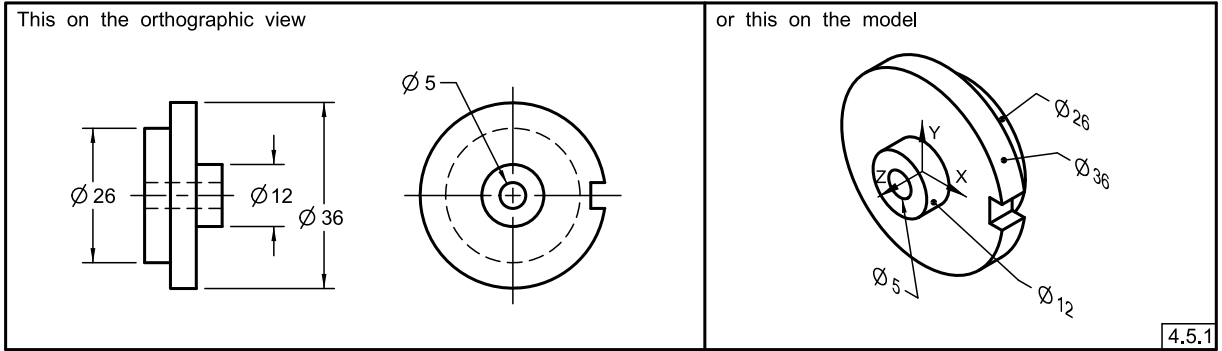

Figure 4-20 Radii

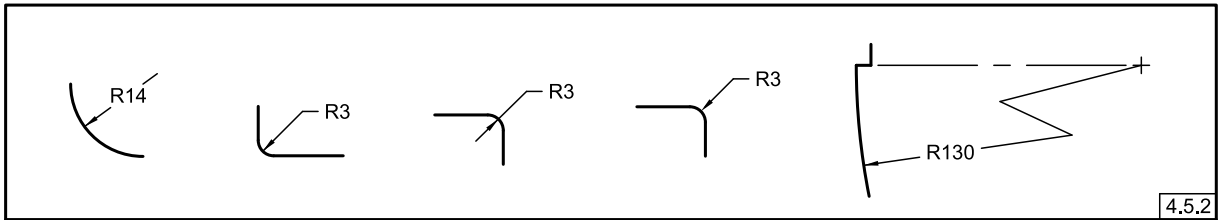

Figure 4-21 Radius With Located Center

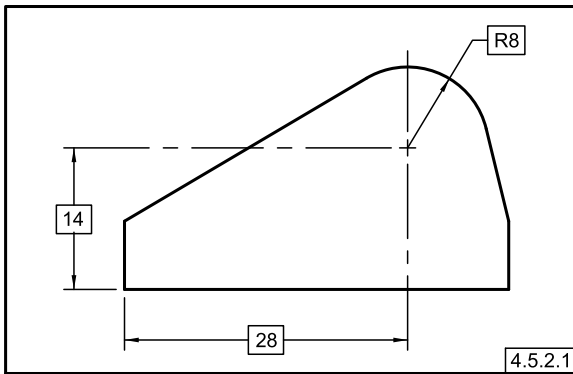

Figure 4-22 Radii With Unlocated Centers

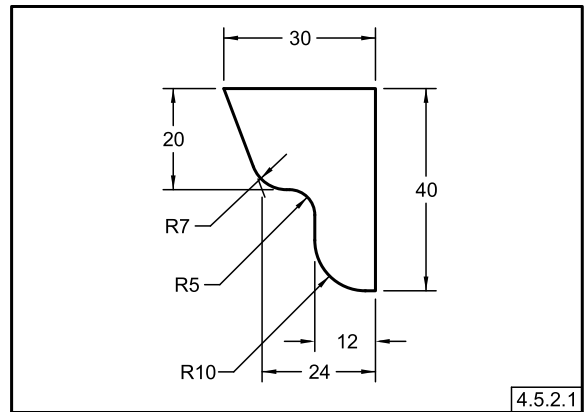

Figure 4-23 Foreshortened Radii

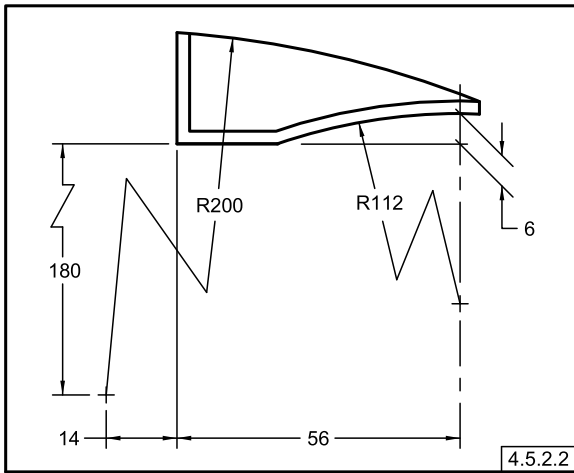

Figure 4-24 True Radius

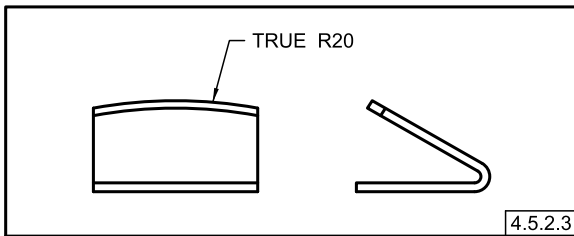

Figure 4-25 Spherical Radius

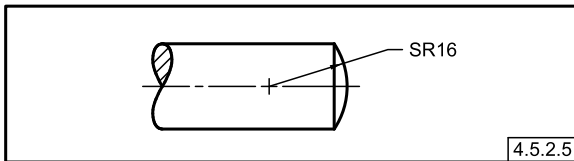

Figure 4-26 Dimensioning Arcs and Chords

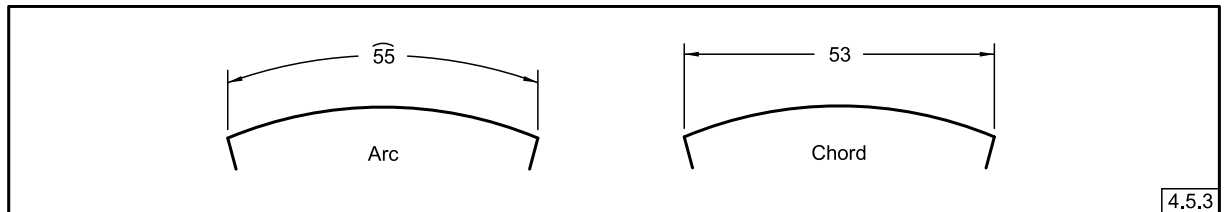

Figure 4-27 Slotted Holes

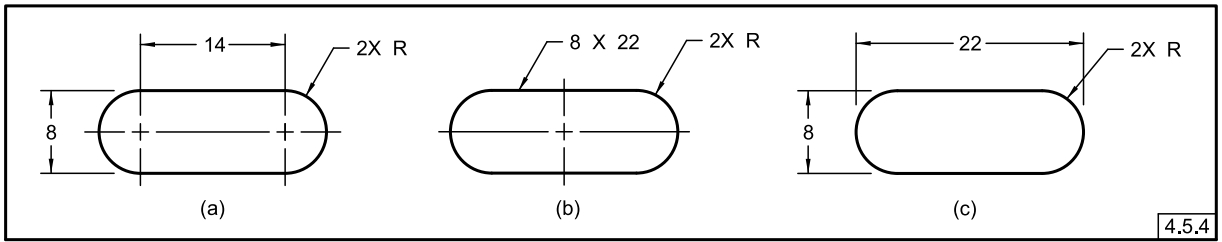

Figure 4-28 Partially Rounded Ends

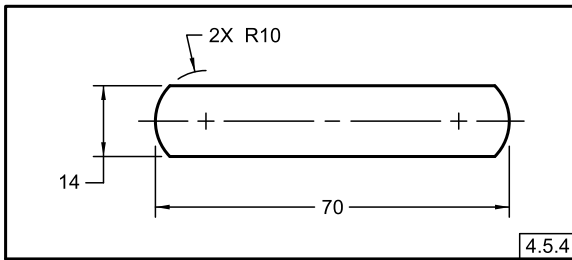

Figure 4-29 Rounded Corners

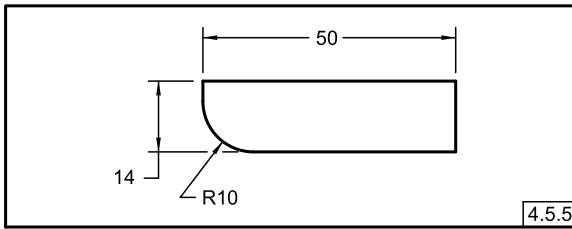

Figure 4-30 Circular Arc Outline

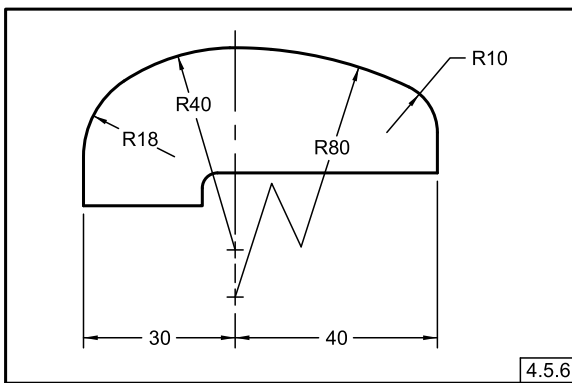

Figure 4-31 Coordinate or Offset Outline

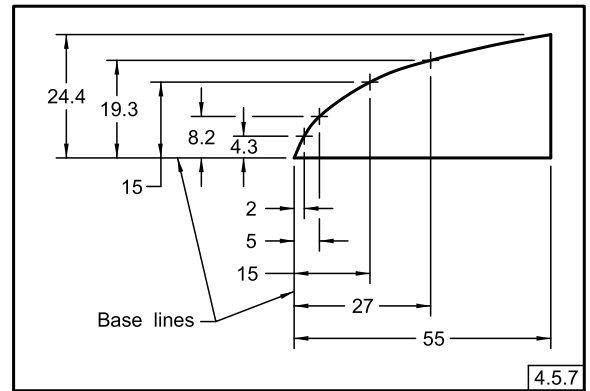

Figure 4-32 Tabulated Outline

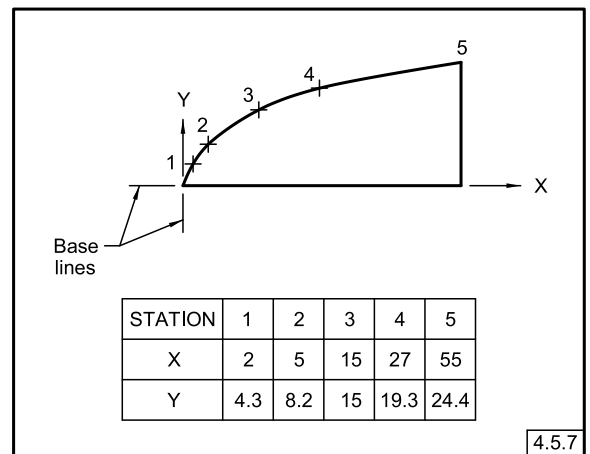

Figure 4-33 Symmetrical Outline

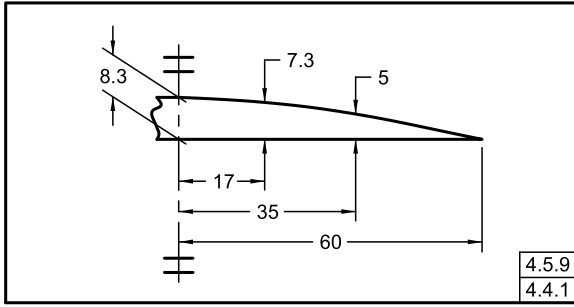

Figure 4-34 Round Holes

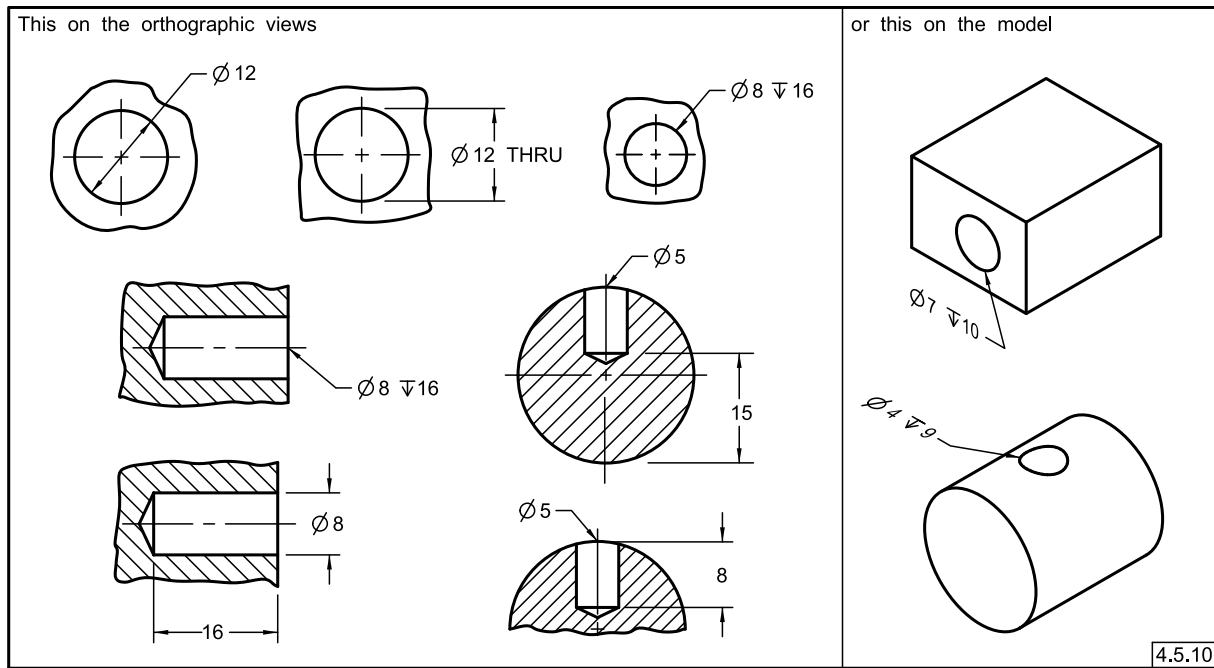

Figure 4-35 Counterbored Holes

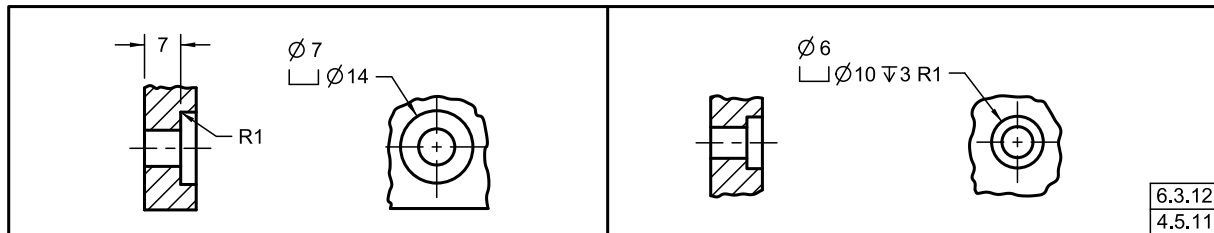
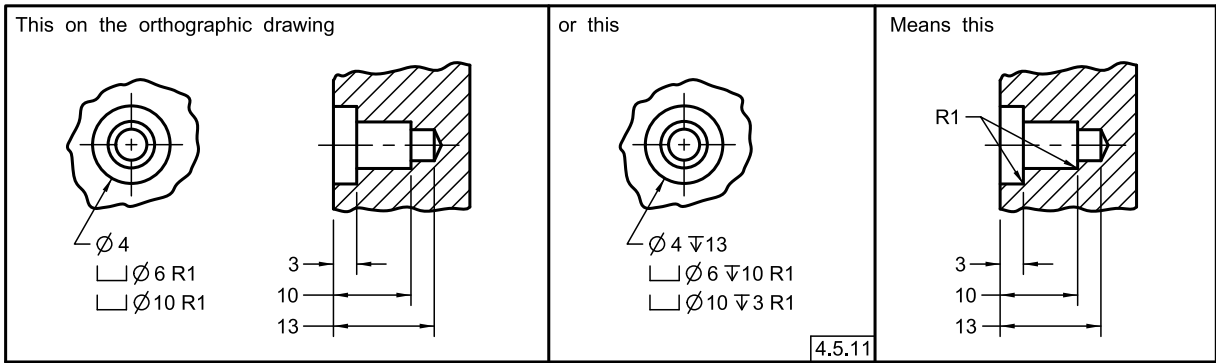
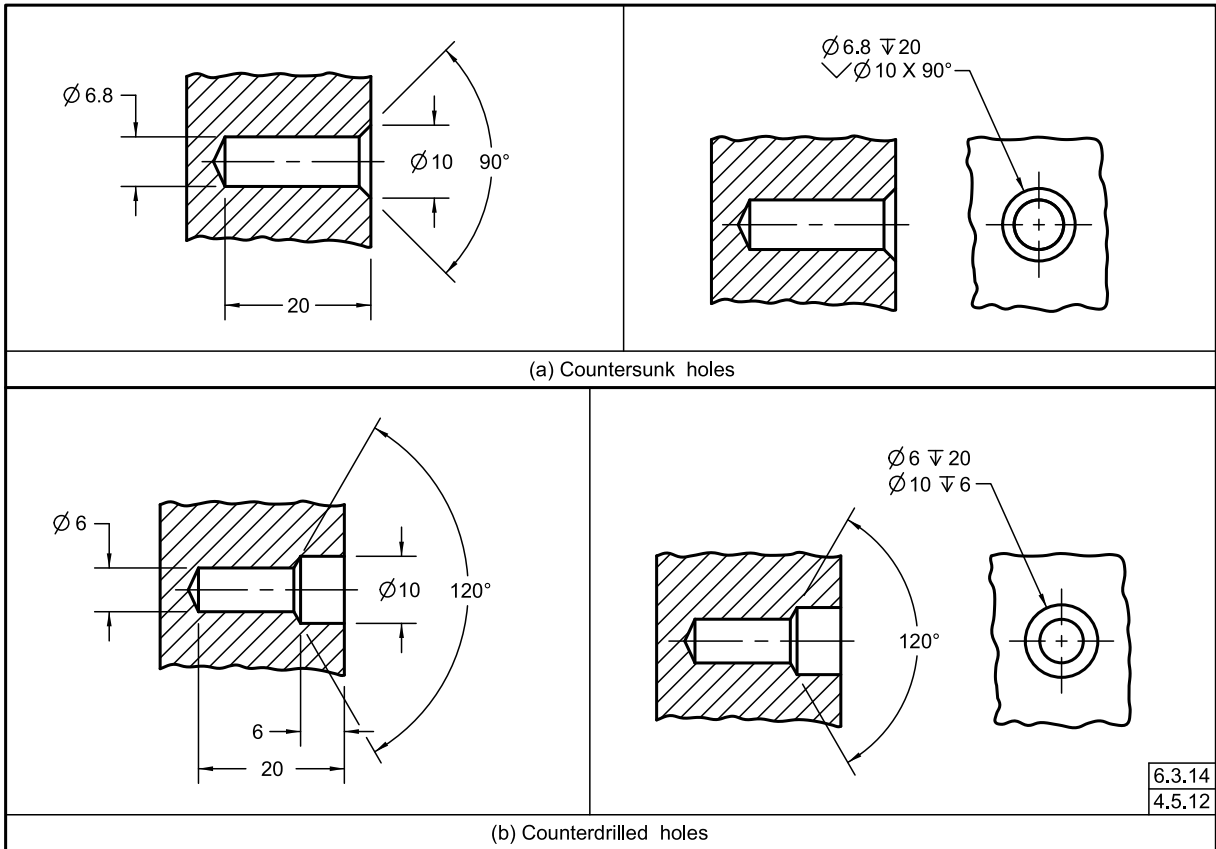

Figure 4-36 Holes With Multiple Counterbores



4.5.11

Figure 4-37 Countersunk and Counterdrilled Holes



6.3.14
4.5.12

Figure 4-38 Countersink on a Curved Surface

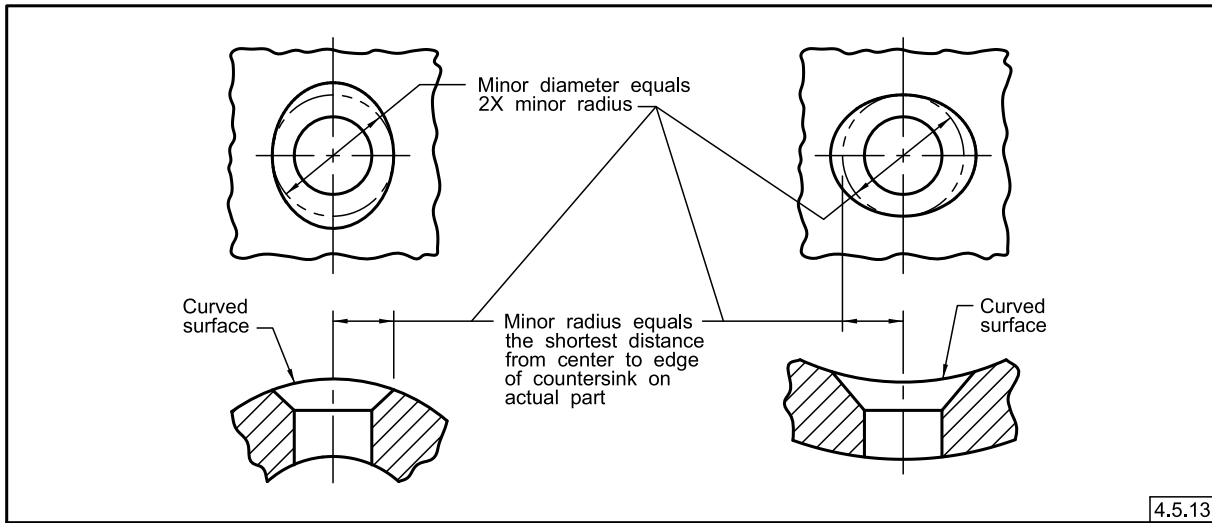

Figure 4-39 Spotfaced Holes

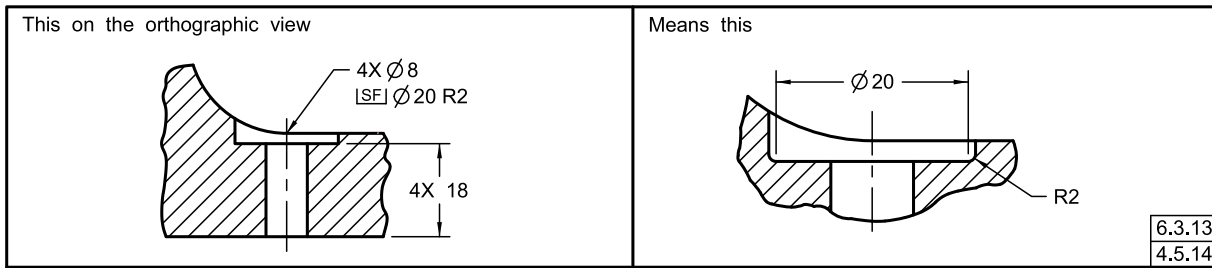

Figure 4-40 Chamfers

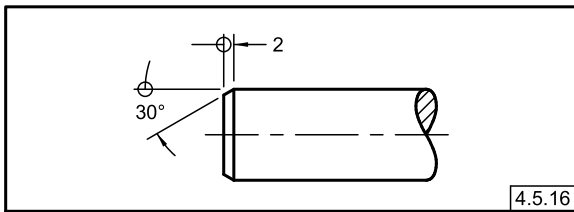

Figure 4-41 45° Chamfer

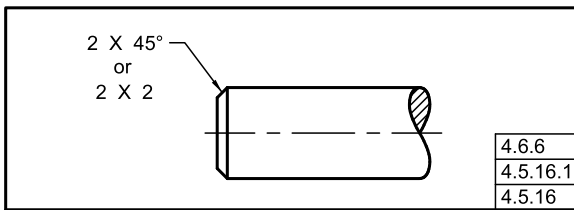

Figure 4-42 Internal Chamfers

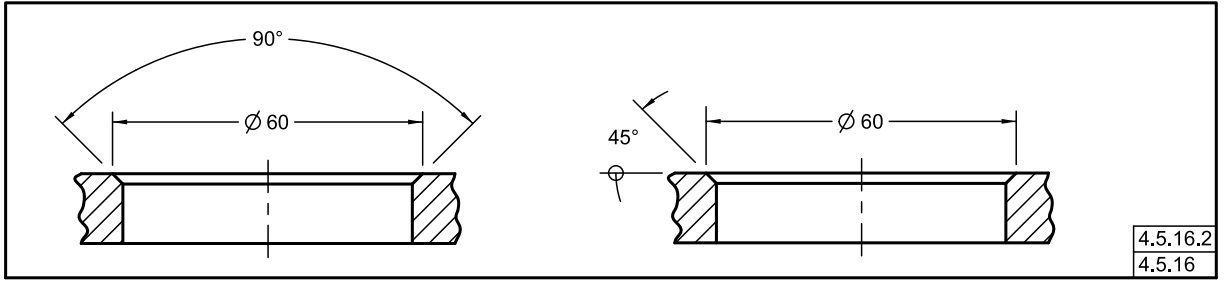

Figure 4-43 Chamfers Between Surfaces at Other Than 90°

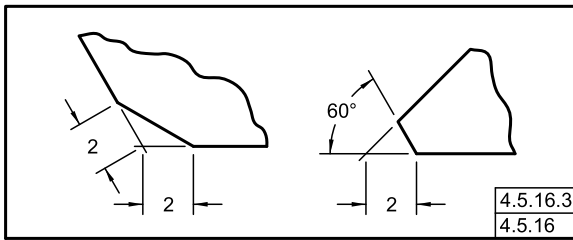

Figure 4-46 Knurls for Press Fits

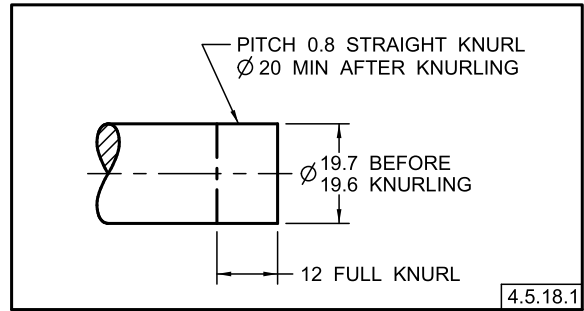

Figure 4-44 Keyseats

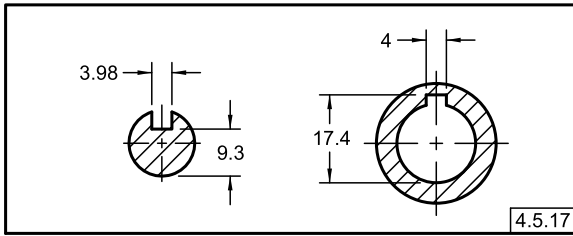

Figure 4-45 Knurls

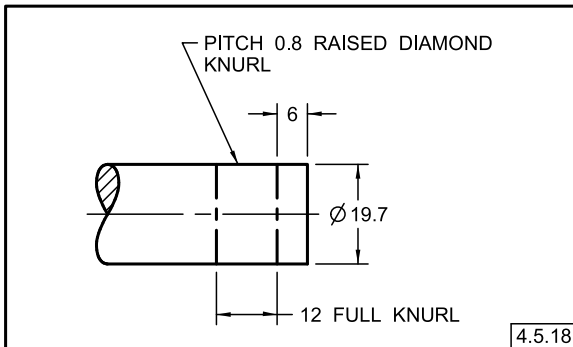
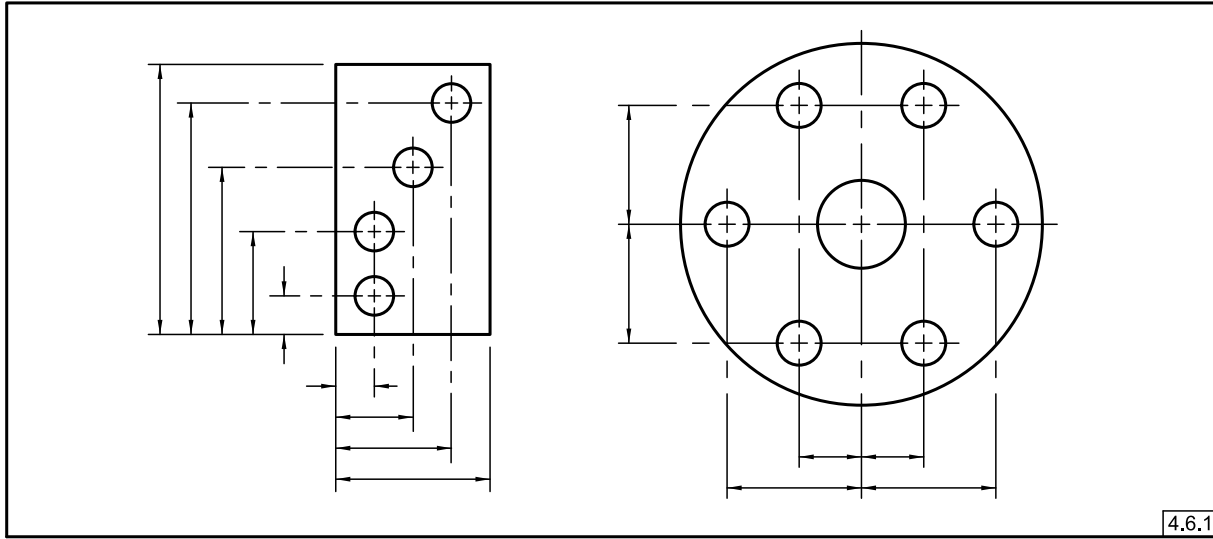
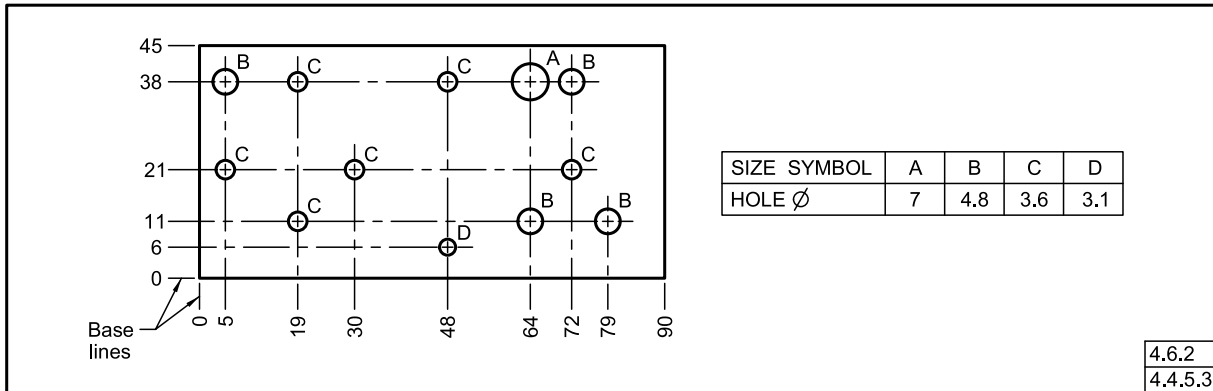

Figure 4-47 Rectangular Coordinate Dimensioning



4.6.1

Figure 4-48 Rectangular Coordinate Dimensioning Without Dimension Lines



4.6.2
4.4.5.3

Figure 4-49 Rectangular Coordinate Dimensioning in Tabular Form

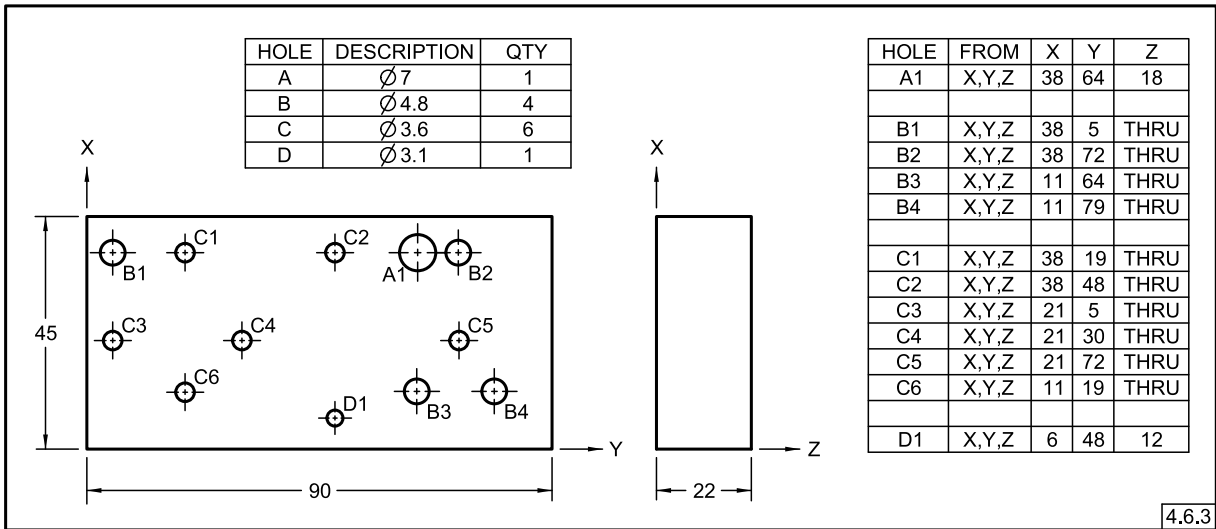

4.6.3

Figure 4-50 Polar Coordinate Dimensioning

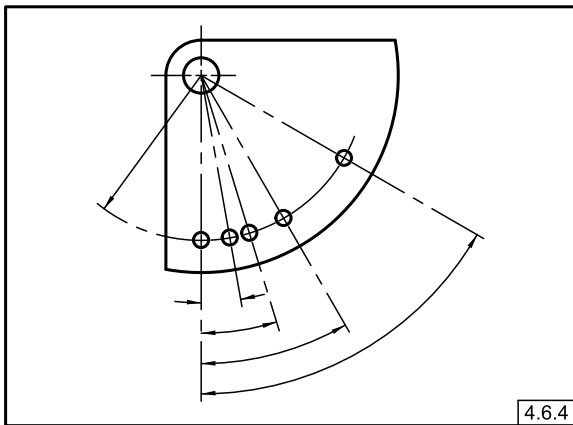

4.6.4

Figure 4-51 Repetitive Features

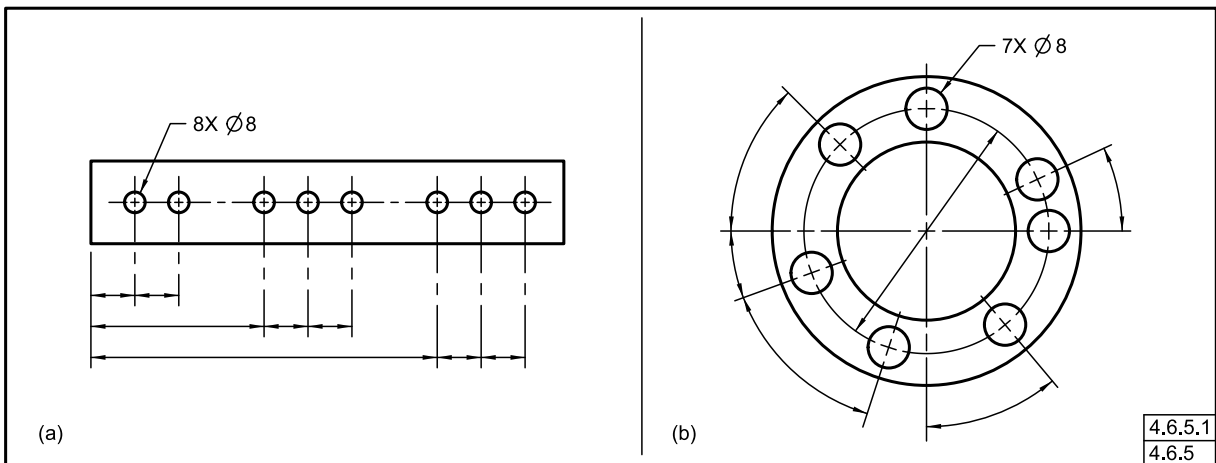

4.6.5.1
4.6.5

Figure 4-52 Repetitive Features and Dimensions

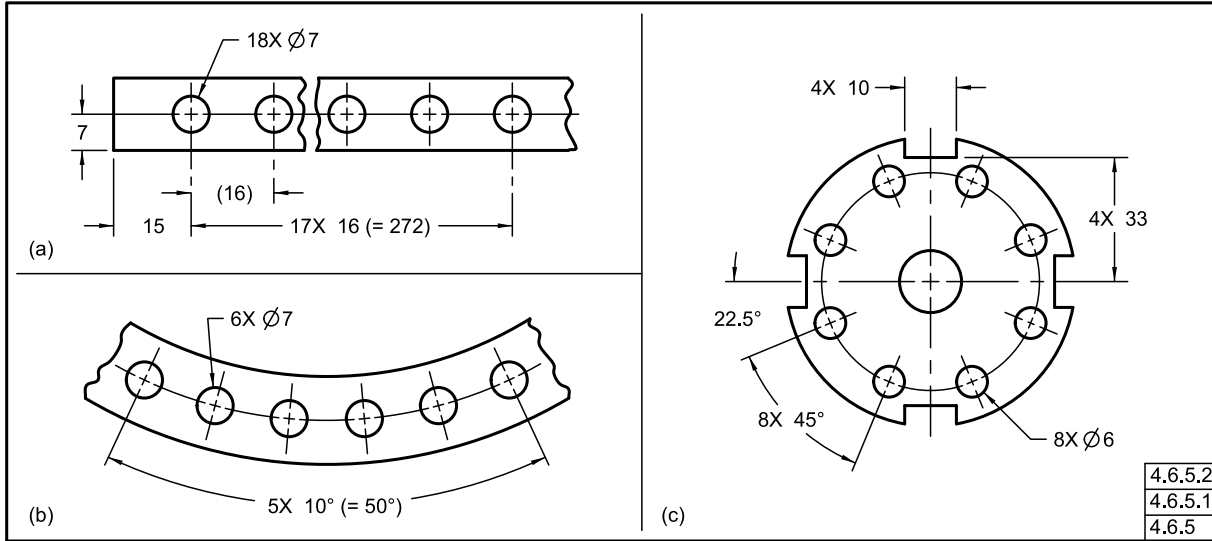

Section 5

Tolerancing, Interpretation of Limits, Limits of Size, and Material Condition Modifiers

5.1 GENERAL

This Section establishes practices for expressing tolerances on linear and angular dimensions, applicability of material condition modifiers on geometric tolerance values, and interpretations governing limits and tolerances.

NOTE: If a model is used to define the tolerances of a part, see ASME Y14.41 for additional requirements.

5.1.1 Application

Tolerances may be expressed as follows:

(a) as direct limits or as tolerance values applied directly to a dimension; see [subsection 5.2](#)

(b) as a geometric tolerance, as described in [Sections 8](#) through [12](#)

(c) in a note or table referring to specific dimensions

(d) as specified in other documents referenced on the drawing for specific features or processes

(e) in a general tolerance block or general note referring to all dimensions on a drawing for which tolerances are not otherwise specified

5.1.1.1 Positional Tolerancing Method. Tolerances on dimensions that locate features of size are specified by the positional tolerancing method described in [Section 10](#). In certain cases, such as locating irregular shaped features, the profile tolerancing method described in [Section 11](#) should be used.

5.1.1.2 Basic Dimensions. Basic dimensions shall be indicated on the orthographic views or in the model in one of the following ways:

(a) applying the basic dimension symbol to each basic dimension. See [Figure 10-1](#), illustrations (a) and (b).

(b) specifying on the drawing (or in a document referenced on the drawing) a general note such as “UNTOLERANCED DIMENSIONS ARE BASIC.” See [Figure 10-1](#), illustration (c).

NOTE: When using this method, a plus/minus tolerance is not allowed via a general tolerance block or notes.

(c) implied basic dimensions of 0° and 90°. See [paras. 4.1\(k\)](#) and [4.1\(l\)](#).

(d) specifying and querying basic dimensions on models. See ASME Y14.41.

5.1.1.3 Tolerances for Implied 90° Angles. Where an implied 90° angle applies, the applicable tolerance is the same as for all other angular features shown on the field of the drawing governed by general angular tolerance notes or general tolerance block values. For the rule regarding implied 90° angles, see [para. 4.1\(j\)](#).

5.1.1.4 Tolerances for Implied 90° or 0° Basic Angles. Where an implied 90° or 0° basic angle applies, the applicable tolerance(s) are provided by a feature control frame or note that governs the location, orientation, profile, or runout of features. For rules regarding implied 90° or 0° basic angles, see [paras. 4.1\(k\)](#) and [4.1\(l\)](#).

5.2 DIRECT TOLERANCING METHODS

Limits and directly applied tolerance values for features of size may be specified using one of the following methods:

(a) *Limit Dimensioning.* The high limit (maximum value) is placed above the low limit (minimum value). When expressed in a single line, the low limit precedes the high limit and a dash separates the two values. See [Figure 5-1](#).

(b) *Plus and Minus Tolerancing.* The dimension is given first, followed by a plus and minus expression of tolerance. See [Figure 5-2](#).

(c) *Geometric Tolerances Directly Applied to Features.* See [Sections 8](#) through [12](#).

5.2.1 Metric Limits and Fits

For metric application of limits and fits, the tolerance may be indicated by a basic size and tolerance symbol as in [Figure 5-3](#). The term “basic size,” when used in regard to limits and fits, is defined as the size to which limits or deviations are assigned. See ANSI B4.2 for complete information on this system.

5.3 TOLERANCE EXPRESSION

The number of decimal places shown in tolerance expressions shall be as explained in paras. 5.3.1 through 5.3.3. For unilateral and bilateral tolerances, the plus value shall be placed above the minus value.

5.3.1 Millimeter Tolerances

Where millimeter dimensions are used on drawings, the following apply:

(a) Where unilateral tolerancing is used and either the plus or minus value is 0, a single zero shall be shown without a plus or minus sign.

$$32 \begin{matrix} 0 \\ -0.02 \end{matrix} \quad \text{or} \quad 32 \begin{matrix} +0.02 \\ 0 \end{matrix}$$

(b) Where bilateral tolerancing is used, both the plus and minus values shall have the same number of decimal places, using zeros where necessary. The dimension value of 32 is not required to have the same number of decimal places as the tolerance values.

This		Not This
32	+0.25 -0.10	32
		+0.25 -0.1

(c) Where limit dimensioning is used and either the maximum or minimum value has digits following a decimal point, the other value shall have zeros added for uniformity.

This	Not This
25.45	25.45
25.00	25

(d) Where basic dimensions are used, associated tolerances contain the number of decimal places necessary for the required level of precision. The basic dimension value observes the practices of para. 4.3.1.

This	Not This
<div style="border: 1px solid black; padding: 2px; display: inline-block;">25</div> with $\text{⊕} \text{ } \text{⌀} \text{ } 0.15 \text{ } \text{Ⓜ} \text{ } \text{A} \text{ } \text{B} \text{ } \text{C}$	<div style="border: 1px solid black; padding: 2px; display: inline-block;">25.00</div> with $\text{⊕} \text{ } \text{⌀} \text{ } 0.15 \text{ } \text{Ⓜ} \text{ } \text{A} \text{ } \text{B} \text{ } \text{C}$

5.3.2 Inch Tolerances

Where inch dimensions are used on a drawing, the following apply:

(a) Where unilateral tolerancing is used and either the plus or minus value is 0, its dimension shall be expressed with the same number of decimal places, and the 0 value shall have the opposite sign of the nonzero value.

This	Not This
.500	.500
+ .005 - .000	+ .005 0

(b) Where bilateral tolerancing is used, both the plus and minus values and the dimension value of .500 shall have the same number of decimal places, using zeros where necessary.

This	Not This
.500 ± .005	.50 ± .005

(c) Where limit dimensioning is used and either the maximum or minimum value has digits following a decimal point, the other value shall have zeros added for uniformity.

This	Not This
.750	.75
.748	.748

(d) Where basic dimensions are used, associated tolerances shall contain the number of decimal places necessary for the required level of precision. There is no requirement for the basic dimension value to be expressed with the same number of decimal places as the tolerance.

<div style="border: 1px solid black; padding: 2px; display: inline-block;">1.000</div> with $\text{⊕} \text{ } \text{⌀} \text{ } .005 \text{ } \text{Ⓜ} \text{ } \text{A} \text{ } \text{B} \text{ } \text{C}$	or	<div style="border: 1px solid black; padding: 2px; display: inline-block;">1.00</div> with $\text{⊕} \text{ } \text{⌀} \text{ } .005 \text{ } \text{Ⓜ} \text{ } \text{A} \text{ } \text{B} \text{ } \text{C}$
--	----	---

5.3.3 Angle Tolerances

Where angle dimensions are used, both the plus and minus values and the angle have the same number of decimal places. Values less than 1° shall include a leading zero.

This	Not This
25.0° ± 0.2°	25° ± .2°
25° ± 0°30'	25° ± 30'

5.4 INTERPRETATION OF LIMITS

All dimensional limit values are absolute. Dimensional limit values, regardless of the number of decimal places, are used as if they were continued with zeros.

12.2	means	12.20...0
12.0	means	12.00...0
12.01	means	12.010...0

5.4.1 Plated or Coated Parts

Where a part is to be plated or coated, the drawing or referenced document shall specify whether the dimensions apply before or after plating. Typical examples of notes are the following:

- (a) **DIMENSIONAL LIMITS APPLY AFTER PLATING.**
- (b) **DIMENSIONAL LIMITS APPLY BEFORE PLATING.**

NOTE: For processes other than plating, substitute the appropriate term.

5.5 SINGLE LIMIT TOLERANCED DIMENSIONS

MIN or MAX shall be placed after a dimension when other elements of the design determine the other unspecified limit. Single limit tolerances on dimensions may be used where the intent is clear, and the unspecified limit can be zero or approach infinity without resulting in a condition detrimental to the design. Examples of where single limit tolerance dimensions may be used include depths of holes, lengths of threads, corner radii, and chamfers.

5.6 TOLERANCE ACCUMULATION BETWEEN SURFACES

Tolerance accumulation between surfaces can occur as a result of datum selection, profile tolerances applied to features, and datum feature references in the profile tolerances. See [Figures 5-4](#) and [5-5](#). The use of profile tolerances for location of surfaces is the preferred practice and can minimize tolerance accumulation without regard to how the basic location dimensions are applied. In the case of an undimensioned model, all queries for basic values should be made in relation to the datums referenced in the applicable feature control frames. Planar feature-to-feature relationships as shown in [Figures 5-4](#) and [5-5](#), where neither is a referenced datum feature, do not establish a requirement unless a feature-relating tolerance is applied. For information about tolerance accumulation related to directly applied tolerances, see [Mandatory Appendix I](#).

5.7 DIMENSIONS RELATED TO AN ORIGIN

In certain cases, it is necessary to indicate that a dimension between two features shall originate from one of the two features and not the other. One method that may be used to accomplish this is to apply the dimension origin symbol. Where the dimension origin symbol is applied, the high points of the surface indicated as the origin define a plane for measurement. The dimensions related to the origin are taken from the point, plane, or axis and define a zone within which the other features shall lie. In [Figure 5-6](#), the dimension origin symbol indicates that the dimension originates from the plane established by the shorter surface and dimensional limits apply to the

other surface. Without this indication, the longer surface could have been selected as the origin, thus permitting a greater angular variation between surfaces. The dimension origin symbol by itself does not establish form control on the origin surface. Form and orientation tolerances may be required for fit and function.

NOTE: Application of the dimension origin symbol does not establish a datum reference frame as described in [Section 7](#).

5.8 LIMITS OF SIZE

UOS, the limits of size of an individual regular feature of size define the extent of allowable variation of geometric form, as well as size. The actual local size of an individual feature of size shall be within the specified limits of size.

5.8.1 Rule #1: The Envelope Principle (Variations of Form)

The form of an individual regular feature of size is controlled by its limits of size to the extent prescribed in (a) through (e) below and illustrated in [Figure 5-7](#).

(a) The surface or surfaces of a regular feature of size shall not extend beyond an envelope that is a boundary of perfect form at MMC. This boundary is the true geometric form represented by the drawing views or model. No elements of the produced surface shall violate this boundary unless the requirement for perfect form at MMC has been removed. There are several methods of overriding Rule #1 that are covered in [paras. 5.8.2, 5.8.3, 8.4.1.3, 8.4.2.1, and 8.5](#).

(b) Where the actual local size of a regular feature of size has departed from MMC toward LMC, a local variation in form is allowed equal to the amount of such departure.

(c) There is no default requirement for a boundary of perfect form at LMC, but a requirement may be invoked as explained in (d). Thus, a regular feature of size produced at its LMC limit of size is permitted to vary from true form to the maximum variation allowed by the boundary of perfect form at MMC.

(d) When a geometric tolerance is specified to apply at LMC, perfect form at LMC is required and there is no requirement for perfect form at MMC. See [para. 10.3.5](#) and [Figure 5-8](#).

(e) Where a portion of a regular feature of size has a localized area(s) that do not contain opposed points, the actual value of an individual distance at any cross section between the unrelated AME to a point on the surface may not violate the LMC limit. See [Figure 5-9](#).

5.8.2 Form Control Does Not Apply (Exceptions to Rule #1)

The control of geometric form prescribed by limits of size does not apply to the following:

(a) items identified as stock, such as bars, sheets, tubing, structural shapes, and other items produced to established industry or government standards that prescribe limits for straightness, flatness, and other geometric characteristics. Unless geometric tolerances are specified on the drawing of a part made from these items, standards for these items govern the surfaces that remain in the as-furnished condition on the finished part.

(b) tolerances applied with the free state modifier.

(c) when form tolerances of straightness or flatness are applied to a feature of size. See [paras. 8.4.1.3 and 8.4.2.1](#).

(d) when the “independency” symbol is used. See [Figure 5-10](#) and [para. 6.3.24](#).

CAUTION: Without a supplementary form control, the feature form is uncontrolled where the “independency” symbol is applied.

(e) when average diameter is specified. See [subsection 8.5](#).

5.8.3 Relationship Between Individual Features

Limits of size do not control the orientation or location relationship between individual features. Features shown perpendicular, coaxial, or symmetrical to each other shall be adequately toleranced for location and orientation to avoid incomplete product requirements. The necessary tolerances should be specified using the methods given in [Sections 9](#) through [12](#). If it is necessary to establish a boundary of perfect form at MMC to control the relationship between features, one of the following methods shall be used:

(a) Specify a zero tolerance of orientation at MMC, including a datum reference (at MMB if applicable), to control angularity, perpendicularity, or parallelism of the feature. See [para. 9.3.4](#).

(b) Specify a zero positional tolerance at MMC, including any specified datum reference (at MMB if applicable), to control coaxial or symmetrical features. See [paras. 10.6.2.2 and 10.7.1.1](#).

(c) Indicate this control for the features involved by a note such as “PERFECT ORIENTATION (or COAXIALITY or LOCATION OF SYMMETRICAL FEATURES) AT MMC REQUIRED FOR RELATED FEATURES.”

5.8.4 Limits of Size and Continuous Features of Size

The note “CONTINUOUS FEATURE” or the “CF” symbol shall be used to identify a group of two or more features of size when there is a requirement that they be treated geometrically as an individual feature of size. See [Figures 5-11](#) through [5-13](#) and [10-49](#). Continuous feature application to nonsize features is explained in [para. 6.3.23](#).

5.9 APPLICABILITY OF MODIFIERS ON GEOMETRIC TOLERANCE VALUES AND DATUM FEATURE REFERENCES

RFS, MMC, or LMC applies to each geometric tolerance value applied on a feature of size. See [Figure 6-25](#). RMB, MMB, or LMB applies to each datum feature reference.

5.9.1 Rule #2: RFS AND RMB DEFAULT

RFS is the default condition for geometric tolerance values. The MMC or LMC material condition modifier may be applied to a geometric tolerance value to override the RFS default. RMB is the default condition for datum feature references. The MMB or LMB material boundary modifier may be applied to a datum feature reference to override the RMB default.

NOTE: Circular runout, total runout, orientation tolerances applied to a surface, profile of a line, profile of a surface, circularity, and cylindricity cannot be modified to apply at MMC or LMC.

5.9.2 Surface Method Default for Geometric Tolerances Modified at MMC or LMC

When there are form deviations on the feature, the deviation in terms of the feature axis or feature center plane may not be equivalent to the deviation of the surface limited by a VC boundary. See [Figures 10-6 and 10-7](#). The surface method shall take precedence when the tolerances are applied at MMC or LMC. See [para. 10.3.3.1\(a\)](#). The surface method is not applicable when tolerances are applied RFS.

5.9.3 Effect of RFS

When a geometric tolerance is applied on an RFS basis, the specified tolerance is independent of the size of the considered feature of size. A tolerance, other than form, applied RFS on a feature of size establishes a tolerance zone that controls the center point, axis, or center plane of the unrelated AME. A form tolerance applied RFS on a feature of size establishes a tolerance zone that controls the derived median plane or derived median line. The tolerance is limited to the specified value regardless of the size of the unrelated AME.

5.9.4 Effect of MMC

When a geometric tolerance is applied on an MMC basis, the allowable variation is dependent on the specified geometric tolerance and the departure of the considered feature from the MMC size. The specified tolerance establishes the allowable variation when the produced feature is at the MMC limit of size. Additional variation is available when the produced feature departs from MMC. There are two methods for determining the amount of additional tolerance permitted. They are the surface method and

the axis method. See [para. 5.9.2](#) regarding risks associated with the axis method.

5.9.4.1 Explanation of the Surface Method. When a geometric tolerance is applied on an MMC basis, the feature's surface shall not violate the VC boundary. While maintaining the specified size limits of the feature, no element of the surface shall violate the VC boundary. Additional variation is available when the produced feature departs from MMC. The maximum geometric variation is permitted when the produced feature is at LMC and has perfect form. See [Figure 10-8](#).

NOTE: When a geometric tolerance applied at MMC results in a negative VC (i.e., when a 2.0–2.5 internal feature of size has a position tolerance of 3.0, the VC is –1.0), the surface interpretation does not apply.

5.9.4.2 Explanation of the Axis Method. When an orientation or position tolerance is applied on an MMC basis, the feature's axis, center plane, or center point shall not violate the tolerance zone. The tolerance available is the specified value if the unrelated AME is at the MMC limit of size. See [Figure 10-9](#). When the size of the unrelated AME of the feature departs from MMC, the tolerance zone increases. The increase in the tolerance zone is equal to the difference between the specified MMC limit of size and the unrelated AME size. The resulting tolerance zone is equal to the stated geometric tolerance plus the additional tolerance. See [para. 10.3.3.1](#) and [Figure 10-10](#). The total permissible variation in the specified geometric characteristic is maximum when the unrelated AME of the feature is at LMC, unless a maximum ("MAX") is specified in the feature control frame.

5.9.5 Effect of Zero Tolerance at MMC

When a feature of size has a geometric tolerance applied on an MMC basis and the function of the toleranced feature allows, the entire combined effects of size tolerance and geometric tolerance may be assigned as a size tolerance with the geometric tolerance of zero at MMC applied. Where a zero geometric tolerance is applied on an MMC basis, the allowable variation is entirely dependent on the departure of the produced feature from MMC. Variation is only permissible if the produced feature is not at the MMC limit of size. There are two methods for determining the amount of tolerance permitted. They are the surface method and the axis method. See [para. 5.9.2](#) regarding risks associated with the axis method.

5.9.5.1 Explanation of the Surface Method. When a geometric tolerance is applied on a zero tolerance on an MMC basis, the feature's surface shall not violate the VC boundary that is equal to the MMC size. The tolerance available is zero if the produced feature is at the MMC limit of size. When the feature of size departs from MMC, additional geometric variation is permitted. The

maximum geometric variation is permitted when the produced feature is at LMC and has perfect form.

5.9.5.2 Explanation of the Axis Method. Where an orientation or position tolerance is applied on a zero tolerance on an MMC basis, the feature's axis, center plane, or center point shall not violate the tolerance zone. No tolerance is allowed if the feature is produced at its MMC limit of size. Where the size of the unrelated AME of the feature departs from MMC, the tolerance zone increases. The increase in the tolerance zone is equal to the difference between the specified MMC limit of size and the unrelated AME size. The permissible variation is maximum when the unrelated AME of the feature is at LMC, unless a maximum ("MAX") is specified in the feature control frame. See [Figures 9-14](#) and [9-15](#).

5.9.6 Effect of LMC

When a geometric tolerance is applied on an LMC basis, the allowable variation is dependent on the specified geometric tolerance and the departure of the considered feature from the LMC size. The specified tolerance is only applicable when the produced feature is at the LMC limit of size. Additional tolerance is available if the produced feature departs from LMC. There are two methods for determining the amount of additional tolerance permitted. They are the surface method and the axis method. See [para. 5.9.2](#) regarding risks associated with the axis method.

5.9.6.1 Explanation of the Surface Method. When a geometric tolerance is applied on an LMC basis, the feature's surface shall not violate the VC boundary. While maintaining the specified size limits of the feature, no element of the surface shall violate the VC boundary. When a feature of size departs from LMC, additional geometric variation is permitted. The maximum geometric variation is permitted when the produced feature is at MMC.

NOTE: When a geometric tolerance applied at LMC results in a negative VC (e.g., when a 2.0–2.5 external feature of size has a position tolerance of 3.0, the VC is –1.0), the surface interpretation does not apply.

5.9.6.2 Explanation of the Axis Method. When an orientation or position tolerance is applied on an LMC basis, the feature's axis, center plane, or center point shall not violate the tolerance zone. The tolerance available is the specified value if the unrelated actual minimum material envelope is at the LMC limit of size. When the size of the unrelated actual minimum material envelope of the feature departs from LMC, the tolerance zone increases. The increase in the tolerance zone is equal to the difference between the specified LMC limit of size and the unrelated actual minimum material envelope size. The resulting tolerance zone is equal to the stated geometric tolerance plus the additional tolerance. See [Figures 10-15](#)

and 10-17. The total permissible variation for the specified geometric characteristic is maximum when the unrelated actual minimum material envelope of the feature is at MMC, unless a maximum (“MAX”) is specified in the feature control frame.

5.9.7 Effect of Zero Tolerance at LMC

When a feature of size has a geometric tolerance applied on an LMC basis and the function of the toleranced feature allows, the entire combined effects of size tolerance and geometric tolerance may be assigned as a size tolerance with the geometric tolerance of zero at LMC applied. Where a zero geometric tolerance is applied on an LMC basis, the allowable variation is entirely dependent on the departure of the produced feature from LMC. Geometric tolerance is only available if the produced feature is not at the LMC limit of size. There are two methods for determining the amount of tolerance permitted. They are the surface method and the axis method. See [para. 5.9.2](#) regarding risks associated with the axis method.

5.9.7.1 Explanation of the Surface Method. When a geometric tolerance is applied on a zero tolerance on an LMC basis, the feature’s surface shall not violate the VC boundary that is equal to the LMC size. The tolerance available is zero if the produced feature is at the LMC limit of size. When the feature of size departs from LMC, additional geometric variation is permitted. The maximum geometric variation is permitted when the produced feature is at MMC and has perfect form.

5.9.7.2 Explanation of the Axis Method. When an orientation or position tolerance is applied on a zero tolerance on an LMC basis, the feature’s axis, center plane, or center point shall not violate the tolerance zone. No tolerance is allowed if the feature is produced at its LMC limit of size. When the size of the unrelated actual minimum material envelope of the considered feature departs from LMC, the tolerance zone increases. The increase in the tolerance zone is equal to the difference between the specified LMC limit of size and the unrelated actual minimum material envelope size. See [Figure 10-15](#). The total permissible variation for the specified geometric characteristic is maximum when the unrelated actual minimum material envelope of the feature is at MMC, unless a maximum (“MAX”) is specified in the feature control frame.

5.10 SCREW THREADS

UOS, each tolerance of orientation or position and each datum reference specified for a screw thread applies to the pitch cylinder axis. When an exception to this practice is necessary, the specific feature of the screw thread (such as “MAJOR DIA” or “MINOR DIA”) shall be stated beneath or adjacent to the feature control frame or beneath or adjacent to the datum feature symbol, as applicable. See [Figure](#)

[10-36](#). For thread features, see ASME B1.1 and ASME B1.13M.

5.11 GEARS AND SPLINES

Each tolerance of orientation or position and each datum reference specified for features other than screw threads, such as gears and splines, shall designate the specific feature of the gear or spline to which each applies (such as “MAJOR DIA,” “PITCH DIA,” or “MINOR DIA”). This information should be stated beneath the feature control frame or beneath or adjacent to the datum feature symbol, as applicable.

5.12 BOUNDARY CONDITIONS

Depending on its function, a feature of size is controlled by its size and any applicable geometric tolerances. A material condition (RFS, MMC, or LMC) may also be applicable. Consideration shall be given to the collective effects of MMC and applicable tolerances in determining the clearance between parts (fixed or floating fastener formula) and in establishing gage feature sizes. Consideration shall be given to the collective effects of LMC and applicable tolerances in determining guaranteed area of contact, thin wall conservation, and alignment hole location in establishing gage feature sizes. Consideration shall be given to the collective effects of RFS and any applicable tolerances in determining guaranteed control of the feature center point, axis, derived median line, center plane, or derived median plane. See [Figures 5-14](#) through [5-19](#).

5.13 ANGULAR SURFACES

When an angular surface is defined by a combination of a directly toleranced linear dimension and an angular dimension, the surface shall be within a tolerance zone represented by two nonparallel planes. See [Figure 5-20](#). The tolerance zone widens as the distance from the apex of the angle increases. Where a tolerance zone with parallel boundaries is desired, angularity or profile tolerance should be used. See [Figure 9-1](#) and [Sections 9](#) and [11](#).

5.14 CONICAL TAPERS

Conical tapers include the category of standard machine tapers used throughout the tooling industry, classified as American Standard Self-Holding and Steep Taper series. See ASME B5.10. American Standard machine tapers are usually dimensioned and toleranced by specifying the taper name and number. See [Figure 5-21](#), illustration (b). The diameter at the gage line and the length may also be specified. The taper, in inches per foot, and the diameter of the small end may be shown as reference. A conical taper may also be specified by one of the following methods:

- (a) a basic taper and a basic diameter (see Figure 5-22)
- (b) a size tolerance combined with a profile of a surface tolerance applied to the taper (see para. 11.4.2)
- (c) a toleranced diameter at both ends of a taper and a toleranced length [see Figure 5-21, illustration (a)]

NOTE: The method described in (c) above is applicable for noncritical tapers, such as the transition between diameters of a shaft.

- (d) a composite profile tolerance

Conical taper is the ratio of the difference in the diameters of two sections (perpendicular to the axis) of a cone to the distance between these sections.

Thus, taper = $(D - d)/L$ in the following diagram:

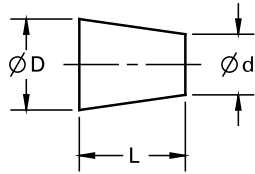

The symbol for a conical taper is shown in Figure 5-22.

5.15 FLAT TAPERS

A flat taper may be specified by a toleranced slope and a toleranced height at one end. See Figure 5-23. Slope may be specified as the inclination of a surface expressed as a ratio of the difference in the heights at each end (above and at right angles to a base line) to the distance between those heights.

Thus, slope = $(H - h)/L$ in the following diagram:

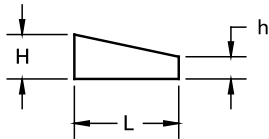

The symbol for slope is shown in Figure 5-23.

5.16 RADIUS

When a radius is specified, the details in paras. 5.16.1 and 5.16.2 shall apply.

5.16.1 Directly Toleranced Radius

When a radius symbol R is specified, a tolerance zone bounded by two arcs is created (the minimum and maximum radii). The part surface shall be within this zone. When the center of the radius is located via dimension(s), the arcs are concentric. When the center of the radius is not located (tangent located), the arcs are tangent to the adjacent surfaces and create a crescent-shaped tolerance zone. See Figure 5-24.

5.16.2 Controlled Radius Tolerance

When a controlled radius is specified, a tolerance zone bounded by two arcs is created (the minimum and maximum radii). The part surface shall be within this tolerance zone and shall be a fair curve without reversals. Additionally, radii taken at all points on the part contour shall be neither smaller than the specified minimum limit nor larger than the maximum limit. See Figure 5-25. When the center of the radius is located via dimension(s), the arcs are concentric. When the center of the radius is not located (tangent located), the arcs are tangent to the adjacent surfaces and create a crescent-shaped tolerance zone.

NOTE: It is recommended that the controlled radius only be used if its meaning is clarified by a general note, a company or industry standard, or another engineering specification. This clarification should define the limits of allowable imperfections, and should be referenced on the drawing, annotated model, or elsewhere in the data set.

5.17 TANGENT PLANE

When it is desired to control a tangent plane established by the contacting points of a surface, the tangent plane symbol shall be added in the feature control frame after the stated tolerance. See Figures 9-17 and 9-18. Where irregularities on the surface cause the tangent plane to be unstable (i.e., it rocks) when brought into contact with the corresponding toleranced feature, see para. 7.11.2 and ASME Y14.5.1M.

5.18 STATISTICAL TOLERANCING

When it is the choice of the design activity to use statistical tolerancing, it may be indicated in the following manner. See Figures 5-26 through 5-28.

(a) A note such as the following shall be placed on the drawing: **FEATURES IDENTIFIED WITH THE STATISTICALLY TOLERANCED SYMBOL SHALL BE PRODUCED WITH STATISTICAL PROCESS CONTROLS.** See Figure 5-26.

(b) When it is necessary to designate both the statistical limits and the arithmetic limits where the dimension has the possibility of being produced without statistical process control (SPC), a note such as the following shall be placed on the drawing: **FEATURES IDENTIFIED WITH THE STATISTICALLY TOLERANCED SYMBOL SHALL BE PRODUCED WITH STATISTICAL PROCESS CONTROLS, OR TO THE MORE RESTRICTIVE ARITHMETIC LIMITS.** See Figure 5-27.

CAUTION: When using the “statistical tolerancing” symbol, the necessary statistical indices should be specified.

Figure 5-1 Limit Dimensioning

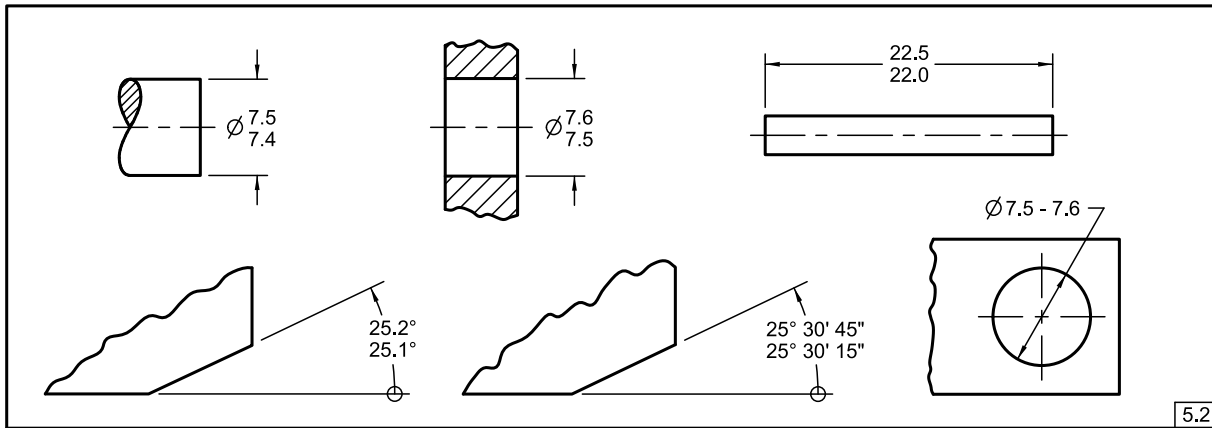

Figure 5-2 Plus and Minus Tolerancing

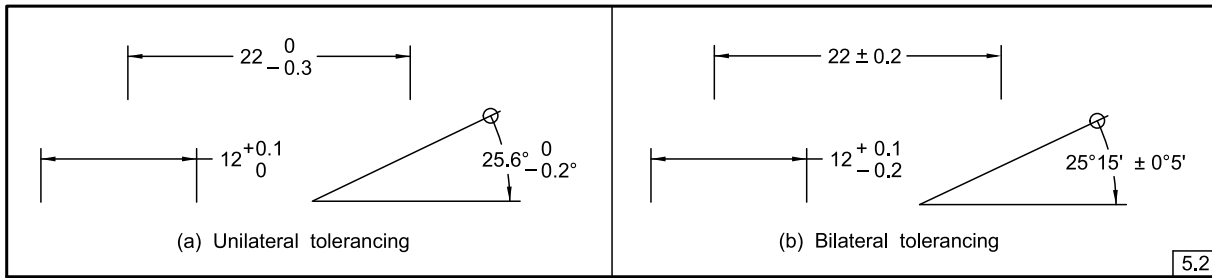

Figure 5-3 Indicating Symbols for Metric Limits and Fits

(a) 29.980 29.959 (30 f7)	(b) 30 f7 $\left(\begin{matrix} 29.980 \\ 29.959 \end{matrix} \right)$	(c) 30 f7	$\begin{matrix} 6.3.8 \\ 5.2.1 \end{matrix}$
------------------------------	---	-----------	--

Figure 5-4 Tolerance Accumulation: One Datum Reference Frame

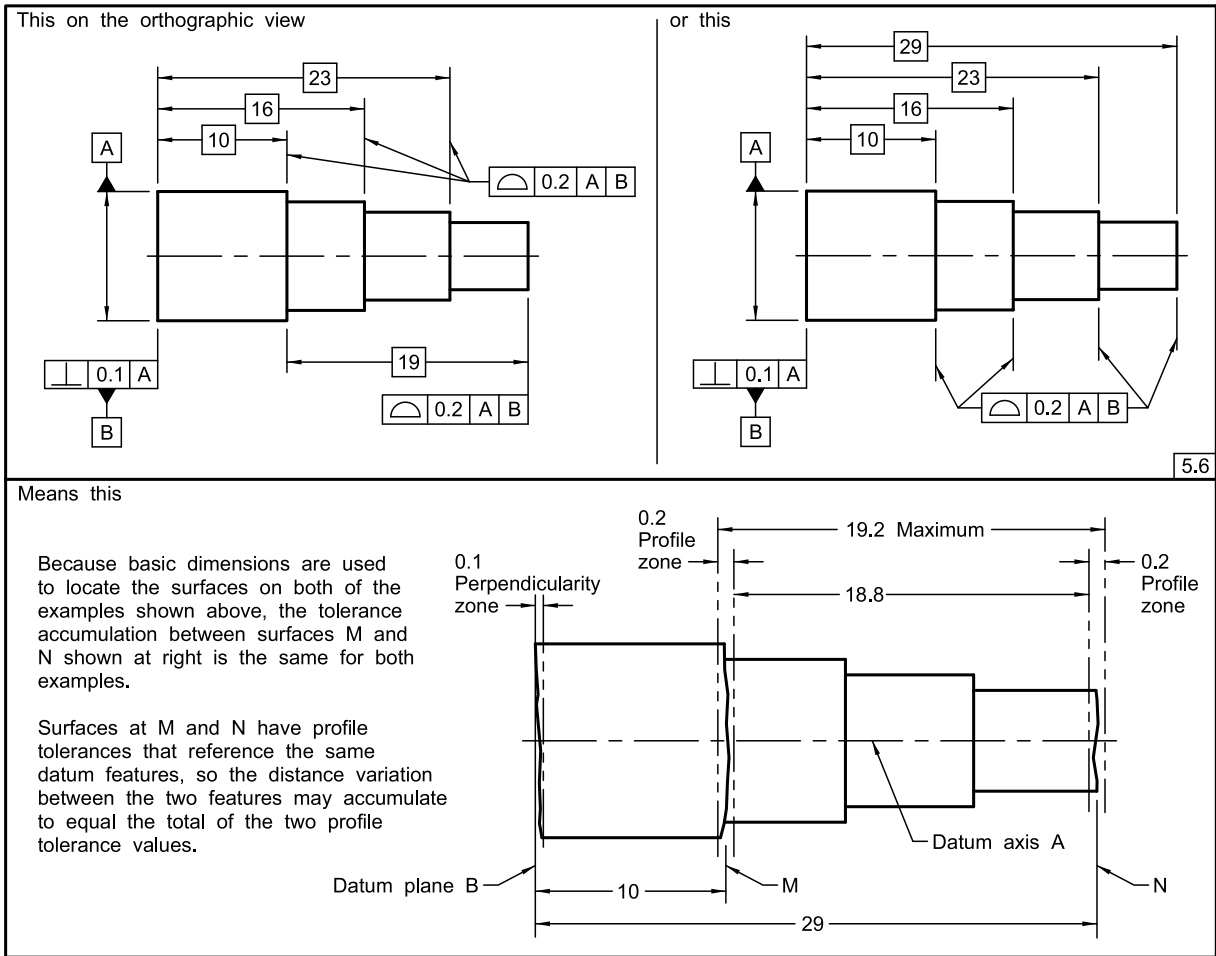

Figure 5-5 Tolerance Accumulation: Multiple Datum Reference Frames

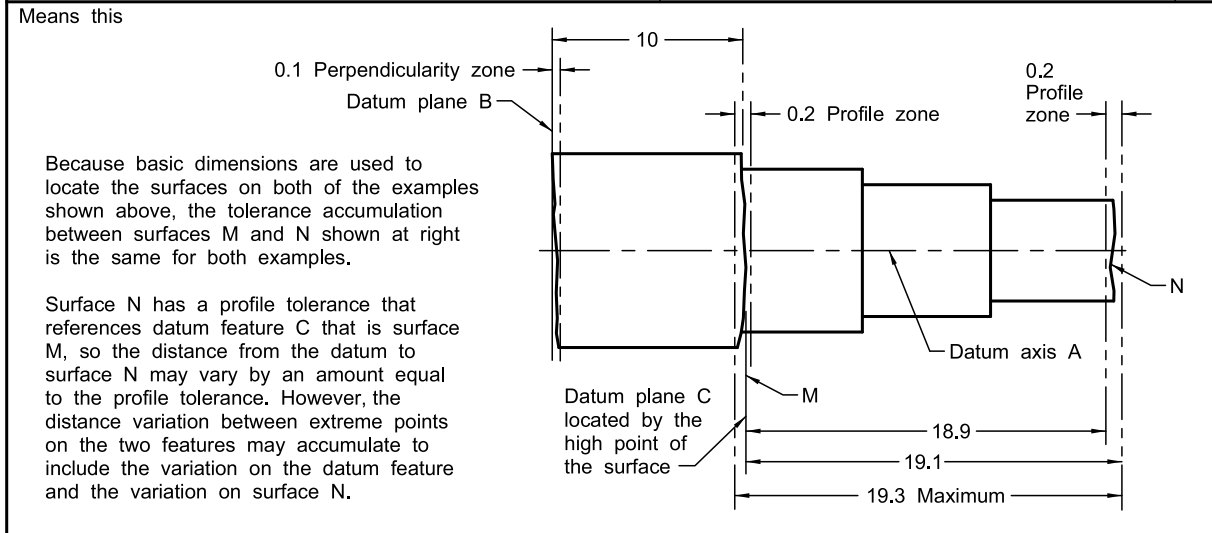
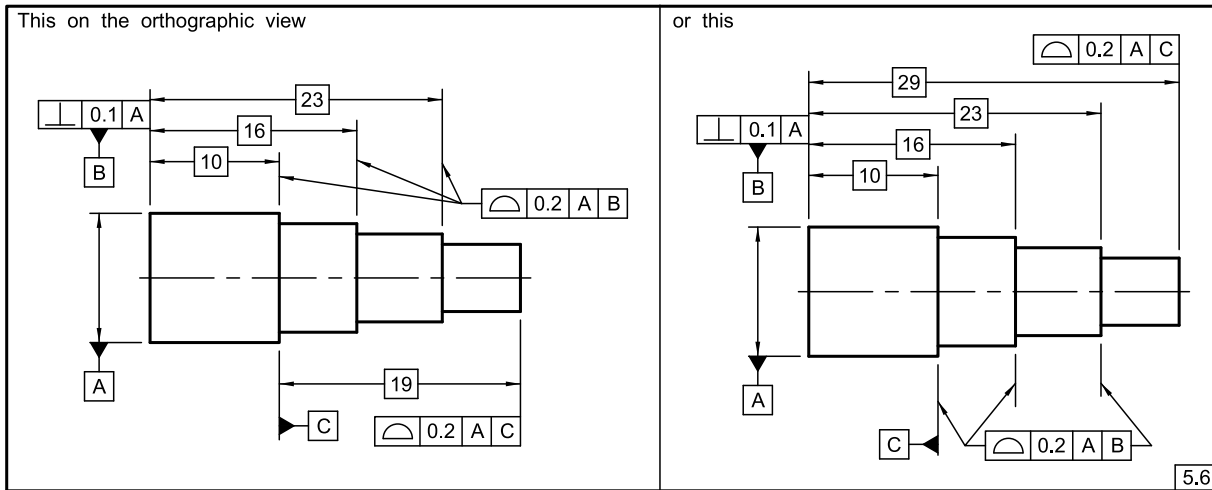

Figure 5-6 Relating Dimensional Limits to an Origin

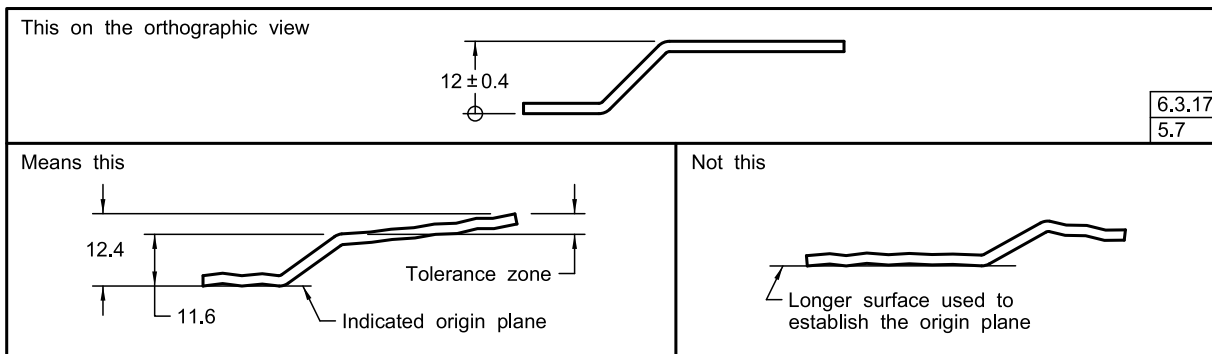

Figure 5-7 Extreme Variations of Form Allowed by a Size Tolerance

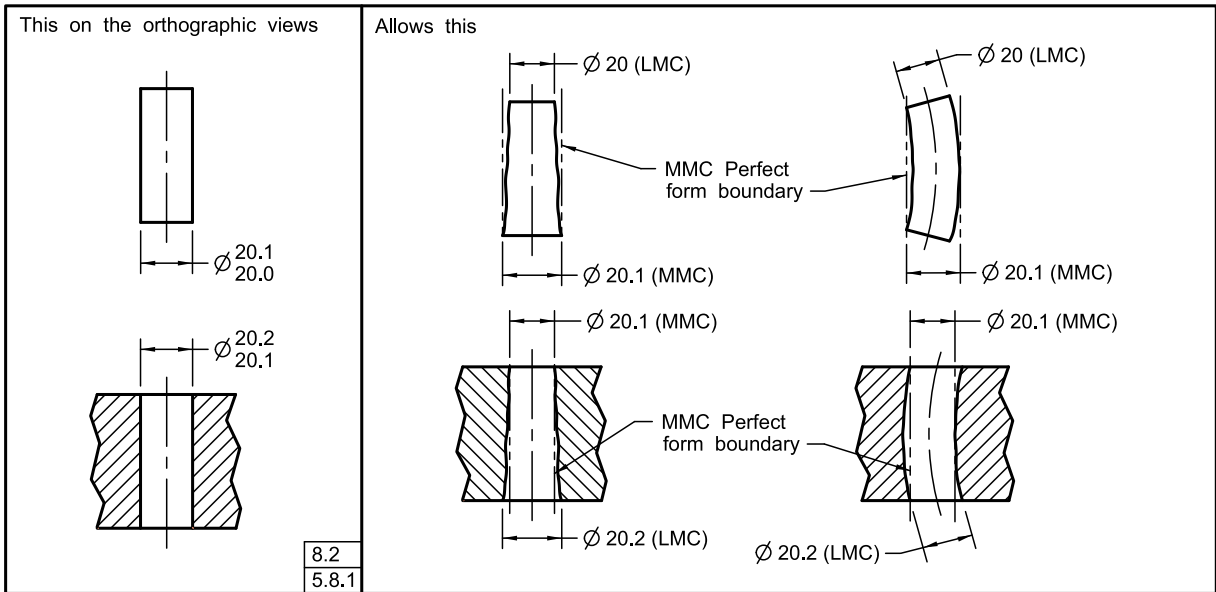

Figure 5-8 Extreme Variations of Form Allowed by a Geometric Tolerance — Perfect Form at LMC

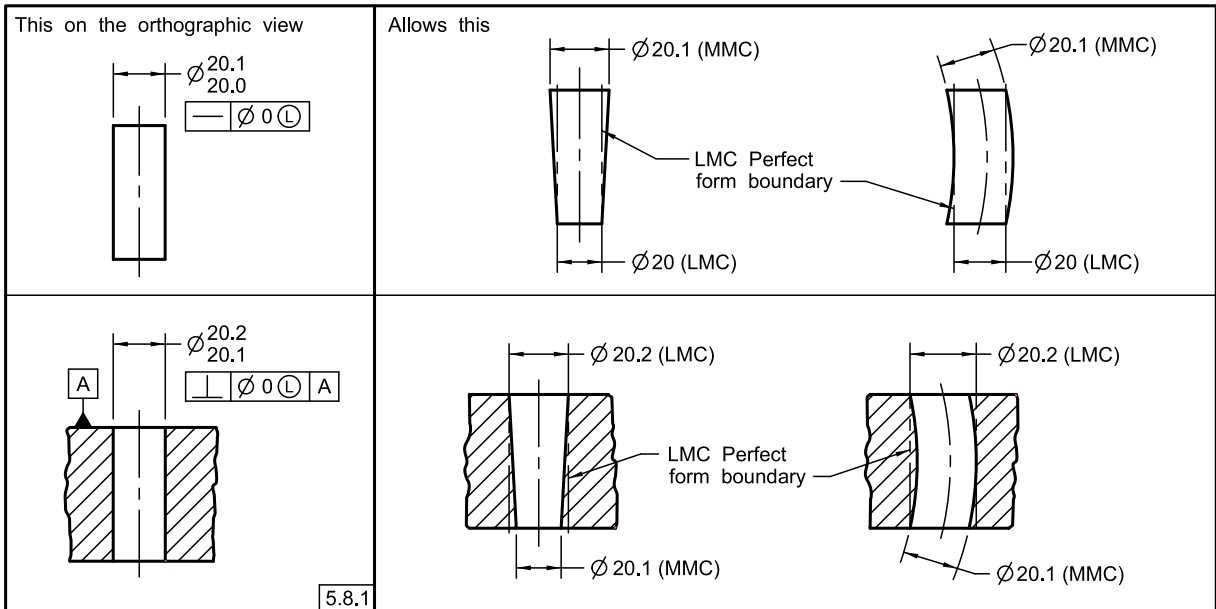

Figure 5-9 Size Meaning

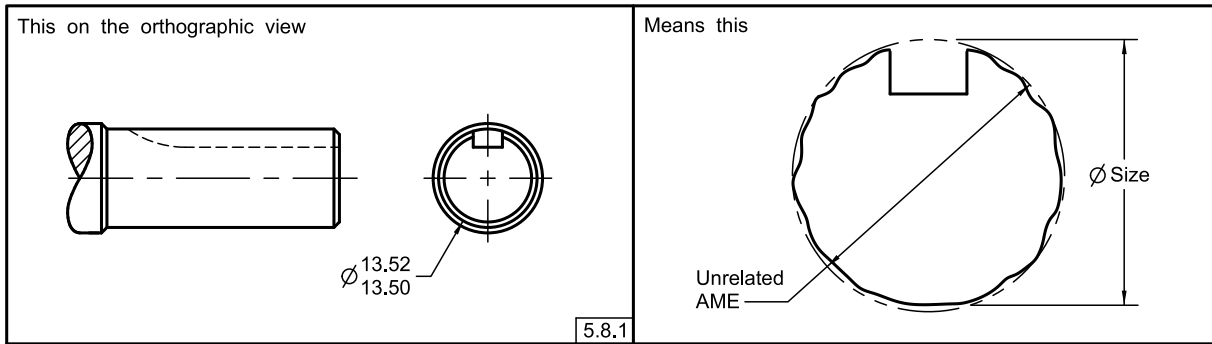

Figure 5-10 Independency and Flatness Application

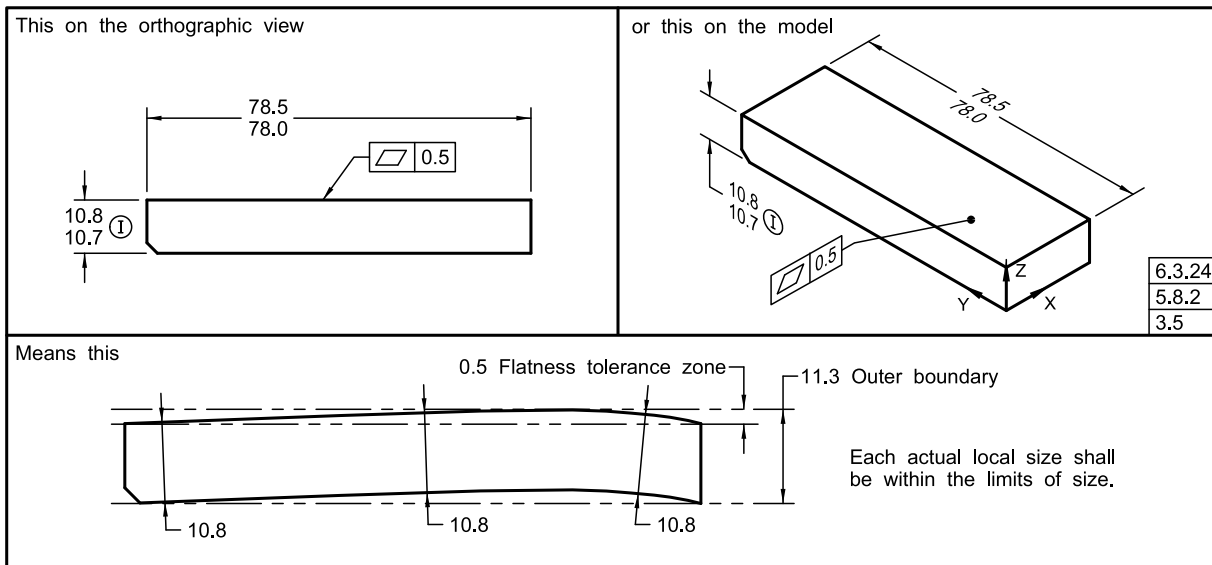

Figure 5-11 Continuous Feature, External Cylindrical

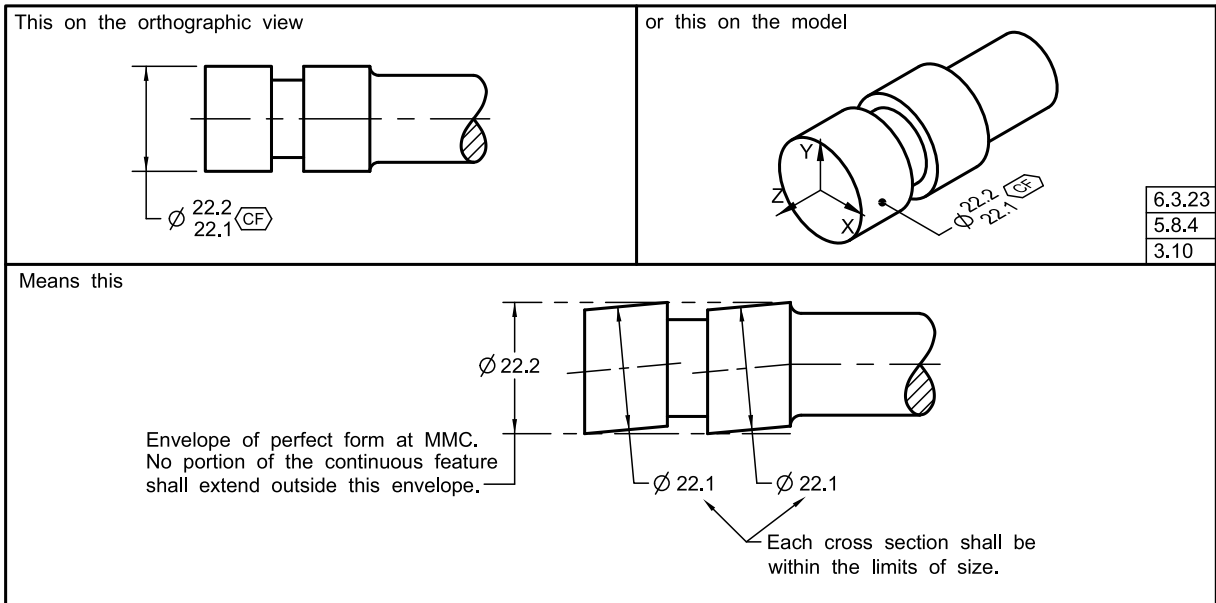

Figure 5-12 Continuous Feature, Internal Cylindrical

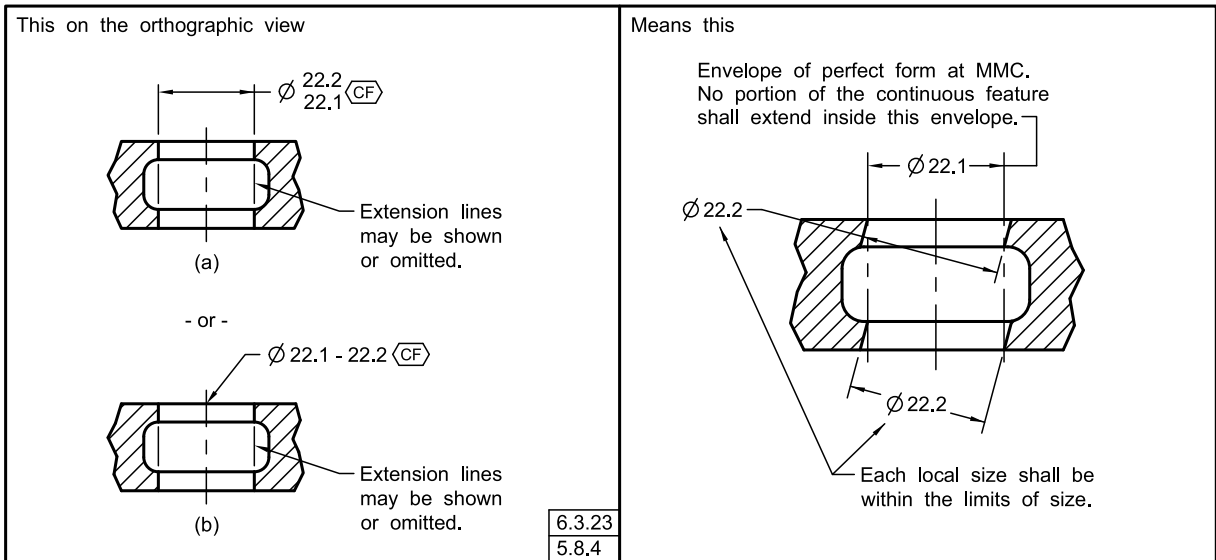

Figure 5-13 Continuous Feature, External Width

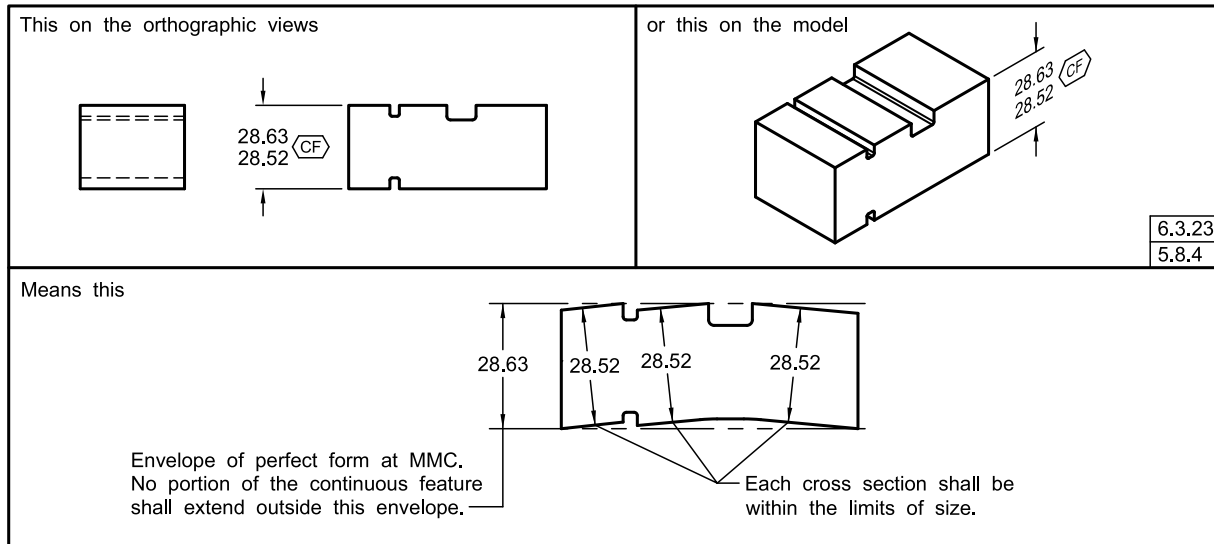

Figure 5-14 Virtual and Resultant Condition Boundaries Using the MMC Concept — Internal Feature

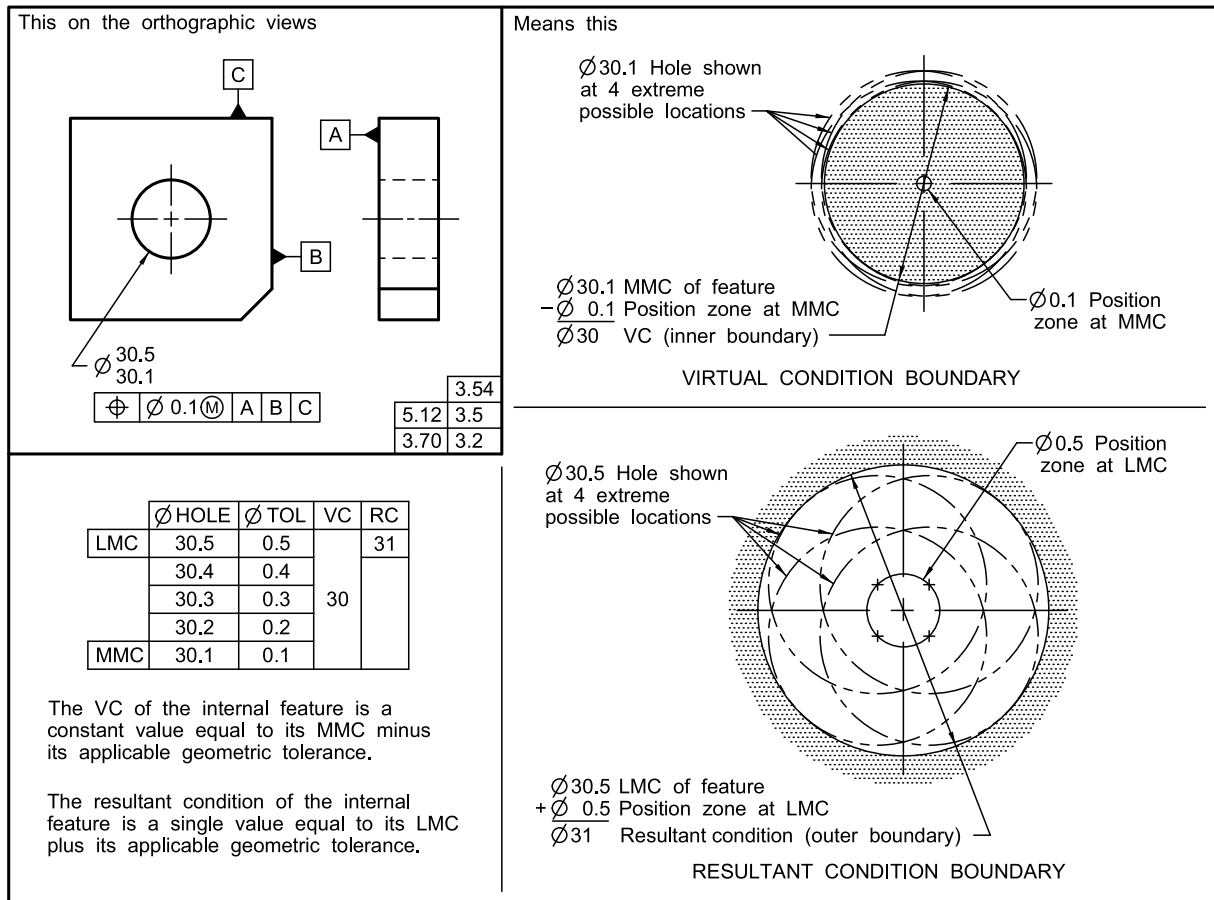

Figure 5-15 Virtual and Resultant Condition Boundaries Using the LMC Concept — Internal Feature

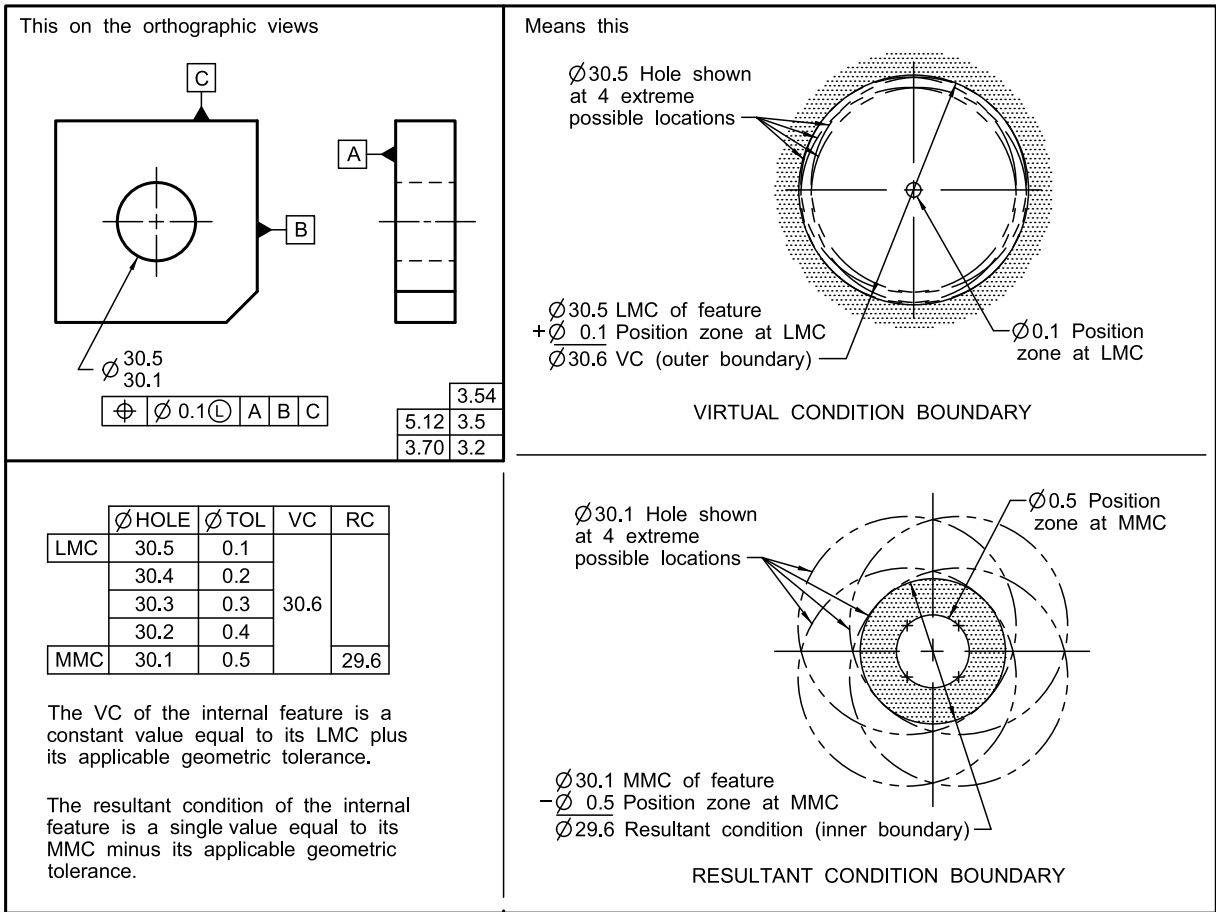

Figure 5-16 Inner and Outer Boundaries Using the RFS Concept — Internal Feature

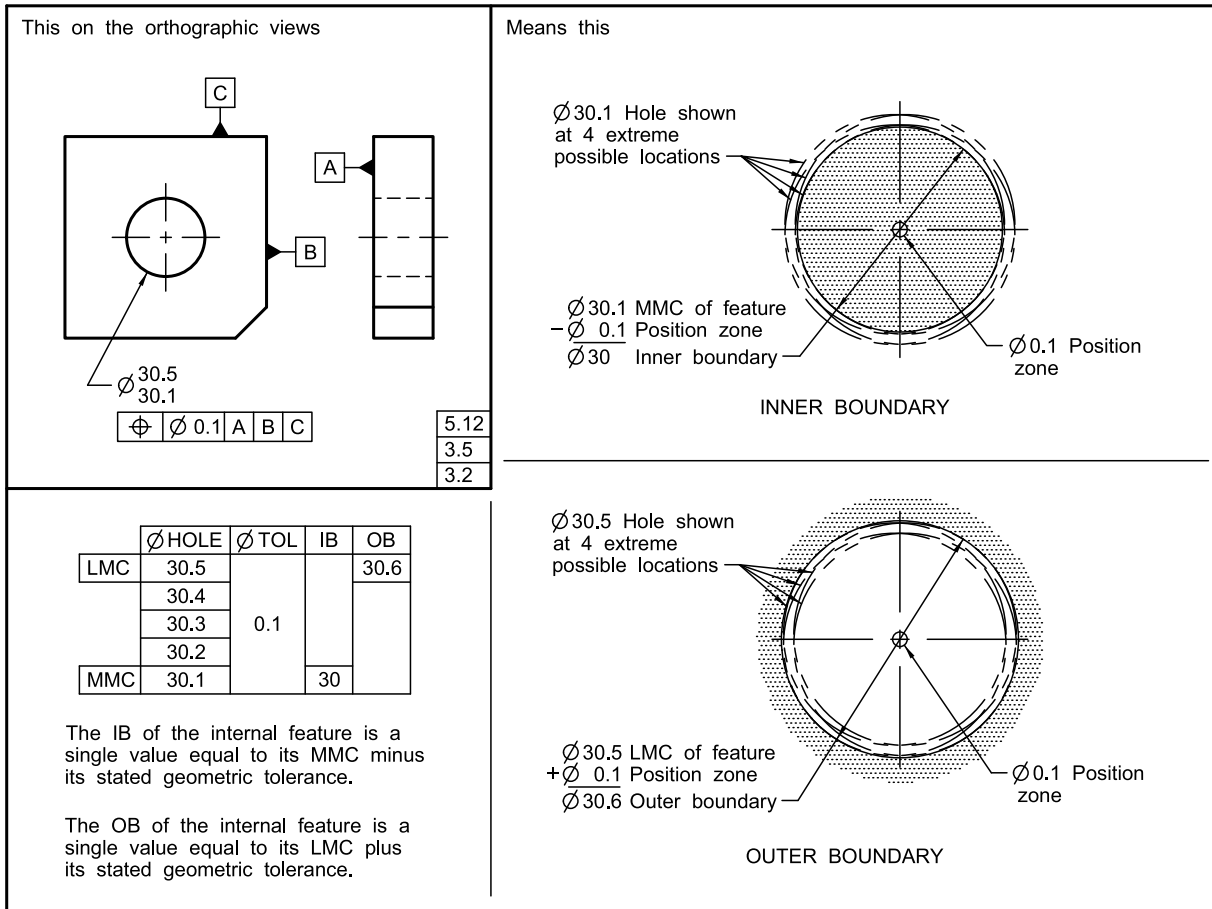

Figure 5-17 Virtual and Resultant Condition Boundaries Using the MMC Concept — External Feature

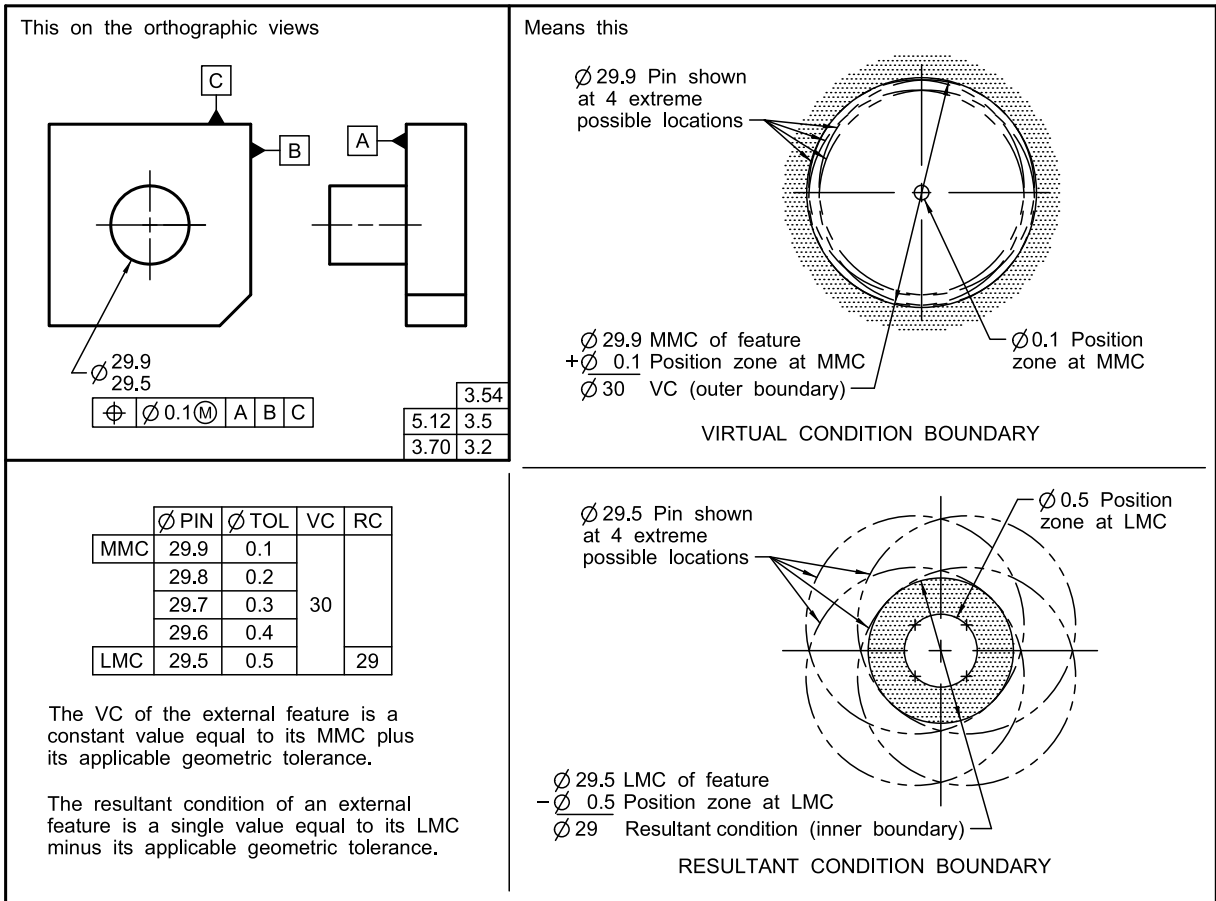

Figure 5-18 Virtual and Resultant Condition Boundaries Using the LMC Concept — External Feature

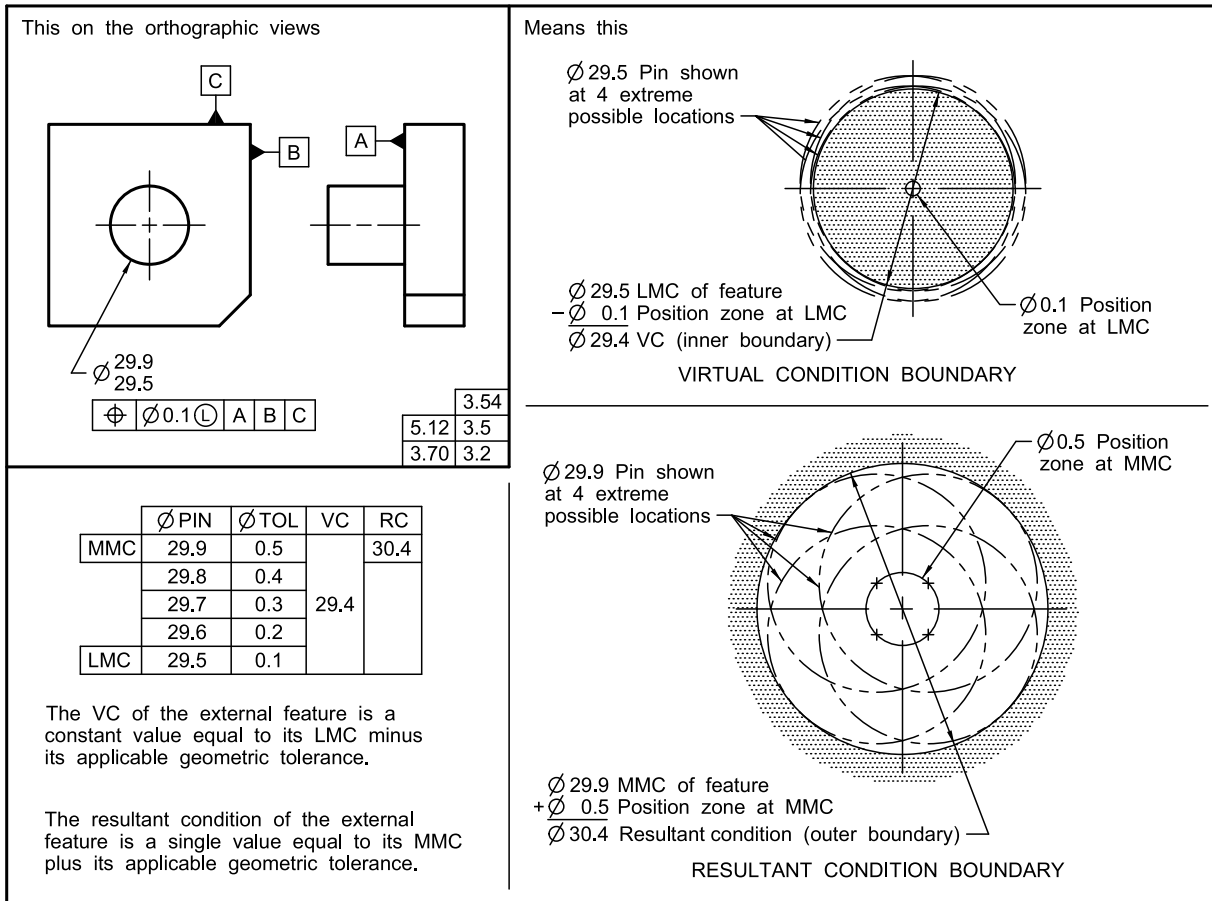

Figure 5-19 Inner and Outer Condition Boundaries Using the RFS Concept — External Feature

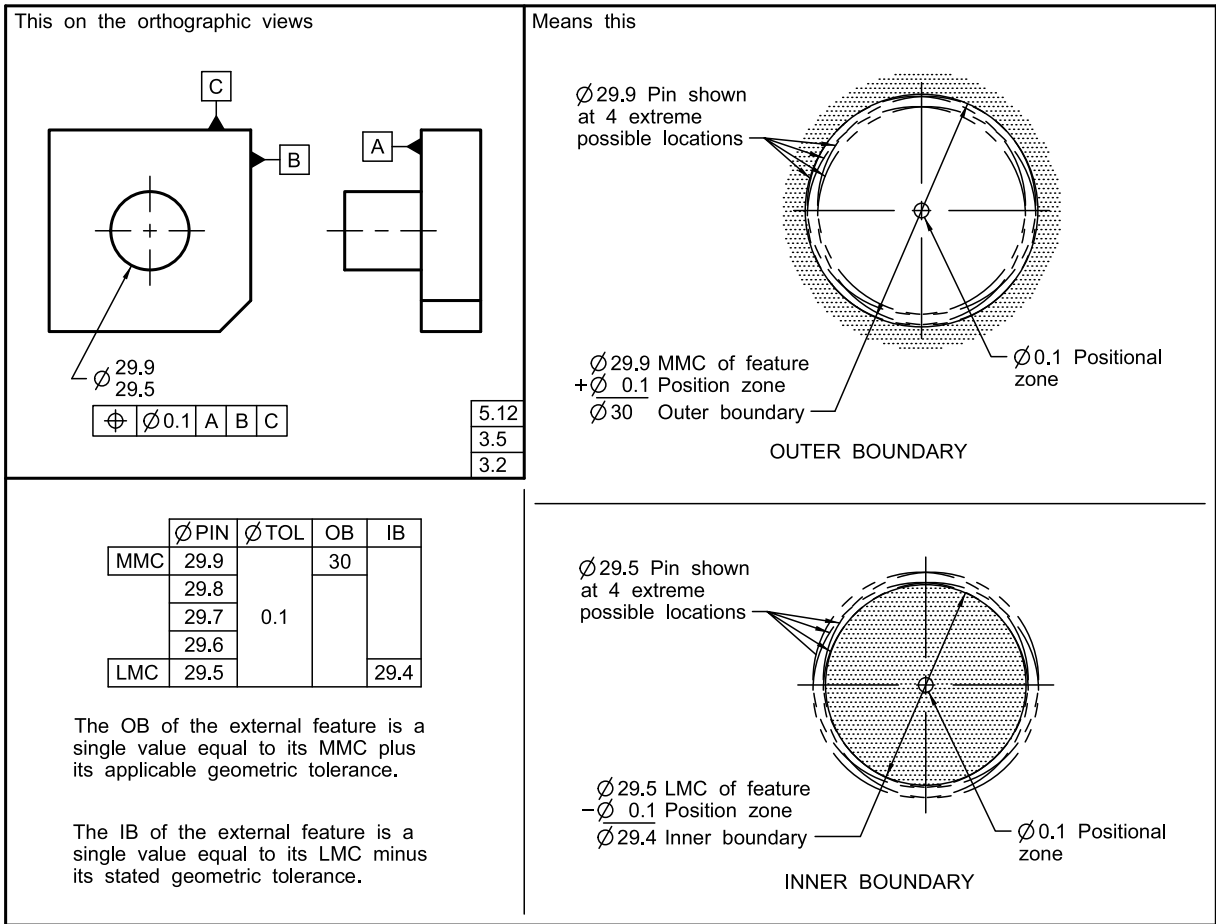

Figure 5-20 Tolerancing an Angular Surface Using a Combination of Linear and Angular Dimensions

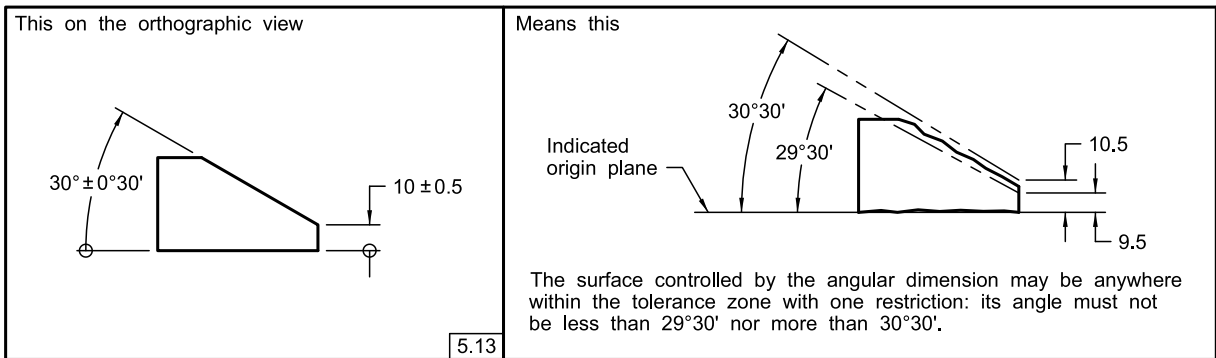

Figure 5-21 Specifying Tapers

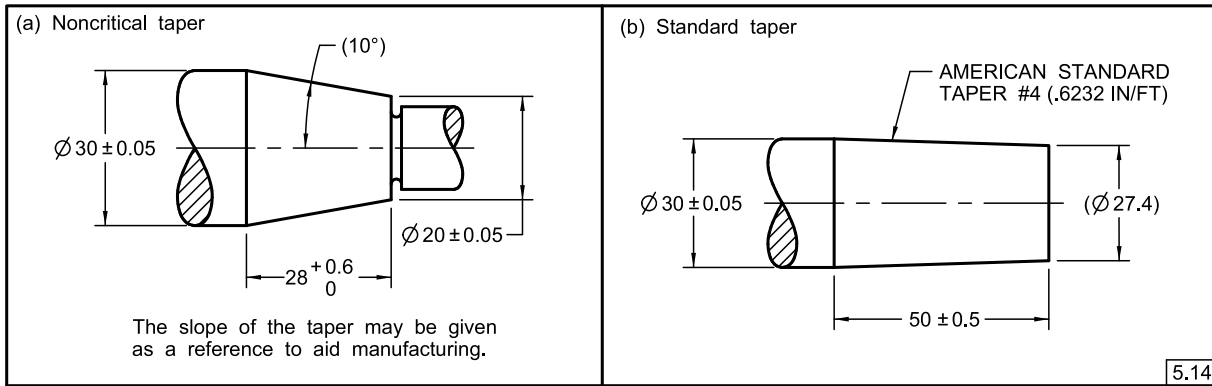

Figure 5-22 Specifying a Basic Taper and a Basic Diameter

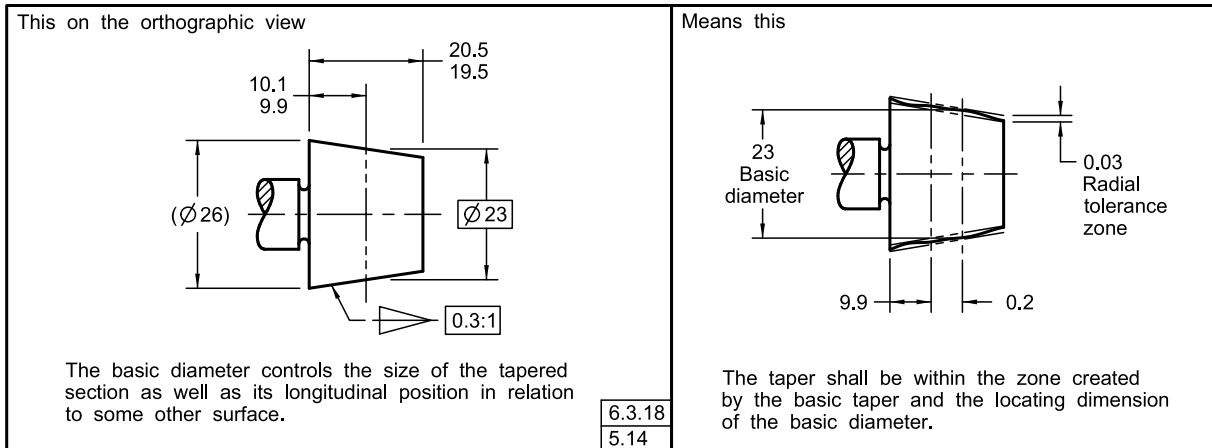

Figure 5-23 Specifying a Flat Taper

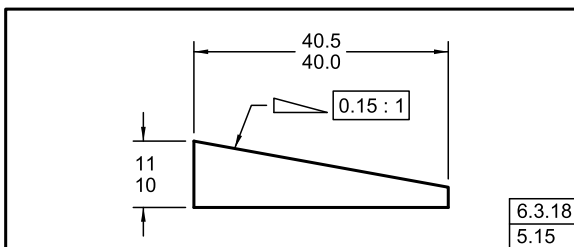

Figure 5-24 Specifying a Radius

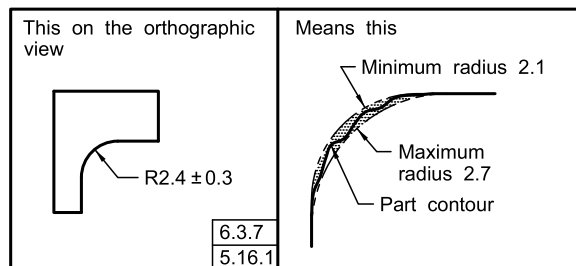

Figure 5-25 Specifying a Controlled Radius

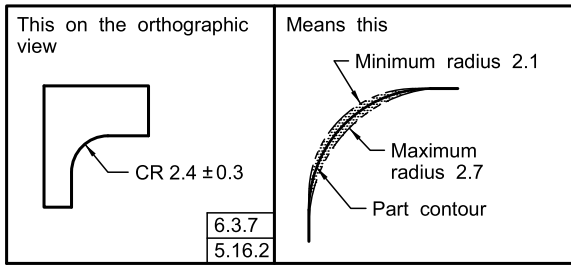

Figure 5-26 Statistical Tolerancing

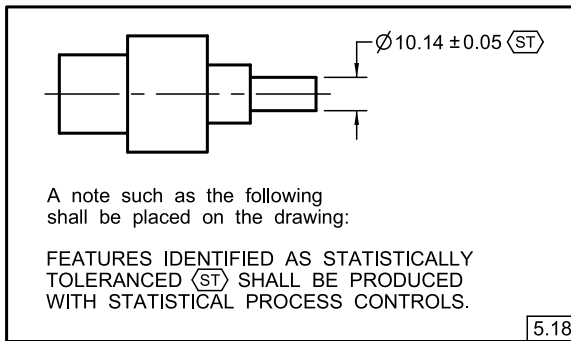

Figure 5-27 Statistical Tolerancing With Arithmetic Limits

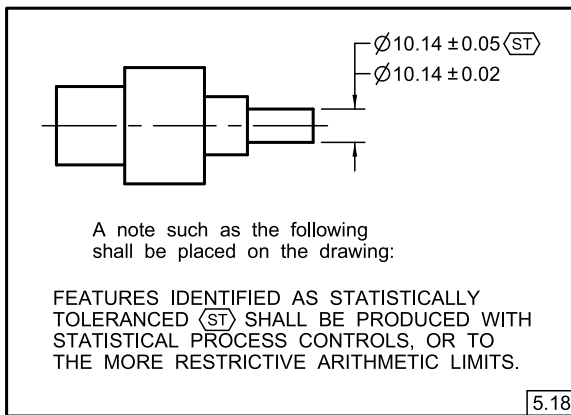
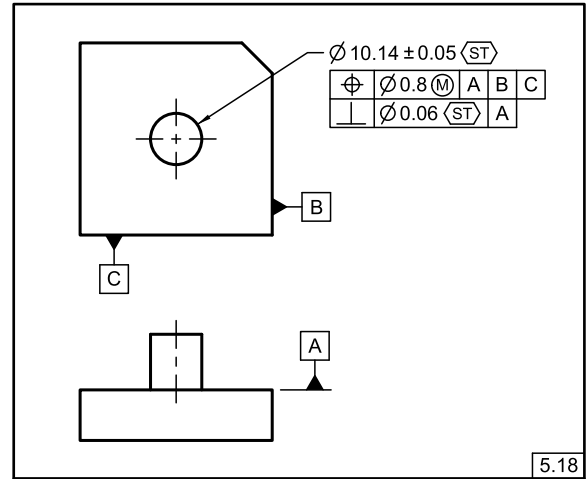

Figure 5-28 Statistical Tolerancing With Geometric Controls



Section 6 Symbology

6.1 GENERAL

This Section establishes the symbols, notes, and other dimensional requirements used in engineering data. It also establishes how the symbols are indicated in engineering data.

6.2 USE OF NOTES TO SUPPLEMENT SYMBOLS

Situations may arise in which the desired geometric requirements cannot be completely conveyed by symbology. In such cases, a note should be used to describe the requirement, either separately or to supplement a geometric symbol. See [Figures 9-16](#) and [10-54](#).

6.3 SYMBOL CONSTRUCTION

Information related to the construction, form, and proportion of individual symbols described herein is contained in [Nonmandatory Appendix C](#). Symbols shall be of sufficient clarity to meet the legibility and reproducibility requirements of ASME Y14.2.

6.3.1 Geometric Characteristic Symbols

The symbolic means of indicating geometric characteristics are shown in [Figure 6-1](#).

6.3.2 Datum Feature Symbol

The symbolic means of indicating a datum feature consists of an uppercase letter enclosed in a square or rectangular frame and a leader line extending from the frame to the feature, terminating with a triangle. The triangle may be filled or not filled. See [Figure 6-2](#). Letters of the alphabet (except I, O, and Q) shall be used as datum feature identifying letters. Each datum feature of a part requiring identification shall be assigned a different letter. When datum features requiring identification on a drawing are so numerous as to exhaust the single-alpha series, the double-alpha series (AA through AZ, BA through BZ, etc.) shall be used and enclosed in a rectangular frame. Where the same datum feature symbol is repeated to identify the same feature in other locations of a drawing, it need not be identified as reference. The triangle of the datum feature symbol may be applied to the feature surface, surface outline, extension line, dimension line, or feature control frame as described in [paras. 6.3.2.1](#)

and [6.3.2.2](#). The datum feature symbol shall not be applied to center lines, center planes, or axes.

6.3.2.1 Datum Feature Symbol Application in Orthographic Views.

The datum feature symbol may be

- (a) placed on the outline of a feature surface.
- (b) placed on an extension line of the feature outline clearly separated from the dimension line, when the datum feature is the surface itself.

- (c) placed on a leader line directed to the surface. When the datum feature is hidden, the leader line may be shown as a dashed line. See [Figure 6-3](#).

- (d) placed on the dimension line or an extension of the dimension line of a feature of size when the datum is an axis or center plane. If there is insufficient space for the two arrows, one arrow may be replaced by the datum feature triangle. See [Figure 6-4](#), illustrations (a) through (c), (f), and (h); [Figure 7-40](#); and [Figure 7-42](#), illustrations (c) and (d).

- (e) placed on the outline of a cylindrical feature surface or an extension line of the feature outline, separated from the size dimension, when the datum is an axis. For curved features, the triangle may be tangent to the feature. See [Figure 6-4](#), illustrations (e) and (g).

- (f) placed on the horizontal portion of a dimension leader line for the size dimension. See [Figure 6-4](#), illustration (d); [Figures 7-32](#) and [7-33](#); and [Figure 7-42](#), illustrations (a) and (b).

- (g) placed above or below and attached to the feature control frame. See [para. 6.4.6](#) and [Figures 6-5](#) and [6-28](#).

- (h) placed on a chain line that indicates a partial datum feature. See [Figure 7-28](#).

- (i) attached to a profile tolerance that is applicable to more than one surface, thus identifying the surfaces as acting together to establish one datum. See [Figure 6-6](#).

6.3.2.2 Datum Feature Symbol Application on Models.

See ASME Y14.41 for additional information regarding datum feature symbol application on models. The datum feature symbol may be

- (a) placed on the feature surface.

- (b) placed on a leader line directed to the surface. See [Figure 6-3](#).

- (c) placed on the dimension line or an extension of the dimension line of a feature of size when the datum is an axis or center plane. If there is insufficient space for the two arrows, one arrow may be replaced by the datum

feature triangle. See [Figure 6-4](#), illustration (l); [Figure 7-40](#); and [Figure 7-42](#), illustrations (c) and (d).

(d) placed on the outline of a cylindrical feature surface or an extension line of the feature outline, separated from the size dimension, when the datum is an axis. For curved features, the triangle may be tangent to the feature. See [Figure 6-4](#), illustrations (i) and (j).

(e) placed on the horizontal portion of a dimension leader line for the size dimension. See [Figure 6-4](#), illustration (k) and [Figure 7-42](#), illustrations (a) and (b).

(f) placed above or below and attached to the feature control frame. See [para. 6.4.6](#) and [Figures 6-5](#) and [6-28](#).

(g) attached by leader or placed on an indicated partial datum feature. See [Figure 7-28](#).

(h) attached to a profile tolerance that is applicable to more than one surface, thus identifying the surfaces as acting together to establish one datum.

6.3.3 Symbology for Datum Targets

6.3.3.1 Datum Target Symbol. The symbolic means of indicating a datum target shall be a circle divided horizontally into halves. The lower half contains a letter identifying the associated datum, followed by the target number assigned sequentially, starting with 1 for each datum. See [Figure 6-7](#). The symbol should be placed outside the part outline. A radial line attached to the symbol shall be directed to a target point, target line, target area, or other geometry, as applicable. In orthographic views, a solid radial line indicates that the datum target is on the near (visible) view of the surface, and a dashed radial line indicates that the datum target is on the far (hidden) surface. See [Figure 7-58](#). In a model, the leader is always solid. Where datum target symbols are used, the datum feature may also be identified with the datum feature symbol. Where the datum feature symbol is used in combination with datum targets, the letter and numbers (separated by commas) identifying the associated datum targets shall be shown near the datum feature symbol. See [Figure 7-64](#).

6.3.3.2 Datum Target Point Symbol. A datum target point shall be indicated by the target point symbol. Where shown in orthographic views, the targets shall be dimensionally located in a direct view of the surface, or, where there is no direct view, the point location shall be dimensioned on two adjacent views. See [Figures 6-8](#) and [7-60](#). In a model, the location shall be defined either by the application of dimensions or by the model geometry.

6.3.3.3 Datum Target Line Symbol. Where shown in orthographic views, a datum target line shall be indicated by the datum target point symbol on an edge view of the surface, a phantom line on the direct view, or both with controlling dimensions added. Where shown in a model, the datum target line is represented by a phantom line, and the location shall be defined either by the application of

dimensions or by the model geometry. See [Figures 6-9](#) and [7-60](#).

6.3.3.4 Datum Target Area Symbol. Where a datum target area is required, a target area of the desired size and shape shall be specified. In an orthographic view, the datum target area shall be indicated by section lines inside a phantom outline of the desired shape, with controlling dimensions added when the target area is within a larger area and is large enough to be shown. The basic dimension of size and shape of the area shall be specified by direct application of dimensions, entered in the upper half of the datum target symbol, defined in a note, or defined by the model. See [Figure 6-10](#), illustration (a) and [Figure 7-63](#). If there is not sufficient space within the upper half, the size and shape of the area may be placed outside and connected by a leader line terminating with a dot inside the upper half. Target area dimensions attached by leader line are treated as basic as if placed inside the circle unless directly tolerated as allowed by [para 7.24.3](#). See [Figure 6-7](#) and [Figure 6-10](#), illustration (b). On a model, target areas are shown with supplemental geometry. See ASME Y14.41. See ASME Y14.43 for datum target tolerances.

6.3.4 Basic Dimension Symbol

The symbolic means of indicating a basic dimension shall be to enclose the dimension value in a rectangle as shown in [Figure 6-11](#).

6.3.5 Material Condition/Boundary Symbols

The symbolic means of indicating “at MMC” or “at MMB” and “at LMC” or “at LMB” shall be as shown in [Figures 6-12](#) and [7-4](#).

6.3.6 Projected Tolerance Zone Symbol

The symbolic means of indicating a projected tolerance zone shall be as shown in [Figures 6-12](#), [10-22](#), and [10-23](#).

6.3.7 Diameter and Radius Symbols

The symbols used to indicate diameter, spherical diameter, radius, spherical radius, and controlled radius shall be as shown in [Figures 5-24](#), [5-25](#), and [6-12](#). These symbols shall precede the value of a dimension or tolerance given as a diameter or radius, as applicable. The symbol and the value shall not be separated by a space.

6.3.8 Reference Symbol

The symbolic means of indicating a dimension or other dimensional data as reference shall be to enclose the dimension (or dimensional data) within parentheses. See [Figures 5-3](#) and [6-12](#). In written notes, parentheses retain their grammatical interpretation UOS. When it is necessary to define dimensions or dimensional data as

reference in a note, the term “REFERENCE” or the abbreviation “REF” shall be used.

6.3.9 Arc Length Symbol

The symbolic means of indicating that a dimension is an arc length measured on a curved outline shall be as shown in [Figure 6-12](#). The symbol shall be placed above the dimension and applies to the surface nearest the dimension.

6.3.10 Statistical Tolerancing Symbol

The symbolic means of indicating that a tolerance is based on statistical tolerancing shall be as shown in [Figure 6-12](#). If the tolerance is a statistical geometric tolerance, the symbol shall be placed in the feature control frame following the stated tolerance and any modifier. See [Figure 6-13](#). If the tolerance is a statistical size tolerance, the symbol shall be placed adjacent to the size dimension. See [Figure 6-14](#).

6.3.11 “Between” Symbol

The symbolic means of indicating that a tolerance or other specification applies across multiple features or to a limited segment of a feature between designated extremities shall be as shown in [Figures 6-12, 6-15, 11-8, and 11-9](#). The leader from the feature control frame shall be directed to the portion of the feature to which that tolerance applies. In [Figure 6-15](#), for example, the tolerance applies only between “G” and “H.” “G” and “H” may be points, lines, or features.

6.3.12 Counterbore Symbol

The symbolic means of indicating a counterbore shall be as shown in [Figures 4-35 and 6-16](#). The symbol shall precede, with no space, the dimension of the counterbore.

6.3.13 Spotface Symbol

The symbolic means of indicating a spotface shall be as shown in [Figures 4-39 and 6-16](#). The symbol shall precede, with no space, the dimension of the spotface.

6.3.14 Countersink Symbol

The symbolic means of indicating a countersink shall be as shown in [Figures 4-37 and 6-17](#). The symbol shall precede, with no space, the dimension of the countersink.

6.3.15 Depth Symbol

The symbolic means of indicating that a dimension applies to the depth of a feature shall be a depth symbol preceding the depth dimension, as shown in [Figure 6-18](#). No space is shown between the symbol and the dimension value.

6.3.16 Square Symbol

The symbolic means of indicating that a single dimension applies to a square shape shall be to precede that dimension with the square symbol, as shown in [Figures 6-12 and 6-19](#). No space is shown between the symbol and the dimension value.

6.3.17 Dimension Origin Symbol

The symbolic means of indicating that a toleranced dimension between two features originates from one of these features and not the other shall be as shown in [Figures 5-6, 6-12, and 6-20](#).

6.3.18 Taper and Slope Symbols

The symbolic means of indicating taper and slope for conical and flat tapers shall be as shown in [Figures 5-22 and 5-23](#). These symbols shall be shown with the vertical leg to the left.

6.3.19 “All Around” Symbol

For orthographic views, the symbolic means of indicating that a profile tolerance or other specification applies to surfaces all around a feature or group of features, in the view specified, shall be a circle located at the junction of the leader from the feature control frame. See [Figures 6-12, 6-21, and 11-5](#). In a model used to generate orthographic views, the “all around” symbol is used in combination with establishing associativity of the features and the feature control frame. See ASME Y14.41.

6.3.20 “Free State” Symbol

Where tolerances are defined as applicable in a restrained condition and an additional tolerance is applied in the free state as defined in [subsection 7.20](#), the symbolic means of indicating that the toleranced feature or datum feature applies in its free state is shown in [Figures 6-12 and 6-22](#). When the symbol is applied to a tolerance in the feature control frame, it shall follow the stated tolerance and any modifier. When the symbol is applied to a datum feature reference, it shall follow the datum feature reference and any modifier. See [Figures 7-50 and 7-51](#). When the symbol is applied to a directly toleranced dimension, it shall follow the dimension and tolerance.

6.3.21 Tangent Plane Symbol

The symbolic means of indicating a tangent plane shall be as shown in [Figure 6-12](#). The symbol shall be placed in the feature control frame following the stated tolerance as shown in [Figures 9-17 and 9-18](#). Also see [subsections 3.47 and 9.4](#).

6.3.22 “Unequally Disposed” Profile Symbol

The symbolic means of indicating a unilateral or unequally disposed profile tolerance is shown in [Figure 6-12](#). The symbol shall be placed in the feature control frame following the tolerance value, as shown in [Figures 11-2](#) through [11-4](#) and [para. 11.3.1.2](#).

6.3.23 “Continuous Feature” Symbol

The symbolic means for identifying two or more interrupted features or interrupted regular features of size as a single feature or feature of size is shown in [Figure 6-12](#). The “CF” symbol shall be applied to a size dimension of an interrupted regular feature of size, adjacent to a geometric tolerance for an interrupted surface, or adjacent to a datum feature symbol applied to interrupted features. When using the “CF” symbol, the extension lines between the features may be shown or omitted; however, extension lines by themselves do not indicate a CF. See [Figures 5-11](#) through [5-13](#) and [10-32](#), and [para. 5.8.4](#). The number of surfaces (n) that are included in the CF, such as “ n SURFACES,” may be added beside the “CF” symbol.

6.3.24 “Independency” Symbol

The symbolic means for indicating that perfect form of a regular feature of size at MMC or at LMC is not required is shown in [Figure 6-12](#). The symbol shall be placed near the appropriate dimension or notation. See [para. 5.8.2](#) and [Figure 5-10](#).

6.3.25 “All Over” Symbol

The symbolic means for indicating that a profile tolerance or other specification shall apply all over the three-dimensional profile of a part is shown in [Figure 6-12](#). See [Figures 6-21](#) and [11-10](#) and [para. 11.3.1.5](#).

6.3.26 Datum Translation Symbol

The symbolic means for indicating that a true geometric counterpart shall not be fixed at its basic location and shall be free to translate is shown in [Figure 6-12](#). See [Figures 7-21](#) and [7-39](#) and [para. 7.16.10](#).

6.3.27 “Movable Datum Target” Symbol

The symbolic means of indicating that a datum target shall not be fixed at its basic location and shall be free to translate is shown in [Figure 6-23](#). See [Figures 7-58](#) and [7-59](#) and [para. 7.24.2](#). Orientation of the triangular pointer does not denote direction of movement. It is aligned with the horizontal line in the datum target symbol and pointed to the left or right. The leader extends from the tip of the triangle.

6.3.28 Surface Texture Symbols

For information on the symbolic means of specifying surface texture, see ASME Y14.36M.

6.3.29 Symbols for Limits and Fits

For information on the symbolic means of specifying metric limits and fits, see [para. 5.2.1](#).

6.3.30 Datum Reference Frame Symbol

The symbolic means for indicating a datum reference frame is shown in [Figures 6-8](#) through [6-10](#), [7-1](#), and [7-2](#). The datum reference frame symbol shall consist of the X, Y, and Z coordinate labels applied to the axes of the datum reference frame.

6.3.31 Dynamic Profile Tolerance Zone Modifier

The symbolic means for specifying the refinement of the form independent of size of a considered feature that is controlled by a profile tolerance is shown in [Figures 6-12](#) and [11-35](#) through [11-38](#). See [subsection 11.10](#).

6.3.32 “From-To” Symbol

The symbolic means to indicate that a specification transitions from one location to a second location is shown in [Figures 6-12](#) and [11-12](#). The leader from the feature control frame shall be directed to the portion of the feature to which that tolerance applies. [Figure 11-12](#), for example, shows three tolerance transitions that go from A to B, from B to C, and from C to D. The “from” and “to” locations may be points, lines, or features.

6.4 FEATURE CONTROL FRAME SYMBOLS

Geometric characteristic symbols, the tolerance value, modifiers, and datum feature reference letters, where applicable, are combined in a feature control frame to express a geometric tolerance. The symbols may also be used in drawing notes and engineering documentation.

6.4.1 Feature Control Frame

Each feature control frame is a rectangle divided into compartments and shall have 1 of the 12 geometric characteristic symbols and a tolerance. Where applicable, the tolerance shall be preceded by the diameter or spherical diameter symbol and followed by a material condition modifier and any other modifier. Datum feature references shall also be included where applicable. See [Figures 6-24](#), [7-2](#), and [10-4](#).

6.4.2 Feature Control Frame Incorporating One Datum Feature Reference

When a geometric tolerance is related to a datum, this relationship shall be indicated by entering the datum feature reference letter in a compartment following the

tolerance. Where applicable, the datum feature reference letter shall be followed by a material boundary modifier. See [Figure 6-25](#).

6.4.3 Feature Control Frame Incorporating Two or Three Datum Feature References

When more than one datum feature reference is required, the datum feature reference letters (each followed by a material boundary modifier, where applicable) are entered in separate compartments in the desired order of precedence, from left to right. See [Figure 6-26](#), illustrations (b) and (c). Datum feature reference letters need not be in alphabetical order in the feature control frame.

6.4.4 Composite Feature Control Frame

A composite feature control frame contains a single geometric characteristic symbol (position or profile) followed by two or more segments, each containing tolerance and any required datum references, one above the other. See [Figure 6-27](#), illustration (a) and [paras. 10.5.1](#) and [11.6](#).

6.4.5 Multiple Single-Segment Feature Control Frames

The symbolic means of representing multiple single-segment feature control frames shall have a geometric symbol for each segment as shown in [Figure 6-27](#), illustration (b). Application of this control is described in [para. 10.5.2](#).

6.4.6 Combined Feature Control Frame and Datum Feature Symbol

When a feature or pattern of features controlled by a geometric tolerance also serves as a datum feature, the feature control frame and datum feature symbol may be combined. The datum feature symbol may be attached to the feature control frame. In the positional tolerance example in [Figure 6-28](#), a feature is controlled for position in relation to datums A and B, and the controlled feature is identified as datum feature C.

6.4.7 Feature Control Frame With a Projected Tolerance Zone

When a positional or an orientation tolerance is specified as a projected tolerance zone, the projected tolerance zone symbol shall be placed in the feature control frame following the stated tolerance and any applicable material condition modifier. The dimension indicating the

minimum projection of the tolerance zone shall follow the projected tolerance zone symbol except as follows. See [Figures 6-29](#) and [10-22](#). Where orthographic views are used and it is necessary for clarification, the projected tolerance zone shall be indicated with a chain line and the minimum projection of the tolerance zone shall be specified in a drawing view. In this case, the projection dimension indicating the minimum projection of the tolerance zone may be omitted from the feature control frame. See [Figure 10-23](#). In a model, the projection direction is established as being on the side of the part where the tolerance specification leader terminates on the part.

6.5 FEATURE CONTROL FRAME PLACEMENT

A feature control frame shall be related to a considered feature by one of the following methods and as depicted in [Figure 6-30](#):

- (a) locating the frame below or beside a leader-directed note or dimension pertaining to the feature
- (b) attaching a leader from the frame pointing to the feature or an extension line relating to the feature
- (c) attaching a side, corner, or end of the frame to an extension line from the feature
- (d) attaching a side, corner, or end of the frame to an extension of the dimension line pertaining to a feature of size
- (e) placing the feature control frame in a note, chart, or the general tolerance block
- (f) attaching the feature control frame to another feature control frame that is placed according to one of the methods in (a) through (d)

6.6 TOLERANCE ZONE SHAPE

When the specified tolerance value represents the diameter of a cylindrical or spherical zone, the diameter or spherical diameter symbol shall precede the tolerance value. When the tolerance zone is other than cylindrical or spherical, the diameter symbol or spherical diameter symbol shall be omitted, and the specified tolerance value represents the full width of the tolerance zone and is applied as explained in [Sections 7](#) through [12](#). In some cases, the tolerance zone is nonuniform and shall be specified as described in [para. 11.3.2](#).

6.7 TABULATED TOLERANCES

When the tolerance in a feature control frame is tabulated, a letter representing the tolerance, preceded by the abbreviation "TOL," shall be entered as shown in [Figure 6-31](#).

Figure 6-1 Geometric Characteristic Symbols

CHARACTERISTIC	SYMBOL	CHARACTERISTIC	SYMBOL	CHARACTERISTIC	SYMBOL
STRAIGHTNESS	—	PROFILE OF A LINE		PARALLELISM	//
FLATNESS		PROFILE OF A SURFACE		POSITION	
CIRCULARITY		ANGULARITY		CIRCULAR RUNOUT	
CYLINDRICITY		PERPENDICULARITY		TOTAL RUNOUT	

* Arrowheads may be filled or not filled

6.3.1
3.64

Figure 6-2 Datum Feature Symbol

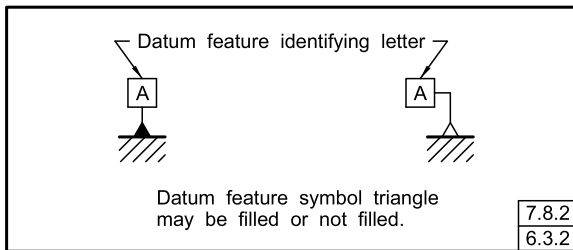

Figure 6-3 Datum Feature Symbols on a Feature Surface and an Extension Line

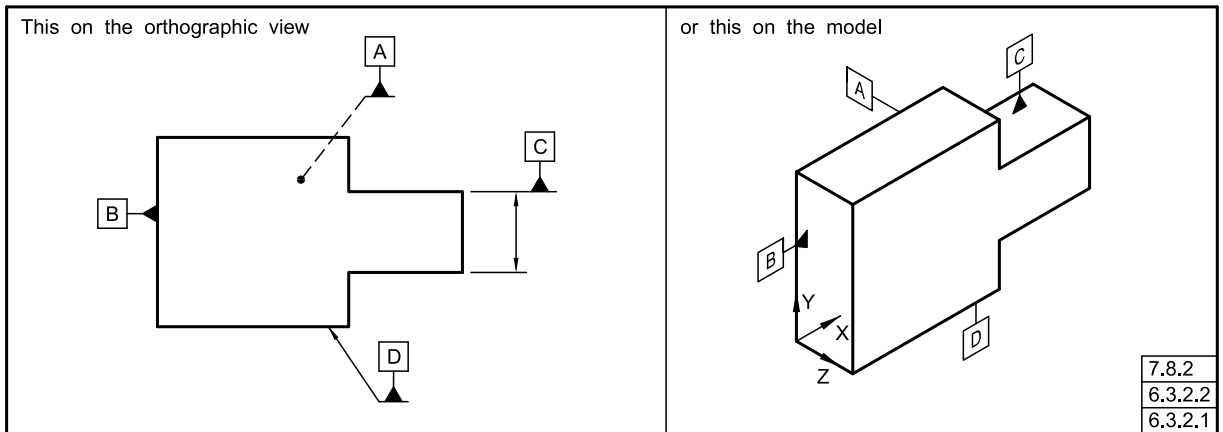

Figure 6-4 Placement of Datum Feature Symbols on Features of Size

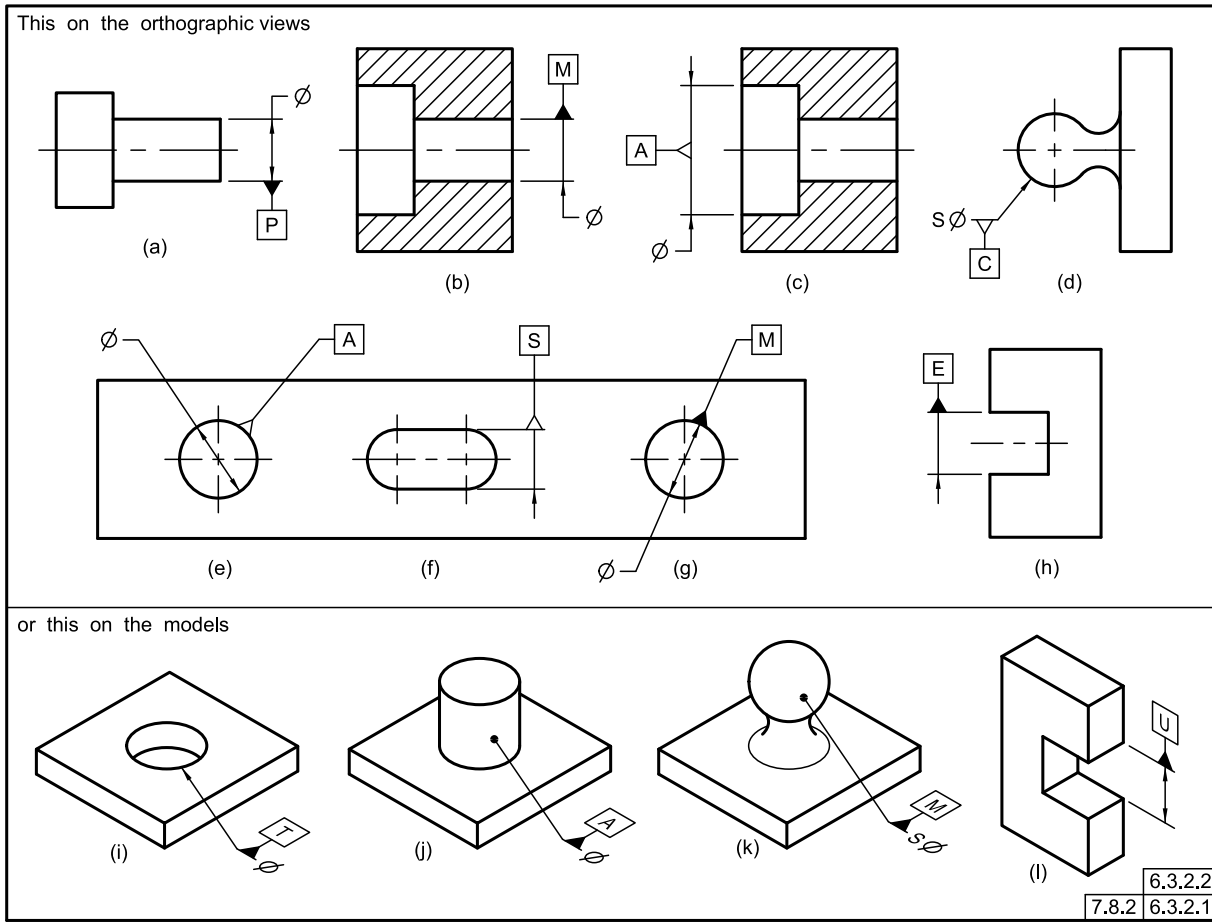

Figure 6-5 Placement of Datum Feature Symbol in Conjunction With a Feature Control Frame

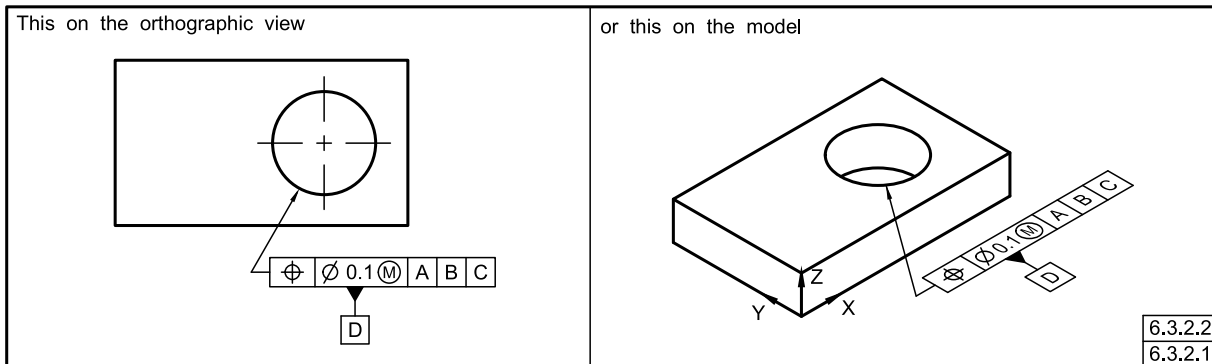

Figure 6-6 Two Datum Features Establishing a Single Datum Plane

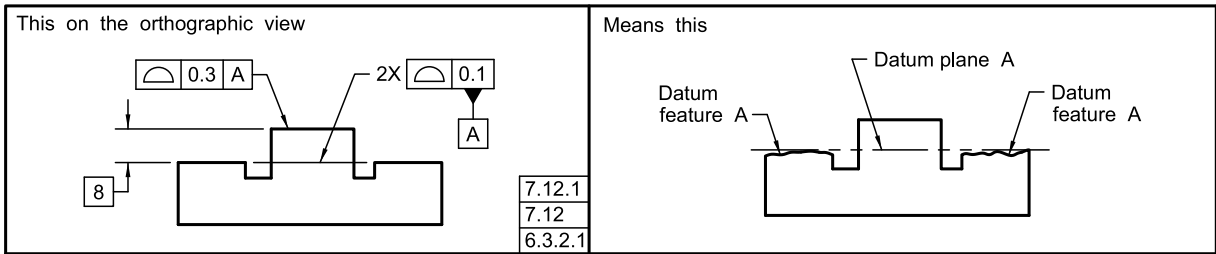

Figure 6-7 Datum Target Symbol Examples

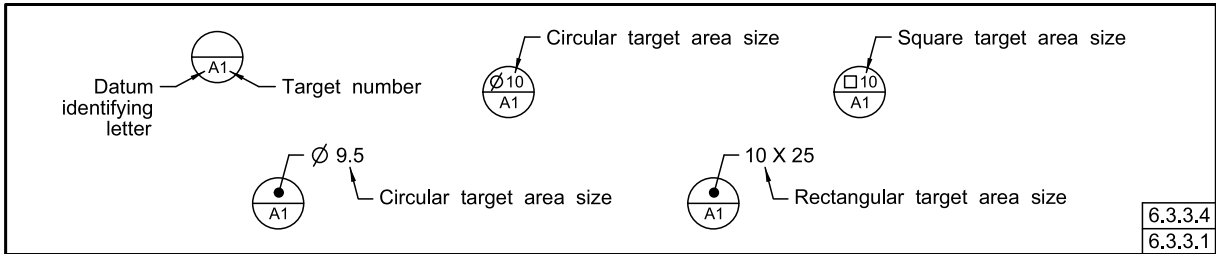

Figure 6-8 Datum Target Point

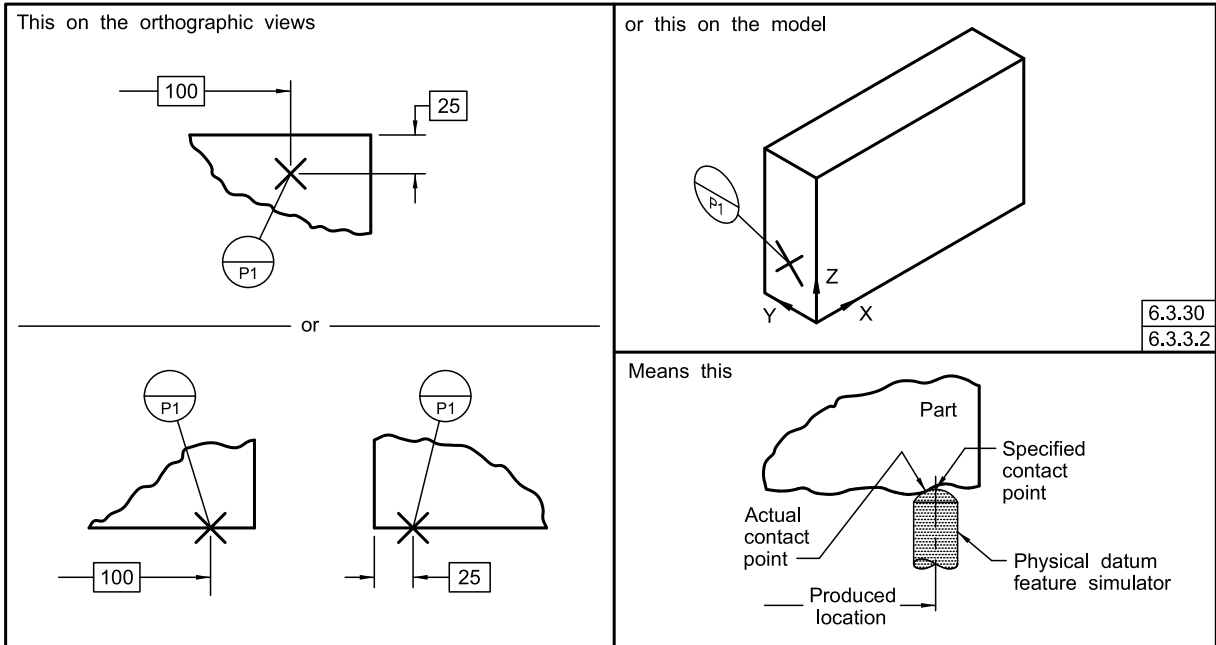

Figure 6-9 Datum Target Line

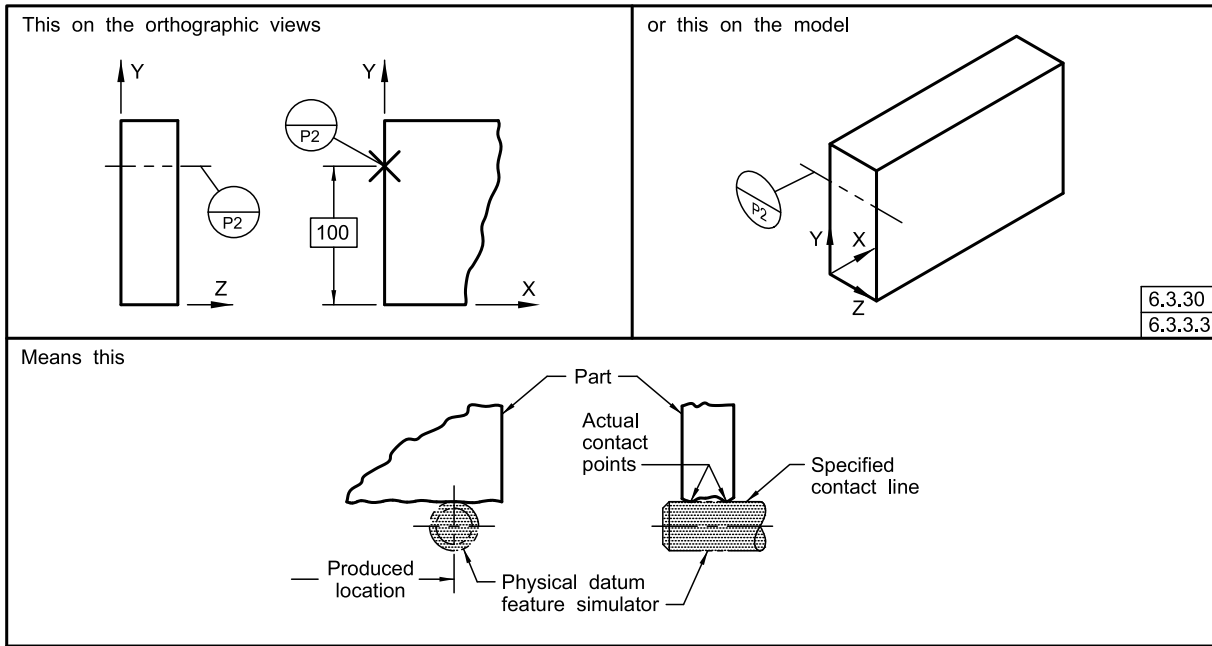

Figure 6-10 Datum Target Area

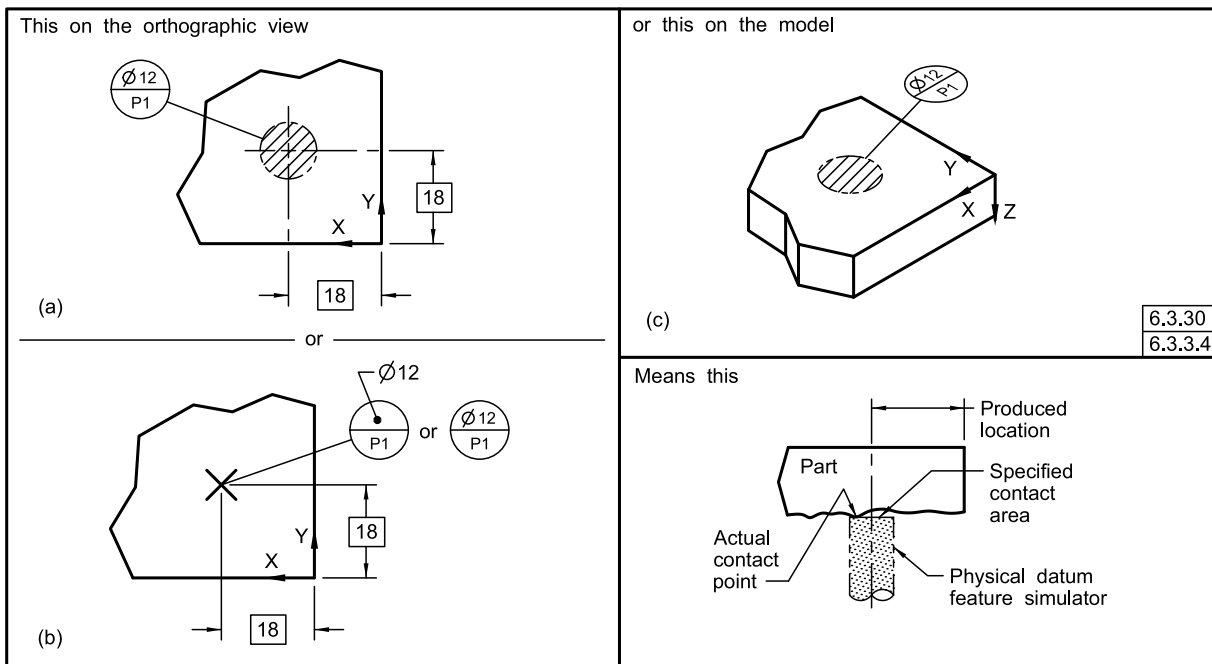

Figure 6-11 Basic Dimension Symbol Application

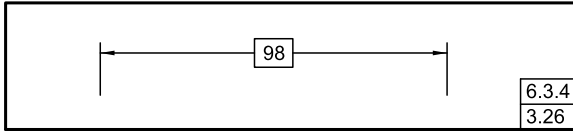

Figure 6-12 Modifying Symbols

TERM	SYMBOL	SEE	TERM	SYMBOL	SEE
MAXIMUM MATERIAL CONDITION (when applied to a tolerance value) MAXIMUM MATERIAL BOUNDARY (when applied to a datum reference)	Ⓜ	6.3.5	SPHERICAL DIAMETER	S∅	6.3.7
LEAST MATERIAL CONDITION (when applied to a tolerance value) LEAST MATERIAL BOUNDARY (when applied to a datum reference)	Ⓛ	6.3.5	RADIUS	R	6.3.7
TRANSLATION	▷	6.3.26	SPHERICAL RADIUS	SR	6.3.7
PROJECTED TOLERANCE ZONE	Ⓟ	6.3.6	CONTROLLED RADIUS	CR	6.3.7
FREE STATE	ⓕ	6.3.20	SQUARE	□	6.3.16
TANGENT PLANE	Ⓣ	6.3.21	REFERENCE	()	6.3.8
UNEQUALLY DISPOSED PROFILE	Ⓤ	6.3.22	ARC LENGTH	⤿	6.3.9
INDEPENDENCY	Ⓢ	6.3.24	DIMENSION ORIGIN	⊕→	6.3.17
STATISTICAL TOLERANCE	ⓈT	6.3.10	BETWEEN	↔	6.3.11
CONTINUOUS FEATURE	ⓈF	6.3.23	ALL AROUND	⊕↻	6.3.19
DIAMETER	∅	6.3.7	ALL OVER	⊕⊕	6.3.25
			DYNAMIC PROFILE	△	6.3.31
			FROM - TO	→	6.3.32

Figure 6-13 Indicating That the Specified Tolerance Is a Statistical Geometric Tolerance

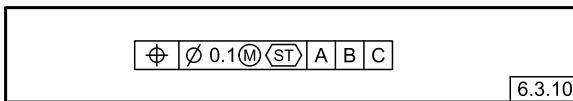

Figure 6-14 Statistical Tolerance Symbol

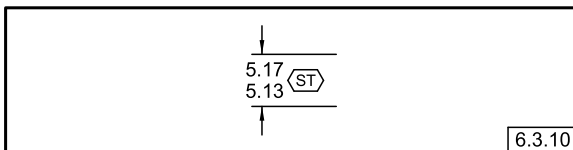

Figure 6-15 “Between” Symbol

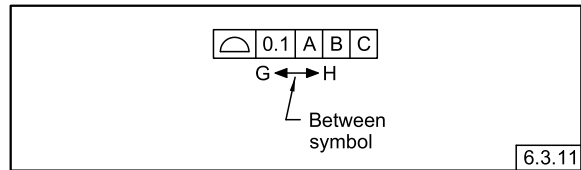

Figure 6-16 Counterbore and Spotface Symbols

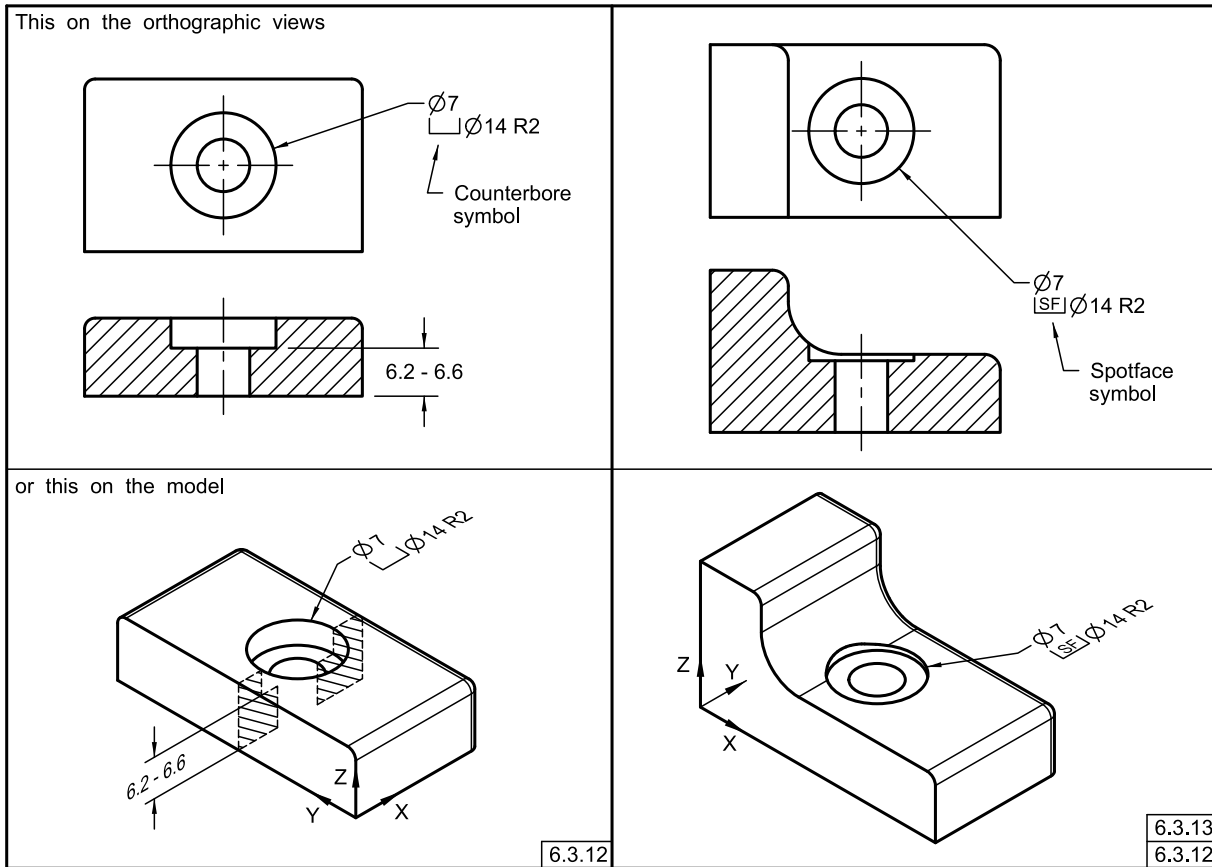

Figure 6-17 Countersink Symbol

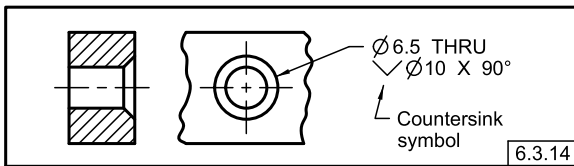

Figure 6-18 Depth Symbol

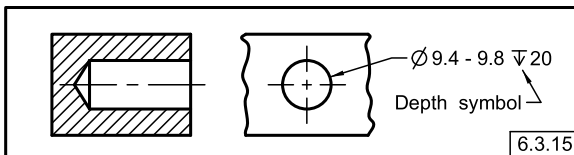

Figure 6-19 Square Symbol

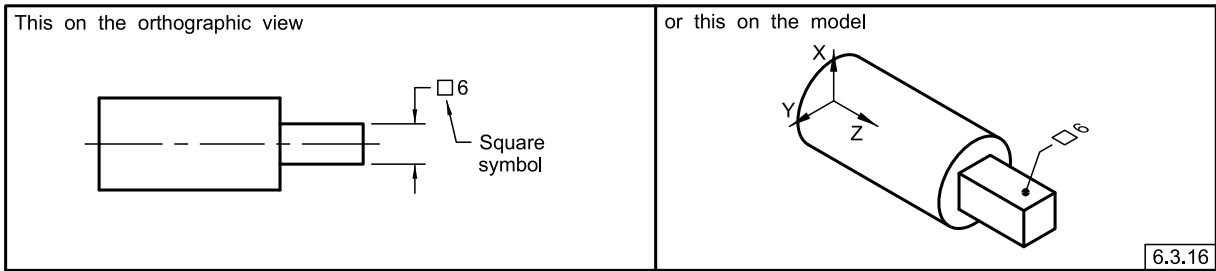

Figure 6-20 Dimension Origin Symbol

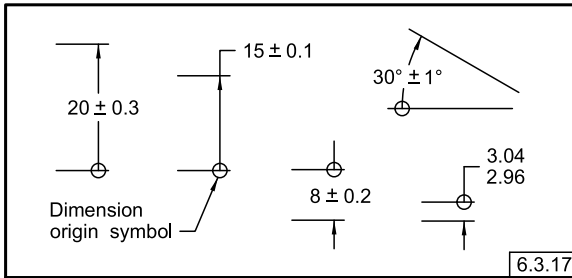

Figure 6-23 Application of “Movable Datum Target” Symbol

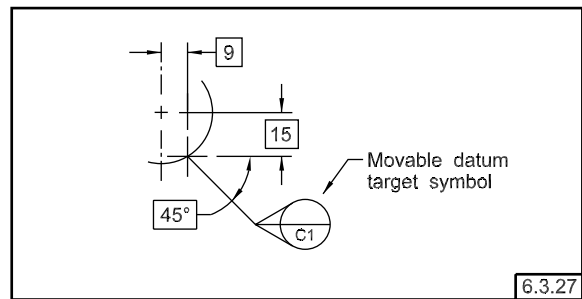

Figure 6-21 Application of “All Over” and “All Around” Symbols

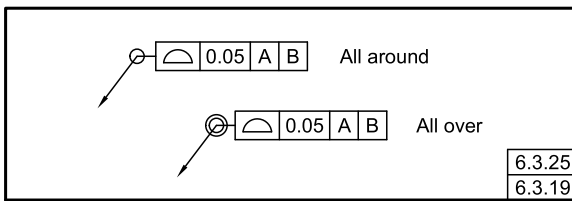

Figure 6-24 Feature Control Frame

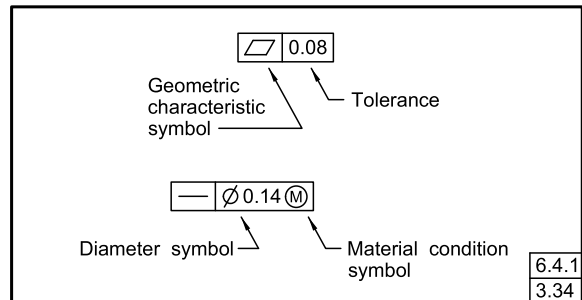

Figure 6-22 Feature Control Frame With “Free State” Symbol

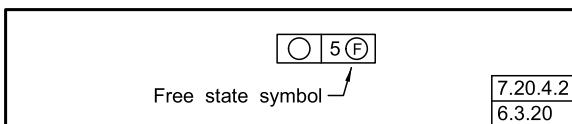

Figure 6-25 Feature Control Frame Incorporating a Datum Feature Reference

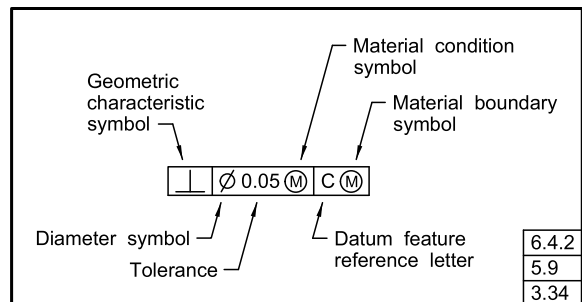

Figure 6-26 Order of Precedence of Datum Feature Reference

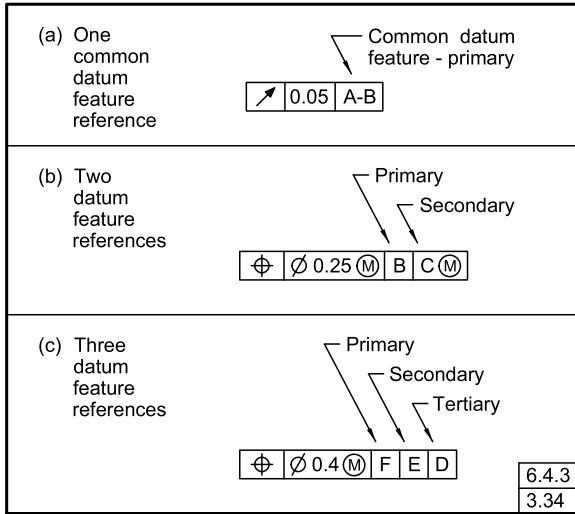

Figure 6-27 Multiple Feature Control Frames

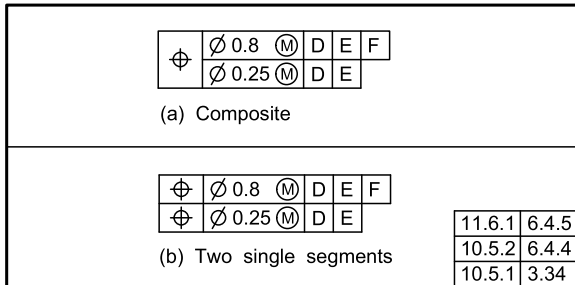

Figure 6-28 Combined Feature Control Frame and Datum Feature Symbol

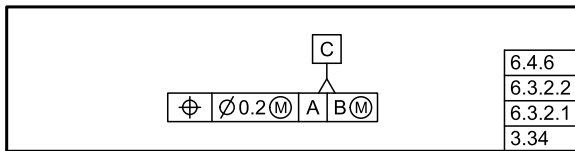

Figure 6-29 Feature Control Frame With a Projected Tolerance Zone Symbol

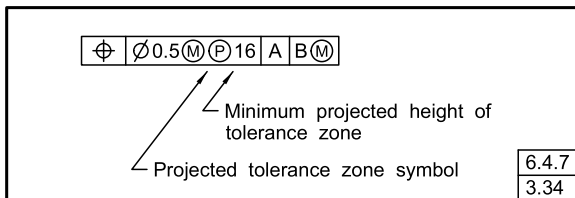

Figure 6-30 Feature Control Frame Placement

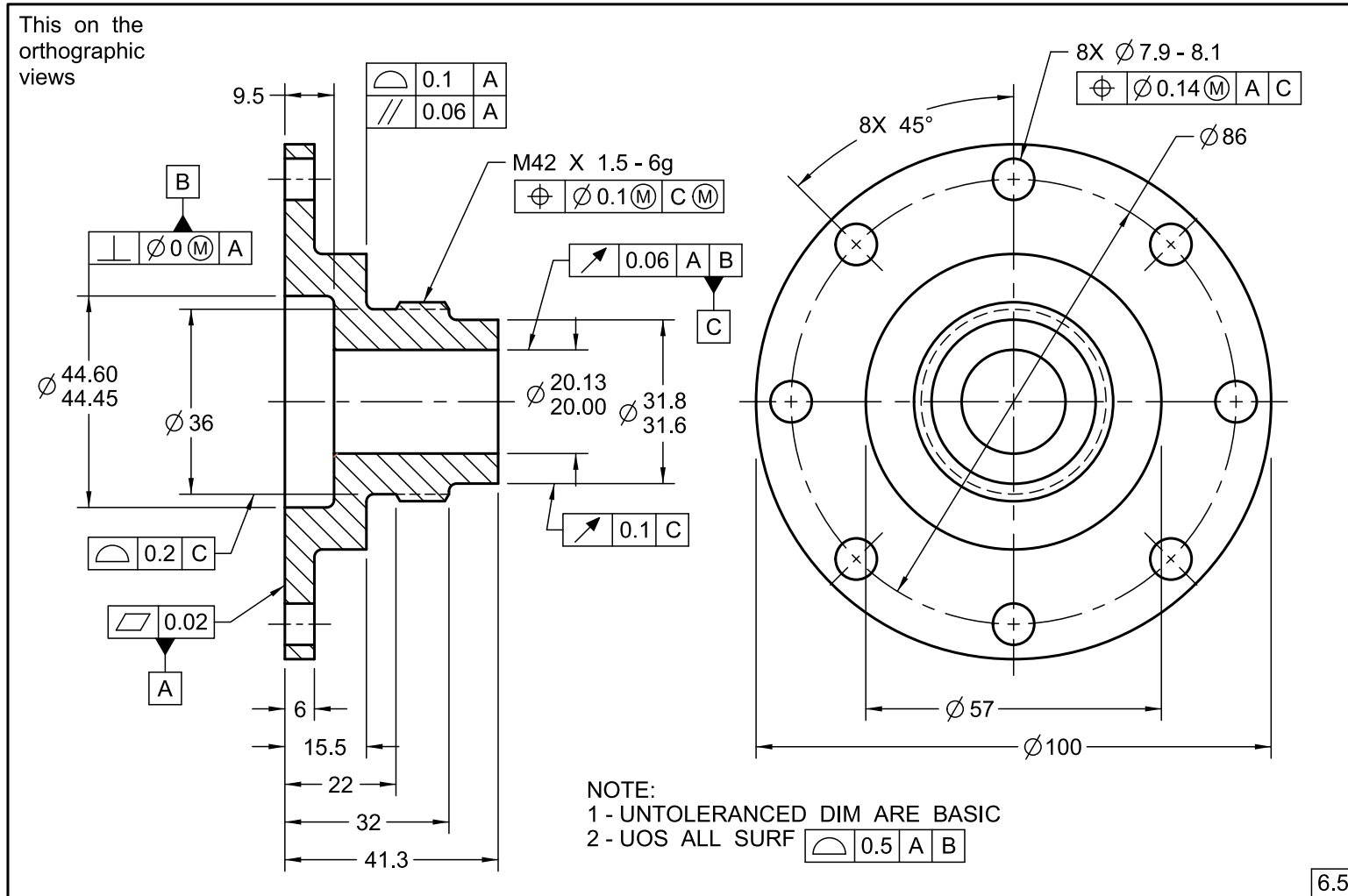

Figure 6-30 Feature Control Frame Placement (Cont'd)

or this on the model

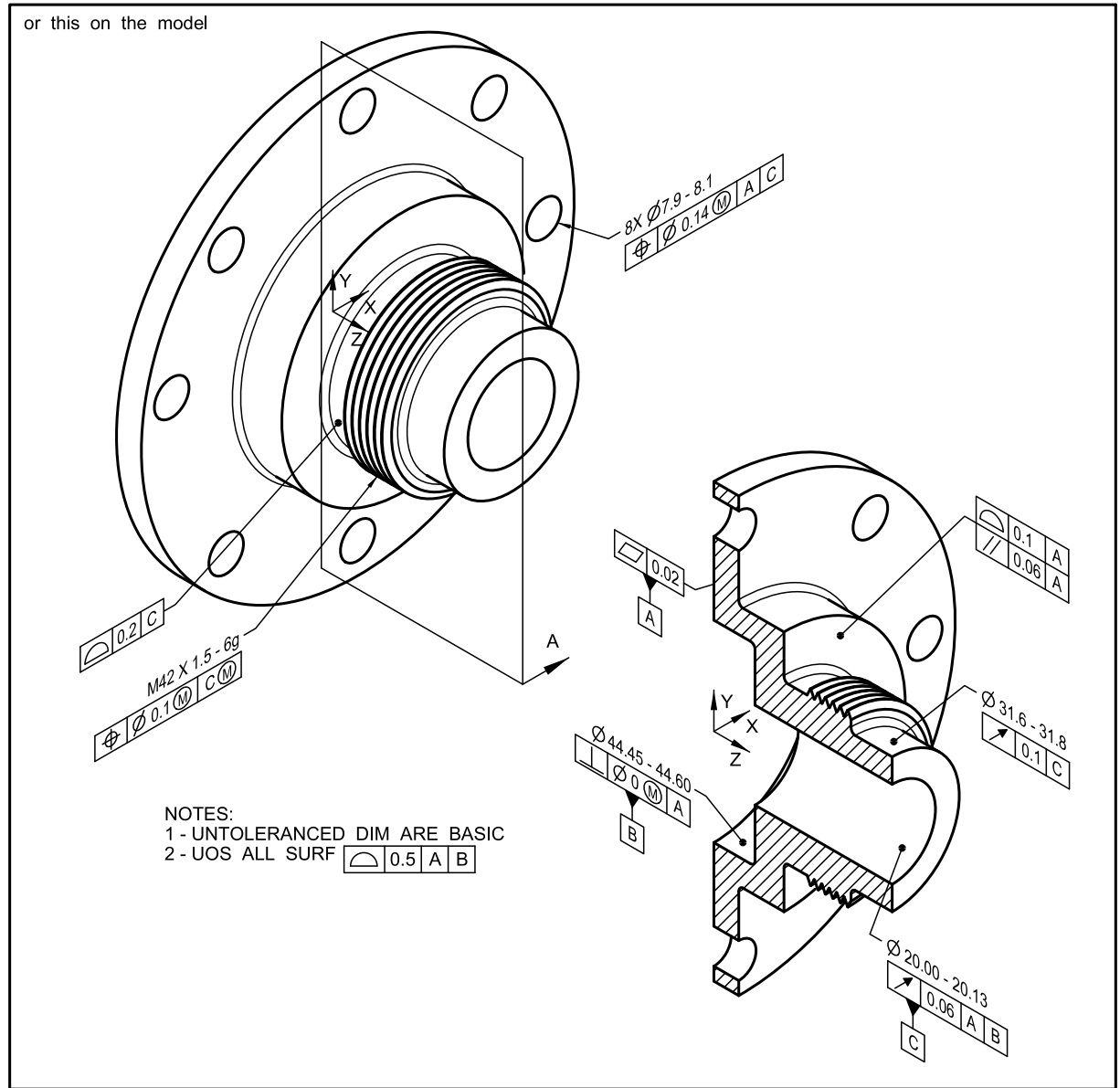
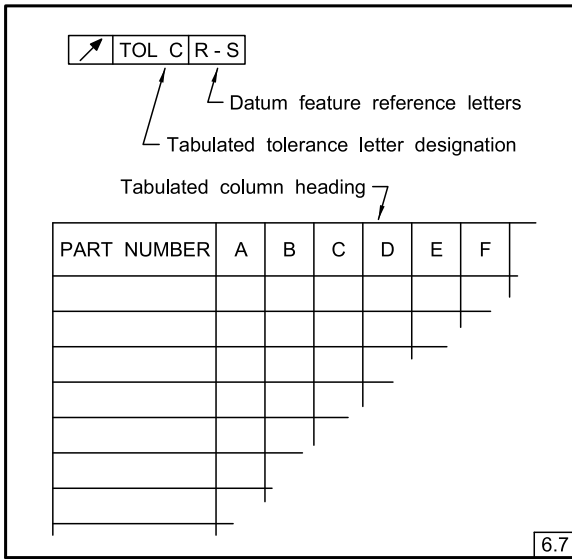

Figure 6-31 Tabulated Tolerances



Section 7

Datum Reference Frames

7.1 GENERAL

This Section establishes the principles of identifying features as datum features for the purpose of establishing relationships imposed by geometric tolerances and for constraining degrees of freedom. This Section also establishes the criteria for establishing datums and the datum reference frame using true geometric counterparts derived from datum features.

7.2 DEGREES OF FREEDOM

All parts have six degrees of freedom, three translational and three rotational, that may be constrained by datum feature references in a feature control frame. The three translational degrees of freedom are termed x , y , and z . The three rotational degrees of freedom are termed u , v , and w . See [Figure 7-1](#) and [Figure 7-2](#), illustrations (c), (d), and (e).

NOTE: In the “Means this” portion of some figures in this Standard, the translational and rotational degrees of freedom are annotated as in [Figures 7-2](#) and [7-56](#) to aid the user in interpreting the drawing.

7.3 DEGREES OF FREEDOM CONSTRAINED BY PRIMARY DATUM FEATURES RMB

The relationship between the primary datum feature and its true geometric counterpart constrains degrees of freedom. See [Figure 7-3](#) for some examples of degrees of freedom constrained by primary datum features RMB. Although collections of features may be used to establish a single datum, for simplicity, the chart in [Figure 7-3](#) illustrates only single datum features. The degrees of freedom constrained depend on whether the datum feature is referenced as a primary, a secondary, or a tertiary datum feature. See [Figures 7-2](#), [7-9](#), and [7-14](#). The following primary datums are derived from the associated true geometric counterpart:

(a) A planar datum feature (nominally flat) establishes a true geometric counterpart that creates a datum plane and constrains three degrees of freedom (one translational and two rotational). See [Figure 7-3](#), illustration (a).

(b) A width as a datum feature (two opposed parallel surfaces) establishes a true geometric counterpart that creates a datum center plane and constrains three

degrees of freedom (one translational and two rotational). See [Figure 7-3](#), illustration (b).

(c) A spherical datum feature establishes a true geometric counterpart that creates a datum center point and constrains three degrees of freedom (all translational). See [Figure 7-3](#), illustration (c).

(d) A cylindrical datum feature establishes a true geometric counterpart that creates a datum axis (line) and constrains four degrees of freedom (two translational and two rotational). See [Figure 7-3](#), illustration (d).

(e) A conical-shaped datum feature establishes a true geometric counterpart that creates a datum axis and a datum point and constrains five degrees of freedom (three translational and two rotational). See [Figure 7-3](#), illustration (e).

(f) The datum feature of the linear extruded shape shown in [Figure 7-3](#), illustration (f) establishes a true geometric counterpart that creates a datum plane and a datum axis and constrains five degrees of freedom (two translational and three rotational).

(g) The complex datum feature shown in [Figure 7-3](#), illustration (g) establishes a true geometric counterpart that creates a datum plane, a datum point, and a datum axis and constrains six degrees of freedom (three translational and three rotational).

7.4 CONSTRAINING DEGREES OF FREEDOM OF A PART

Where datum features are referenced, the part is constrained relative to the applicable true geometric counterparts in the specified order of precedence to establish the datum reference frame. This establishes the relationships that exist between the geometric tolerance zones and the datum reference frame. See [Figures 7-2](#) and [7-4](#) through [7-6](#). True geometric counterparts are used to associate the datum features and the datums. This constrains the motion (degrees of freedom) between the part and the associated datum reference frame.

NOTE: The sequence of establishing a datum reference frame from datum features and true geometric counterparts is described in [subsection 7.3](#). In subsequent text, for brevity, this process is described as “establishing a datum reference frame from datum features.”

7.5 TRUE GEOMETRIC COUNTERPART

A true geometric counterpart, as defined in [subsection 3.66](#), shall be the inverse shape of the datum feature, UOS. See [Figures 7-7](#) through [7-11](#).

7.5.1 Types of True Geometric Counterparts

A true geometric counterpart may be one of the following:

- (a) an MMB
- (b) an LMB
- (c) a related AME
- (d) an unrelated AME
- (e) a related actual minimum material envelope
- (f) an unrelated actual minimum material envelope
- (g) a tangent plane
- (h) a datum target(s)
- (i) a mathematically defined contour

7.5.2 Requirements of True Geometric Counterparts

True geometric counterparts have the following requirements:

- (a) perfect form.
- (b) basic orientation relative to one another for all the datum references in a feature control frame.
- (c) basic location relative to other true geometric counterparts for all the datum references in a feature control frame, unless a translation modifier or “movable datum target” symbol is specified. See [Figures 7-6](#), [7-12](#), and [7-38](#).
- (d) movable location when the translation modifier or the “movable datum target” symbol is specified. See [Figures 7-12](#), [7-39](#), and [7-59](#).
- (e) fixed at the designated size, when MMB or LMB is specified.
- (f) adjustable in size, when the datum feature applies RMB.

NOTE: Some of the requirements in (a) through (f) above are not applicable when a customized datum reference frame is specified.

7.6 TRUE GEOMETRIC COUNTERPARTS AND PHYSICAL DATUM FEATURE SIMULATORS

This Standard defines engineering specifications relative to theoretical datums established from true geometric counterparts. In the practical application, measurements cannot be made from datums or true geometric counterparts; therefore, simulated datums are established using physical datum feature simulators. For example, machine tables and surface plates, though not true planes, are of such quality that the planes derived from them are used to establish the simulated datums from which measurements are taken and dimensions verified. See [Figure 7-7](#). Also, for example, ring and plug gages and mandrels, though not true cylinders, are of such quality that their

axes are used as simulated datums from which measurements are taken and dimensions verified. See [Figures 7-8](#) and [7-9](#). When magnified surfaces of manufactured parts are seen to have irregularities, contact is made with a true geometric counterpart at a number of surface extremities or high points. The principles in this Standard are based on true geometric counterparts and do not take into account any tolerances or error in the physical datum feature simulators. See ASME Y14.43.

NOTE: There are many ways to accomplish the practical application (i.e., datum feature simulator). For purposes of describing the theoretical concepts in this Standard, contact or interaction between the part and the true geometric counterpart, rather than the imperfect physical datum feature simulator, is described.

7.7 DATUM REFERENCE FRAME

Sufficient datum features or designated portions of these features are chosen to position the part in relation to one or more planes of the datum reference frame. This reference frame exists in theory only and not on the part. See [Figure 7-1](#). Therefore, it is necessary to establish a method of simulating the theoretical reference frame from the actual features of the part. In practice, the features are associated with physical or mathematical elements that simulate the true geometric counterparts in a stated order of precedence and according to applicable modifiers. This constrains the applicable degrees of freedom between the part and the associated datum reference frame. See [Figures 7-2](#), [7-4](#), [7-5](#), [7-13](#), and [7-14](#).

7.7.1 Mutually Perpendicular Planes

The planes of the datum reference frame are simulated in a mutually perpendicular relationship to provide direction as well as the origin for related dimensions. This theoretical reference frame constitutes the three-plane dimensioning system used for dimensioning and tolerancing.

7.7.2 Number of Datum Reference Frames

In some cases, a single datum reference frame is sufficient. In others, additional datum reference frames may be necessary when physical separation or the functional relationship of features requires that different datum reference frames be applied. In such cases, each feature control frame shall contain the applicable datum feature references. Any difference in the order of precedence or in the material boundary of any datum features referenced in multiple feature control frames requires different datum simulation methods and, consequently, establishes a different datum reference frame. See [Figure 7-15](#).

7.8 DATUM FEATURES

A datum feature is selected on the basis of its functional relationship to the tolerated feature and the requirements of the design. See [Figures 7-4, 7-5, and 7-43 through 7-45](#). To ensure proper assembly, corresponding interfacing features of mating parts should be selected as datum features. However, a datum feature should be accessible on the part and of sufficient size to permit its use. Datum features shall be readily discernible on the part. Therefore, in the case of symmetrical parts or parts with identical features, physical identification of the datum feature on the part may be necessary.

7.8.1 Temporary and Permanent Datum Features

Features of in-process parts, such as castings, forgings, machinings, or fabrications, may be used as temporary datum features to create permanent datum features. Such temporary datum features may or may not be subsequently removed by machining. Permanent datum features should be surfaces or diameters not appreciably changed by subsequent processing operations.

7.8.2 Datum Feature Identification

Datum features are physical features identified on the drawing by means of a datum feature symbol, datum target symbol(s), or a note. See [Figures 6-2 through 6-4](#).

7.9 DATUM FEATURE CONTROLS

Geometric tolerances related to a datum reference frame do not take into account any variations in form, orientation, or location of the datum features. Datum features shall be controlled by applying appropriate geometric tolerances and/or by size dimensions. To make it possible to calculate the true geometric counterpart boundaries of each datum feature in a datum reference frame, a relationship between the datum features shall be specified. Tolerances applied that affect a datum feature or the relationship between datum features include the following:

(a) primary datum feature(s) size and form (see [Figures 7-2 and 7-4](#)) and/or the location between features in a pattern used to establish the primary datum (see [Figures 7-16 and 7-17](#)).

(b) secondary datum feature(s) size, orientation, and/or location, as applicable, to a higher-precedence datum (see [Figures 7-2, 7-4, 7-18, 7-32, and 7-33](#)); where a pattern of features serves to establish the secondary datum, the location between features in the pattern and the pattern's orientation, location, or both to a higher-precedence datum shall be applicable.

(c) tertiary datum feature(s) size, orientation, and/or location to higher-precedence datums, as applicable (see [Figures 7-2 and 7-4](#)); where a pattern of features serves to establish the tertiary datum, the location between features

in the pattern and the pattern's orientation, location, or both to higher-precedence datums shall be applicable.

7.10 SPECIFYING DATUM FEATURES IN AN ORDER OF PRECEDENCE

Datum features shall be specified in an order of precedence to constrain a part relative to the datum reference frame. The desired order of precedence shall be indicated by entering the appropriate datum feature reference letters, from left to right, in the feature control frame. [Figure 7-2](#) illustrates a part where the datum features are planar surfaces.

7.10.1 Development of a Datum Reference Frame for Parts With Planar Surface Datum Features

The feature control frame in [Figure 7-2](#) illustrates the datum reference frame for the part shown in its functional assembly in illustration (b). [Figure 7-2](#) illustrates the development of the datum reference frame along with degrees of freedom. The datum features referenced in the feature control frame fully constrain the six degrees of freedom (three translational and three rotational) to establish a datum reference frame. Relating a part to a true geometric counterpart and a datum reference frame in this manner ensures consistency in meaning of specified engineering requirements. See [Figure 7-1](#).

(a) In [Figure 7-2](#), illustration (a), datum feature D is referenced as the primary datum feature. Where a surface is specified as a datum feature, the high point(s) on the surface establish a datum plane. This primary datum feature contacts the true geometric counterpart on a minimum of three points (see [para. 7.11.2](#) for discussion on rocking or unstable datum features). In this example, where the primary datum feature contacts the true geometric counterpart, three degrees of freedom (one translational and two rotational) are constrained: rotation about the X -axis (u), rotation about the Y -axis (v), and translation in the z direction.

(b) Datum feature E is referenced as the secondary datum feature. This feature contacts the true geometric counterpart at a minimum of two points while the contact established in (a) is maintained. See [Figure 7-2](#), illustration (d). In this example, where the secondary datum feature contacts its true geometric counterpart, two degrees of freedom (one translational and one rotational) are constrained: translation in the x direction and rotation about the Z -axis (w).

(c) Datum feature F is referenced as the tertiary datum feature. This datum feature contacts its true geometric counterpart at a minimum of one point while the contacts established in (a) and (b) are maintained. See [Figure 7-2](#), illustration (e). In this example, where the tertiary datum feature contacts its true geometric counterpart, the

remaining degree of freedom is constrained: translation in the y direction.

7.10.2 Parts With Inclined Datum Features

For parts with inclined datum features as shown in [Figure 7-13](#), a true geometric counterpart plane is oriented at the basic angle of the datum feature. The corresponding plane of the datum reference frame passes through the vertex of the basic angle and is mutually perpendicular to the other two planes.

7.10.3 Parts With Cylindrical Datum Features

The datum of a cylindrical datum feature is the axis of the true geometric counterpart. This axis serves as the origin for relationships defined by geometric tolerances. See [Figures 7-8, 7-9, and 7-14](#). A primary cylindrical datum feature is always associated with two theoretical planes intersecting at right angles on the datum axis. Depending on the number of planes established by higher-precedence datums, secondary and tertiary datum axes may establish zero, one, or two theoretical planes.

7.10.3.1 Cylindrical Datum Feature. [Figure 7-14](#) illustrates a part with a cylindrical datum feature. Primary datum feature K relates the part to the first datum plane. Since secondary datum feature M is cylindrical, it is associated with two theoretical planes, the second and third in a three-plane relationship.

7.10.3.2 Datum Axis and Two Planes. The two theoretical planes are represented on an orthographic view by center lines crossing at right angles, as in [Figure 7-14](#), illustration (a). The intersection of these planes coincides with the datum axis. See [Figure 7-14](#), illustration (b). Once established, the datum axis becomes the origin for related dimensions.

7.10.3.3 Orientation of Two Planes. No rotational constraint of the second and third planes of the datum reference frame in [Figure 7-14](#) is specified, as rotation of the pattern of holes about the datum axis has no effect on the function of the part. In such cases, only the following two datum features are referenced in the feature control frame:

(a) primary datum feature K, which establishes a datum plane

(b) secondary datum feature M, which establishes a datum axis perpendicular to datum plane K

7.10.4 Constraining Rotational Degrees of Freedom

To constrain the rotational degree of freedom of two planes about a datum axis, a lower-precedence datum feature is referenced in the feature control frame. See subsection [7.16](#).

(a) [Figure 7-4](#) illustrates the constraint of the rotational degree of freedom of the two planes intersecting through the secondary datum feature B, established by the center plane of the tertiary datum feature C. [Figure 7-5](#) illustrates the development of the datum reference frame for the positional tolerance of the three holes in [Figure 7-4](#).

(b) [Figure 7-6](#) illustrates the constraint of the rotational degree of freedom of the two planes intersecting through the secondary datum feature B. Constraint is established by the tertiary datum feature C.

(c) [Figures 7-30 through 7-39](#) illustrate the constraint of the rotational degree of freedom of the two planes intersecting through datum feature A. Constraint is established by datum feature B.

7.11 ESTABLISHING DATUMS

[Paragraphs 7-11.1 through 7-11.17](#) define the criteria for establishing datums using the true geometric counterparts of datum features.

7.11.1 Plane Surfaces as Datum Features

Where a nominally flat surface is specified as a datum feature, the corresponding true geometric counterpart is a plane contacting high points of that surface. See [Figure 7-7](#). The minimum number of points contacted by the true geometric counterpart depends on whether the surface is a primary, a secondary, or a tertiary datum feature. See [para. 7.10.1](#).

7.11.2 Irregularities on Datum Features Applicable RMB

If irregularities on a datum feature are such that the part is unstable (i.e., it rocks) when it is brought into contact with the corresponding true geometric counterpart, the default requirement is that the part be adjusted to a single solution that minimizes the separation between the feature and the true geometric counterpart per ASME Y14.5.1M. If a different procedure is desired (candidate datum set, Chebychev, least squares, translational least squares, etc.), it shall be specified.

7.11.3 Effect of Specified Material Boundary on Datum Feature References

The boundary applicable to datum features referenced in a feature control frame affects the relationship of the part to the datum reference frame. RMB is implied when no modifier is shown. MMB or LMB modifiers may be applied to any datum feature reference, except where the primary datum feature is planar. See [Figures 7-19 and 7-20](#).

7.11.4 Datum Features Applicable RMB

When a datum feature or collection of datum features applies RMB in a feature control frame, the true geometric counterpart geometry originates at the MMB and progresses proportionally through the tolerance zone to make maximum possible contact with the datum feature or collection of features. If another fitting routine is required, it shall be stated on the drawing.

As a practical example, a machine element that is variable (such as a chuck, mandrel, vise, or centering device) is used as a physical datum feature simulator of the datum feature and to establish the simulated datum.

(a) *Primary Datum Feature — Cylinder RMB.* The datum is the axis of the true geometric counterpart of the datum feature. The true geometric counterpart (or unrelated AME) is the smallest circumscribed (for an external feature) or largest inscribed (for an internal feature) perfect cylinder that makes maximum possible contact with the datum feature surface. See [Figure 7-3](#), illustration (d) and [Figures 7-8](#) and [7-9](#).

(b) *Primary Datum Feature — Width RMB.* The datum is the center plane of the true geometric counterpart of the datum feature. The true geometric counterpart (or unrelated AME) is two parallel planes at minimum separation (for an external feature) or maximum separation (for an internal feature) that make maximum possible contact with the corresponding surfaces of the datum feature. See [Figure 7-3](#), illustration (b) and [Figures 7-10](#) and [7-11](#).

(c) *Primary Datum Feature — Sphere RMB.* The datum is the center point of the true geometric counterpart of the datum feature. The true geometric counterpart (or unrelated AME) is the smallest circumscribed (for an external feature) or largest inscribed (for an internal feature) perfect sphere that makes maximum possible contact with the datum feature surface. See [Figure 7-3](#), illustration (c).

(d) *Primary Datum Feature — Complex Features RMB.* Simulation of a complex feature referenced as primary RMB may result in a difficult simulation requirement. For these applications, the specification of datum targets; a datum feature referenced at [BSC], with the abbreviation “BSC” meaning basic; or an alternatively defined stabilization method may be used. See [Figure 7-29](#).

(e) *Secondary Datum Feature RMB — Cylinder or Width.* For both external and internal features, the secondary datum (axis or center plane) is established in the same manner as indicated in (a) and (b) with an additional requirement. The theoretical cylinder or parallel planes of the true geometric counterpart shall be oriented and/or located to the primary datum feature’s true geometric counterpart. Datum feature B in [Figure 7-21](#) illustrates this principle for cylinders, and [Figure 7-38](#) illustrates the same principle for widths. In [Figure 7-38](#), the secondary true geometric counterpart RMB

expands and makes maximum possible contact, constraining all possible remaining degrees of freedom.

(f) *Tertiary Datum Feature — Cylinder or Width RMB.* For both external and internal features, the tertiary datum (axis or center plane) is established in the same manner as indicated in (e) with an additional requirement. The theoretical cylinder or parallel planes of the true geometric counterpart shall be oriented and/or located to both the primary and secondary datum features’ true geometric counterparts. A width tertiary datum feature may be located to a datum axis as in [Figure 7-21](#) or offset from a plane of the datum reference frame. [Figure 7-6](#) illustrates the same principle for a cylinder.

(g) *Secondary and Tertiary Datum Features — Sphere RMB.* The secondary or tertiary datum (center point) is established in the same manner as indicated in (c) with an additional requirement that the theoretical center point is located relative to higher-precedence datum features’ true geometric counterparts. The true geometric counterpart for a translatable secondary or tertiary spherical datum feature is established in the same manner as for a primary one as stated in (c).

(h) *Secondary and Tertiary Surfaces RMB.* Where the datum feature (secondary or tertiary) is a surface, RMB applied to the datum feature requires the true geometric counterpart to expand, contract, or progress normal to the true profile of the feature from its MMB to its LMB until the true geometric counterpart makes maximum possible contact with the extremities of the datum feature while respecting the higher-precedence datum(s). See [Figures 7-30](#), [7-32](#), and [7-34](#).

7.11.5 Specifying Datum Features at MMB

Where MMB is applied to a datum feature referenced in a feature control frame, it establishes the true geometric counterpart of the appropriate boundary. The appropriate boundary is determined by the collective effects of size and any applicable geometric tolerances relative to any higher-precedence datums. As a practical example, when a datum feature is applied on an MMB basis, machine and gaging elements in the processing equipment that remain constant may be used to simulate a true geometric counterpart of the feature and to establish the simulated datum. To determine the applicable boundary, see [para. 7.11.6](#).

7.11.6 Determining the Size of True Geometric Counterparts at MMB

An analysis of geometric tolerances applied to a datum feature is necessary in determining the size of the datum feature’s true geometric counterpart. A feature of size or a pattern of features of size serving as a datum feature may have several MMBs. These include the MMC of a datum feature of size and the collective effects of MMC and geometric tolerances. Datum feature precedence shall

be respected, except in the case of a customized datum reference frame. See subsection 7.22. When an MMB equal to MMC is the design requirement for a given datum feature, a zero geometric tolerance at MMC is specified to the datum feature as shown on datum features B and C in Figure 7-22. See para. 10.3.4 and Figure 9-14.

(a) The appropriate MMB for determining the size of the true geometric counterpart for an internal datum feature(s) of size is the largest MMB that the datum feature(s) of size can contain while respecting the datum feature precedence.

(b) The appropriate MMB for determining the size of the true geometric counterpart for an external datum feature(s) of size is the smallest MMB that can contain the datum feature(s) of size while respecting the datum feature precedence. See Figure 7-22 for examples of calculating the size of MMB.

7.11.6.1 Determining the Appropriate MMB. Datum feature D in Figure 7-22 has three MMBs. For an external feature of size, the appropriate MMB is the smallest boundary that can contain the datum feature of size while respecting datum feature precedence.

(a) Where datum feature D is referenced as primary, collective effects of MMC (7.1 dia.) and the straightness tolerance (0.1 dia.) establish an MMB of 7.2 dia. See option (a) in the table shown in Figure 7-22.

(b) Where datum feature D is referenced as secondary, to ensure that datum precedence is not violated, the collective effects of the MMC (7.1 dia.) and the perpendicularity tolerance (0.2 dia.) establish an MMB of 7.3 dia. See option (b) in the table shown in Figure 7-22.

(c) Where datum feature D is referenced as tertiary, to ensure that datum precedence is not violated, the collective effects of the MMC (7.1 dia.) and the position tolerance (0.4 dia.) establish an MMB of 7.5 dia. Since the perpendicularity tolerance is a refinement of the position tolerance, it is not additive. See option (c) in the table shown in Figure 7-22.

7.11.6.2 Calculations for the MMB. For the position tolerance applied to datum feature D in Figure 7-22, the appropriate MMBs for datum features B and C are 10.2 dia. (10.2 MMC minus 0 perpendicularity tolerance) and 1.4 (1.4 MMC minus 0 position tolerance), respectively.

7.11.7 Specifying Datum Features at LMB

Where LMB is applied to a datum feature referenced in a feature control frame, it establishes the true geometric counterpart at the appropriate boundary. The appropriate boundary is determined by the collective effects of size and any applicable geometric tolerances relative to any higher-precedence datums. To determine the applicable boundary, see para. 7.11.8.

7.11.8 Determining the Size of True Geometric Counterparts at LMB

An analysis of geometric tolerances applied to a datum feature is necessary in determining the size of the datum feature's true geometric counterpart. A feature or a pattern of features serving as a datum feature may have several LMBs. These include the LMC of a feature or the collective effects of LMC and geometric tolerances. Datum feature precedence shall be respected, except in the case of a customized datum reference frame. See subsection 7.22. When an LMB equal to LMC is the design requirement for a given datum feature, a zero geometric tolerance at LMC is specified to the datum feature, as shown on datum features B and C in Figure 7-23. See para. 10.3.5.3.

(a) The appropriate LMB for determining the size of the true geometric counterpart for an internal datum feature(s) is the smallest LMB that can contain the feature(s) of size while respecting datum feature precedence.

(b) The appropriate LMB for determining the size of the true geometric counterpart for an external datum feature(s) is the largest LMB that the datum feature(s) of size can contain while respecting datum feature precedence. See Figure 7-23 for examples of calculating the size of LMB.

7.11.8.1 Determining the Correct LMB. Datum feature D in Figure 7-23 has three LMBs. For an external feature of size, the appropriate LMB is the largest boundary that the datum feature of size can contain while respecting datum feature precedence.

(a) Where datum feature D is referenced as primary, collective effects of LMC (8.2 dia.) and the straightness tolerance (0.1 dia.) establish an LMB of 8.1 dia. See option (a) in the table shown in Figure 7-23.

(b) Where datum feature D is referenced as secondary, to ensure that datum precedence is not violated, the collective effects of the LMC (8.2 dia.) and the perpendicularity tolerance (0.3 dia.) establish an LMB of 7.9 dia. See option (b) in the table shown in Figure 7-23.

(c) Where datum feature D is referenced as tertiary, to ensure that datum precedence is not violated, the collective effects of the LMC (8.2 dia.) and the position tolerance (0.6 dia.) establish an LMB of 7.6 dia. Since the perpendicularity tolerance is a refinement of the position tolerance, it is not additive. See option (c) in the table shown in Figure 7-23.

7.11.8.2 Calculations for the LMB. For the position tolerance applied to datum feature D, the appropriate LMBs for datum features B and C are 10.8 dia. (10.8 LMC plus 0 perpendicularity tolerance) and 1.8 (1.8 LMC plus 0 position tolerance), respectively.

7.11.9 Specifying Datum Features RMB

Where RFS is applicable to the tolerances applied to a datum feature and RMB is applicable to the datum feature reference in a feature control frame, there is no fixed-size true geometric counterpart. The true geometric counterpart shall contract to fit an external datum feature and expand to fit an internal datum feature. For an external feature, there is a maximum external boundary that is the collective effects of size, form, and any applicable geometric tolerances relative to any higher-precedence datums. For an internal feature, there is a minimum internal boundary that is the collective effects of size, form, and any applicable geometric tolerances relative to any higher-precedence datums. As a practical example, where a datum feature of size is applied on an RMB basis, machine and gaging elements in the process equipment shall be able to expand or contract as required to establish the simulated datum. To determine the applicable boundary, see [para. 7.11.9.1](#).

7.11.9.1 Determining a Worst-Case Material Boundary (RMB). Datum feature D in [Figure 7-24](#) has three OBs resulting from the tolerances applied to the datum feature and the datum reference applied RMB. For an external feature of size, the maximum OB is the smallest envelope that the datum feature does not violate with that envelope constrained to any higher-precedence datums.

(a) Where datum feature D is referenced as primary, collective effects of MMC (7.9 dia.) and the straightness tolerance (0.1 dia.) establish an OB of 8 dia. See option (a) in the table shown in [Figure 7-24](#).

(b) Where datum feature D is referenced as secondary, to ensure that datum precedence is not violated, the collective effects of the MMC (7.9 dia.), the perpendicularity tolerance (0.3 dia.), and the straightness tolerance of 0.1 dia. establish an OB of 8.3 dia. See option (b) in the table shown in [Figure 7-24](#).

(c) Where datum feature D is referenced as tertiary, to ensure that datum precedence is not violated, the collective effects of the MMC (7.9 dia.), the position tolerance (0.6 dia.), and the straightness tolerance of 0.1 dia. establish an OB of 8.6 dia. Because straightness applied to a feature of size controls the derived median line, and position controls the axis of the unrelated AME, the form and position tolerances accumulate. Since the perpendicularity tolerance (0.3 dia.) is a refinement of the position tolerance, it is not additive. See option (c) in the table shown in [Figure 7-24](#).

7.11.10 Explicit Specification of True Geometric Counterpart Boundaries

In cases where the boundary is not clear or another boundary is required, the value of a fixed-size boundary shall be stated, enclosed in brackets, following the applicable datum feature reference and any modifier, such as

the “free state” symbol, in the feature control frame. RMB, MMB, and LMB are not applicable when the size of the simulator is specified. The boundary may also be specified by including a numeric value preceded by a diameter symbol, radius symbol, spherical diameter, or spherical radius symbol, as applicable, between the brackets.



To indicate that the true geometric counterpart is defined by the basic dimensions of the true profile of the datum feature, the term “[BSC],” meaning basic, shall follow the datum reference letter in the feature control frame. See [Figure 7-35](#).



7.11.11 Datum Feature Shift/Displacement

MMB or LMB modifiers applied to the datum feature reference allow the datum feature to shift/displace from the boundary established by the true geometric counterpart in an amount that is equal to the difference between the applicable (unrelated or related) AME for MMB, actual minimum material envelope for LMB, or surface of the feature and the true geometric counterpart. The datum reference frame is established from the true geometric counterpart and not the datum features. See [Figure 7-25](#) for LMB; [Figures 7-16](#), [7-18](#), and [7-26](#) for MMB; and [Figure 7-33](#) for a surface referenced as a datum feature at MMB. The datum feature shift/displacement shall always be limited or constrained by the true geometric counterpart. Where the true geometric counterpart geometry does not fully limit or constrain the feature, such as where it may rotate away from the true geometric counterpart as shown in [Figure 7-36](#), an extremity of the datum feature shall remain between the MMB and the LMB. See [para. 7.16.7](#).

7.11.12 Translation Modifier

When it is necessary to indicate that the basic location of the true geometric counterpart is unlocked and the true geometric counterpart is able to translate within the specified geometric tolerance to fully engage the feature, the translation modifier shall be added to the feature control frame following the datum feature reference and any other applicable modifiers. See [Figure 7-12](#), illustration (a), [Figure 7-39](#), and [para. 6.3.26](#). When the translation modifier is applicable and the direction of movement is not clear, movement requirements shall be specified. A coordinate system for the applicable datum reference frame is added and the direction of movement is indicated using a unit vector designation consisting of “*i, j, k*” components (corresponding to the *X*-axis, *Y*-axis, and *Z*-axis of the coordinate system), placed in brackets and following the translation modifier symbol. See [Figure 7-12](#), illustrations (b)

and (c). The vector notation shall contain the number of decimal places necessary to achieve adequate precision. The true geometric counterpart may translate in either direction (positive or negative) along this vector.

7.11.13 Effects of Datum Precedence and Datum Feature Material Boundary Conditions

When datums are specified in an order of precedence, the material boundary at which each datum feature applies shall be determined. The effect of the applicable material boundary and order of precedence should be considered relative to fit and function of the part. [Figures 7-19](#) and [7-20](#) illustrate a part with a pattern of holes located in relation to cylindrical datum feature A and flat surface datum feature B. As indicated by asterisks, datum feature references may be specified in different ways.

7.11.14 Cylindrical Feature RMB Primary

In [Figure 7-20](#), illustration (b), diameter A is the primary datum feature and RMB is applicable; surface B is the secondary datum feature. The datum axis is the axis of the true geometric counterpart. The true geometric counterpart is the smallest circumscribed cylinder that contacts cylindrical feature A, and that circumscribing cylinder is the unrelated AME of diameter A. This cylinder encompasses variations in the size and form of A within specified limits. However, any variation in perpendicularity between surface B and diameter A, the primary datum feature, affects the degree of contact of surface B with its true geometric counterpart.

7.11.15 Surface Primary, Cylindrical Feature RMB Secondary

In [Figure 7-19](#), illustration (b), surface B is the primary datum feature, diameter A is the secondary datum feature, and RMB is applicable. Datum axis A is the axis of the smallest circumscribed cylinder that contacts cylindrical feature A, the circumscribing cylinder is perpendicular to the primary datum plane B, and the circumscribing cylinder is the related AME of the diameter A. In addition to size and form variations, this cylinder encompasses any variation in perpendicularity between diameter A and primary datum B.

7.11.16 Surface Primary, Cylindrical Feature at MMB Secondary

In [Figure 7-19](#), illustration (c), surface B is the primary datum feature, diameter A is the secondary datum feature, and MMB is applied. Datum axis A is the axis of a fixed-size cylindrical true geometric counterpart that is perpendicular to datum plane B. A displacement of the datum feature is allowed when there is clearance between

datum feature A and its true geometric counterpart. See [para. 10.3.6.2](#).

7.11.17 Cylindrical Feature at MMB Primary

In [Figure 7-20](#), illustrations (c) and (d), diameter A is the primary datum feature and MMB is applied; surface B is the secondary datum feature and RMB applies. Datum A is the axis of the true geometric counterpart of fixed size at MMB. Because datum feature A is primary, any variation in perpendicularity between surface B and datum axis A may affect the degree of contact of surface B with its true geometric counterpart. Where datum feature A departs from MMB, relative movement (translation or rotation) can occur between datum axis A and the axis of the unrelated AME of datum feature A. See [para. 10.3.6.2](#).

7.12 COMMON DATUM FEATURES

When more than one datum feature is used to establish a true geometric counterpart for a single datum, the appropriate datum feature reference letters and associated modifiers, separated by a dash, are entered in one compartment of the feature control frame. See [para. 7.21\(b\)](#) and [Figure 7-27](#). Since the datum features are equally important, datum feature reference letters may be entered in any order within this compartment. Where no material boundary modifier is applied, the default RMB condition (Rule #2) applies. Where MMB or LMB is the required boundary condition, the MMB or LMB boundary modifier shall be applied following each datum feature reference letter. Where the intent is clear, a single datum feature reference letter may be used to define the multiple surfaces as a single datum feature. See [paras. 6.3.2.1\(g\)](#) and [7.12.1](#) and [Figure 6-6](#). Where applicable, each datum feature reference letter shall be followed by a material boundary modifier.

7.12.1 Simulation of a Single Datum Plane

[Figure 6-6](#) is an example of a single datum plane simulated by the true geometric counterpart simultaneously contacting the high points of two surfaces. Identification of two features to establish a single datum plane may be required where separation of the features is caused by an obstruction, such as in [Figure 6-6](#), or by a comparable opening (e.g., a slot). For controlling coplanarity of these surfaces, see [Figure 6-6](#) and [para. 11.4.1.1](#).

7.12.2 Single Axis of Two Coaxial Features of Size

[Figures 7-16](#) and [7-17](#) are examples of a single datum axis established from the axes of the true geometric counterparts that simultaneously constrain the two coaxial diameters. The datum features in [Figure 7-16](#) may be specified applicable RMB or specified to apply at MMB

or LMB, as applicable. In [Figure 7-17](#), the datum features for the runout tolerances can only apply RMB.

7.12.3 Pattern of Features of Size at MMB

Multiple features of size, such as a pattern of holes at MMB, may be used as a group in the establishment of a true geometric counterpart to derive a datum reference frame. See [Figure 7-18](#). In this case, when the part is mounted on the true geometric counterpart of primary datum feature A, the pattern of holes establishes the true geometric counterpart that is used to derive the second and third planes of the datum reference frame. The true geometric counterpart of datum feature B is the collection of the MMBs of all of the holes located at true position. The origin of the datum reference frame may be established at the center of the pattern of the true geometric counterpart where it intersects plane A, as shown in [Figure 7-18](#), or at any other location defined with basic dimensions relative to the true geometric counterpart as in [Figure 7-29](#). Where datum feature B is referenced at MMB, relative movement (translation and/or rotation) of the datum features is allowed when there is clearance between the datum features and their true geometric counterparts. This relative movement is related to any clearance between the surfaces of datum feature B and the MMB of each hole. This clearance is affected by the size, orientation, and location of all holes collectively.

7.12.4 Pattern of Features of Size RMB

When RMB is applicable in a feature control frame to common datum features of size used to establish a single datum, the true geometric counterpart of each feature shall be fixed in location relative to one another. The true geometric counterparts shall expand or contract simultaneously from their worst-case material boundary to their LMB until the true geometric counterparts make maximum possible contact with the extremities of the datum feature(s). When irregularities on the feature(s) may allow the part to be unstable, a single solution shall be defined to constrain the part. See [Figure 7-17](#).

7.12.5 Partial Surfaces as Datum Features

It is often desirable to specify only part of a surface, instead of the entire surface, to serve as a datum feature. In addition to the methods specified in [\(a\)](#) and [\(b\)](#) below, it is permissible to specify a partial surface in note form or by a datum target.

(a) Orthographic Views. A chain line drawn parallel to the surface profile and dimensioned to define the area and location as in [Figure 7-28](#) indicates a partial feature as a datum feature.

(b) Models. Supplemental geometry indicates a partial feature as a datum feature. See [Figure 7-28](#) and ASME Y14.41.

7.13 MATHEMATICALLY DEFINED SURFACE

Where a compound curve or contoured surface is used as a datum feature, it shall be mathematically defined in a three-dimensional coordinate system. When such a feature is referenced as a datum feature, its true geometric counterpart (derived from the math data) is used in establishing the datum reference frame. Aligning the high points of the datum feature with its true geometric counterpart constrains the part relative to the datum reference frame. When the datum feature alone does not adequately constrain the required degrees of freedom of the part, additional datum features are required. See [Figure 7-29](#).

7.14 MULTIPLE DATUM REFERENCE FRAMES

More than one datum reference frame may be necessary for certain parts, depending on functional requirements. When more than one datum reference frame is used and it is necessary to determine the relationships and calculate boundaries between the reference frames, the relationship between the datum reference frames shall be specified. In [Figure 7-15](#), datum features A and B establish one datum reference frame, while datum features C and D establish a different datum reference frame. Datum features C and D have tolerances applied that reference datums A and B, thus establishing the relationship between the datum reference frames. Neither datum reference frame constrains all six degrees of freedom. The hole patterns in the two ends are separate requirements and have no datum reference that constrains rotation of one pattern of holes to the other.

7.15 FUNCTIONAL DATUM FEATURES

Only the required datum features should be referenced in feature control frames when specifying geometric tolerances. An understanding of the geometric control provided by these tolerances (as explained in [Sections 8 through 12](#)) is necessary to determine the number of datum feature references required for a given application. The functional requirements of the design should be the basis for selecting the related datum features to be referenced in the feature control frame. [Figures 7-43 through 7-45](#) illustrate parts in an assembly where geometric tolerances are specified, each having the required number of datum feature references.

7.16 ROTATIONAL CONSTRAINT ABOUT A DATUM AXIS OR POINT

Where a datum reference frame is established from a primary or secondary datum axis or point, a lower-precedence datum feature surface or feature of size may be used to constrain rotation. See [para. 7.10.4](#). Depending on functional requirements, there are many ways to constrain the rotational degrees of freedom about the higher-precedence datum. [Figures 7-30 through 7-39](#) illustrate the

development of a datum reference frame based on the principles outlined in the true geometric counterpart requirements. In these figures, datum feature A establishes an axis and the lower-precedence datum feature B is located (positioned or profiled) to datum feature A and is then used to orient the rotational degrees of freedom to establish the datum reference frame that is used to locate the two 6-mm-dia. holes. Depending on functional requirements, this lower-precedence datum feature may apply RMB or be modified to apply at MMB or LMB. The datum reference frame is established from the true geometric counterparts and not from the datum features.

7.16.1 Contoured Datum Feature RMB Constraining a Rotational Degree of Freedom

In [Figure 7-30](#), datum feature B applies RMB. This requires the true geometric counterpart geometry to originate at the MMB of R14.9 and progress through the profile tolerance zone toward the LMB of R15.1 until it makes maximum contact with datum feature B and constrains the rotational degree of freedom of the part around the axis of the true geometric counterpart from datum feature A.

7.16.2 Contoured Datum Feature at MMB Constraining a Rotational Degree of Freedom

In [Figure 7-31](#), datum feature B is modified to apply at MMB. This requires the true geometric counterpart to be fixed at the MMB of R14.9 and thus orients the two planes that originate at the axis of the true geometric counterpart of datum feature A. Where datum feature B departs from MMB, relative movement (rotation) can occur between the true geometric counterpart for datum feature B and the related AME of datum feature B. Datum feature B may rotate within the confines created by its departure from MMB and might not remain in contact with the true geometric counterpart.

7.16.3 Planar Datum Feature RMB Constraining a Rotational Degree of Freedom

In [Figure 7-32](#), datum feature B applies RMB. This requires the true geometric counterpart geometry to originate at the MMB of 15.1 and progress through the profile tolerance zone toward the LMB of 14.9 until it makes maximum contact with datum feature B and constrains the rotational degree of freedom of the part around the axis of the true geometric counterpart of datum feature A.

7.16.4 Planar Datum Feature at MMB Constraining a Rotational Degree of Freedom

In [Figure 7-33](#), datum feature B is modified to apply at MMB. This requires the true geometric counterpart to be fixed at the MMB of 15.1 and thus orients the two planes that originate at the axis of the true geometric counterpart of datum feature A. Where datum feature B departs from MMB, relative movement (rotation) can occur between the true geometric counterpart for datum feature B and the related AME of datum feature B. Datum feature B may rotate within the confines created by its departure from MMB and might not remain in contact with the true geometric counterpart.

7.16.5 Offset Planar Datum Feature RMB Constraining a Rotational Degree of Freedom

In [Figure 7-34](#), datum feature B is offset relative to datum axis A and applies RMB. This requires the true geometric counterpart to meet the following conditions:

(a) The true geometric counterpart geometry originates at the MMB of 5.1 and progresses through the profile tolerance zone toward the LMB of 4.9 until it makes maximum contact with datum feature B.

(b) The true geometric counterpart constrains the rotational degree of freedom of the part around the axis of the true geometric counterpart of datum feature A.

7.16.6 Offset Planar Datum Feature Set at Basic, Constraining a Rotational Degree of Freedom

In [Figure 7-35](#), datum feature B is offset 5 relative to datum axis A. RMB does not apply as it is overridden in the feature control frame for the two holes by “[BSC]” following the reference to datum feature B. See [para. 7.11.10](#). This requires the true geometric counterpart to be fixed at 5 basic and the datum feature shall make contact with the true geometric counterpart. This constrains the rotational degree of freedom of the two planes of the datum reference frame around the axis of the true geometric counterpart of datum feature A.

7.16.7 Offset Planar Datum Feature at MMB Constraining a Rotational Degree of Freedom

In [Figure 7-36](#), datum feature B is offset relative to datum axis A and the datum feature reference is modified to apply at MMB. This requires the true geometric counterpart to be fixed at the MMB of 5.1 and constrains the rotational degree of freedom of the two planes of the datum reference frame that originate at the true geometric counterpart of datum feature A. The part may rotate on datum axis A provided one or more maximum material

extremities of datum feature B remain between the MMB and LMB for that feature.

7.16.8 Offset Planar Datum Features at LMB Constraining a Rotational Degree of Freedom

In [Figure 7-37](#), datum feature B is offset relative to datum axis A and the datum feature reference is modified to apply at LMB. This requires the true geometric counterpart to be fixed at the LMB of 4.9 and constrains the rotational degree of freedom of the two planes of the datum reference frame that originate at the true geometric counterpart of datum feature A. The part may rotate on datum axis A provided one or more least material extremities of datum feature B remain between the MMB and LMB.

7.16.9 Datum Feature of Size RMB Constraining a Rotational Degree of Freedom

In [Figure 7-38](#), datum feature B applies RMB and is position toleranced relative to datum axis A. This requires the center plane of the datum feature B simulator geometry to be fixed at the basic 5 dimension and the true geometric counterpart geometry to expand until it makes maximum contact with datum feature B. This constrains the rotational degree of freedom of the two planes of the datum reference frame around the axis of the true geometric counterpart of datum feature A.

7.16.10 Datum Feature of Size RMB With Translation Modifier Constraining Rotational Degrees of Freedom

In [Figure 7-39](#), datum feature B applies RMB with a translation modifier. This allows the center plane of the true geometric counterpart to translate while maintaining its orientation to higher-precedence datums. The parallel planes of the true geometric counterpart expand to make maximum contact with the datum feature.

7.17 APPLICATION OF MMB, LMB, AND RMB TO IRREGULAR FEATURES OF SIZE

MMB, LMB, and RMB apply to irregular features of size when they are selected as datum features.

(a) In some applications, irregular features of size that contain or may be contained by an AME or actual minimum material envelope from which a center point, an axis, or a center plane can be derived may be used as datum features. See [para. 3.35.1\(a\)](#) and [Figures 7-40](#) through [7-42](#). MMB, LMB, and RMB principles apply to these types of irregular features of size.

(b) In other applications (such as an irregular shaped feature) where a boundary has been defined using profile tolerancing, a center point, an axis, or a center plane may not be readily definable. See [para. 3.35.1\(b\)](#) and [Figure 11-29](#). MMB and LMB principles may be applied to this type of

irregular feature of size. When RMB is applicable, the fitting routine may be the same as for a regular feature of size, or a specific fitting routine may be defined, or datum targets may be used.

NOTE: Datum feature reference RMB may become very complex or not be feasible for some irregular features of size.

7.18 DATUM FEATURE SELECTION PRACTICAL APPLICATION

[Figure 7-43](#) illustrates an assembly of mating parts. Datum features for this assembly are shown in [Figures 7-44](#) and [7-45](#) and were selected based on functional assembly and mating conditions. [Figure 7-44](#) illustrates the pulley and the datum features selected based on the functional interrelationship with the adapter in the assembly. The internal bore on the pulley is selected as the primary datum feature (identified as A) based on the amount of contact it has with the pilot diameter of the adapter. The shoulder has the secondary contact with the adapter, and it is selected as the secondary datum feature (identified as B). The assembly of the pulley to the adapter depends on the clamping of the bolt and washer; a tertiary datum feature is not necessary. [Figure 7-45](#) illustrates the adapter with its datum features and appropriate geometric tolerances based on function. An analysis of the relationship between the adapter and the crankshaft indicates that the shoulder has the most contact with the crankshaft; because the bolt force on the assembly loads the shoulder surface plane into contact with the end of the crankshaft, establishing an initial orientation, it is selected as the primary datum feature (identified as A) for the adapter. Secondary contact is between the pilot on the adapter and the bore on the crankshaft, and therefore the pilot is selected as the secondary datum feature (identified as B) for the adapter. In this example, a tertiary datum feature is unnecessary as the rotation is constrained by the five clearance holes and other features on the part do not need to be controlled for rotation. Selection of datum features in this manner minimizes tolerance accumulation within an assembly and is also representative of actual function.

7.19 SIMULTANEOUS REQUIREMENTS

A simultaneous requirement applies to position and profile tolerances that are located by basic dimensions related to common datum features referenced in the same order of precedence at the same boundary conditions. In a simultaneous requirement, there is no translation or rotation between the datum reference frames of the included geometric tolerances, thus creating a single pattern. [Figures 7-46](#) and [7-47](#) show examples of simultaneous requirements. If such an interrelationship is not required, a notation such as **SEP REQT** should be placed adjacent to each applicable feature control frame. See

Figures 7-48 and 10-54 and para. 10.5.4.2. This principle does not apply to the lower segments of composite feature control frames. See para. 10.5.4.2. If a simultaneous requirement is desired for the lower segments of two or more composite feature control frames, a notation such as **SIM REQ**T shall be placed adjacent to each applicable lower segment of the feature control frames. Simultaneous requirements are not applicable and cannot be invoked by notation on single-segment or multiple-segment feature control frames when the datum references are different, the datum references appear in a different order of precedence, or the applicable material boundaries are different.

7.20 RESTRAINED CONDITION

It may be desirable to restrain a part or assembly to simulate its shape in the installed condition. To invoke a restrained condition, a general note, a flag, or a local note shall be specified or referenced on the drawing or annotated model defining the restraint requirements. See Figures 7-27 and 7-49. When a general note invokes a restrained condition, all dimensions and tolerances apply in the restrained condition unless they are overridden by a “free state” symbol or equivalent method. If a restrained condition is invoked by a flag or local note, only the noted dimensions and tolerances apply in the restrained condition.

7.20.1 Specification of Restraint Magnitude

The allowed or required magnitude of force (clamp load, torque, etc.) or condition used to restrain a part may be one of the following:

- (a) the magnitude necessary to restrain the part on the physical datum feature simulators. See Figure 7-49.
- (b) the magnitude of the load that the part is subjected to in its installed condition.

7.20.2 Location, Direction, Sequence, and Area of Restraint

When applicable, parameters such as the location, direction, sequence, and area of restraint may be shown on the drawing or annotated model, or be specified in another document. If the parameters of restraint are specified in another document, the document shall be noted on the product drawing or annotated model. Additional restraints may not be used.

(a) When datum targets are specified, the restraint load shall be applied over each datum target, normal to the surface at that location and the same size and shape as the datum target UOS. In cases in which restraint applies to a datum target line or area specified on a surface with more than one normal vector, the direction of the restraint load should be specified.

(b) When the entire surface is specified as the datum feature, the restraint load shall be applied over the entire datum feature, normal to the true geometric counterpart and the same size and shape as the datum feature UOS. In cases in which restraint applies to a datum feature with more than one normal vector, the direction of the restraint load should be specified.

7.20.3 Gravity

When the force of gravity is a concern regarding product requirements, the direction of gravity shall be indicated.

7.20.4 Application of “Free State” Symbol

The “free state” symbol may only be applied to tolerances on parts that include one or more restraint notes. Free state variation on restrained parts may be controlled as described in paras. 7.20.4.1 through 7.20.4.5.

7.20.4.1 Specifying Directly Toleranced Dimensions for Features Subject to Free State Variation on a Restrained Part. If a directly toleranced dimension is applied to a feature in the free state on a restrained part, the “free state” symbol, where required, is placed adjacent to the directly toleranced dimension to remove the restrained requirement from the indicated dimension.

7.20.4.2 Specifying Geometric Tolerances on Features Subject to Free State Variation on a Restrained Part. When a geometric tolerance is applied with the “free state” symbol, the tolerance is applicable on that feature with the part in a free state. Where required, the “free state” symbol is placed in the feature control frame, following the tolerance and any modifiers, to remove the restrained requirement for that tolerance. See Figures 6-22 and 8-14.

7.20.4.3 Specifying a Free State Datum Reference(s) on a Restrained Part. A geometric tolerance applied to a restrained part or assembly may require one or more free state (unrestrained) datum references. Unrestrained datum features are designated by the “free state” symbol applied to a datum feature referenced in the feature control frame following any other modifying symbols. See Figures 7-49 through 7-51. For overconstrained datum reference frames on a produced part, the datum features or datum targets referenced as free state are not required to contact the physical datum feature simulator when they are in the free state.

7.20.4.4 Restraining Parts Using Features of Size. It may be necessary to use multiple features of size to establish a datum reference frame when a restrained requirement is invoked. For the datum features to comply with the physical datum feature simulators, forces may be applied

in accordance with the specified restraint requirement to flex or deform the part. See [Figure 7-52](#).

NOTE: The position tolerance shown in [Figure 7-52](#) for datum feature B (pattern of four holes) is not used to determine the free state location of the holes. It is used to establish the MMB simulators that are to restrain the part to simulate the installed condition.

7.20.4.5 Contacting Physical Datum Feature Simulators. When restraint is applied, all restrained nonsize datum features shall contact the physical datum feature simulators, UOS. Features of size referenced at MMB are not required to make contact with the simulator.

7.21 DATUM REFERENCE FRAME IDENTIFICATION

When a datum reference frame has been properly established and it is considered necessary to illustrate the coordinate system of a datum reference frame, the axes of the coordinate system may be labeled on the orthographic views to show the translational degrees of freedom x , y , and z . See [Figures 7-2](#), [7-6](#), [7-13](#), and [7-53](#). On the model, each datum reference frame shall be associated with a corresponding coordinate system per ASME Y14.41.

(a) *Orthographic View Requirements.* When multiple datum reference frames exist and it is desirable to label the axes of the coordinate system (X , Y , and Z), any labeled axes shall include a reference to the associated datum reference frame. On the orthographic view, the X -, Y -, and Z -axes for the three datum reference frames shall be identified by the notation **[A,B,C]**, **[A,B,D]**, and **[A,B,E]**. These labels represent the datum features (without modifiers) for each datum reference frame, and follow the X , Y , and Z identification letters. See [Figure 7-54](#).

(b) *Use of Common Datum Features.* When common datum features are used to identify a datum within a datum reference frame, the relevant common datum feature letters shall be separated by a hyphen as in **[F-D,B,C]**.

(c) *Model Requirements.* Each datum reference frame-to-coordinate system relationship shall be clearly presented. When a datum reference frame is labeled, the label shall take the form of **DRF_XXX** (underscore required), where the datum letters of the datum reference frame are used in place of **XXX**.

7.22 CUSTOMIZED DATUM REFERENCE FRAME CONSTRUCTION

To limit the degrees of freedom constrained by datum features referenced in an order of precedence, a customized datum reference frame may be invoked. When applying the customized datum reference frame, the following requirements govern the constraint on each datum feature reference:

(a) Where orthographic views are used, the rectangular coordinate axes shall be labeled in at least two views on the drawing. See [Figures 7-55](#) and [7-56](#). In a model, the axes only need to be labeled once for each datum reference frame.

(b) The degree(s) of freedom to be constrained by each datum feature referenced in the feature control frame shall be explicitly stated by placing the designated degree of freedom to be constrained in lowercase letter(s) “[x,y,z,u,v,w]” in brackets following each datum feature reference and any applicable modifier (s). See [Figures 7-56](#) and [7-57](#).

NOTE: Customized datum reference frames shall not be used with composite tolerances. Where a customized datum reference frame is needed, one or more single-segment feature control frames shall be used.

7.23 APPLICATION OF A CUSTOMIZED DATUM REFERENCE FRAME

In [Figure 7-55](#), the conical primary datum feature A constrains five degrees of freedom, including translation in z . The origin of the datum reference frame to locate the 6-dia. hole is from the apex of the conical true geometric counterpart. In some applications, it may be necessary to customize the datum reference frame. The following are examples of applications of customized datum reference frames:

(a) In [Figure 7-56](#), the design intent is that the primary datum feature A constrains four degrees of freedom, excluding translation in z . Secondary datum feature B is a thrust face and, when customized, constrains the translational degree of freedom (z). The 6-dia. hole is located to the conical feature with translation z omitted. Secondary datum feature B constrains translation in z . In this example, the declared degrees of constraint for datum feature A are x , y , u , and v . The declared degree of constraint for datum feature B is z .

(b) In [Figure 7-57](#), datum feature B would normally constrain two translational degrees of freedom, x and y , and one rotational degree of freedom, w . See [Figure 7-3](#), illustration (f). The purpose of the square hole is to transfer torque but not to orient the part. Therefore, the design intent is that datum feature B restrains two translational degrees of freedom but not the rotational degree of freedom. In the position tolerance for the three holes, datum feature A constrains three degrees of freedom, z , u , and v . Even though datum feature B would normally constrain the three remaining degrees of freedom, using the customized datum reference frame constraint requirements, datum feature B constrains only two translational degrees of freedom, x and y . Datum feature C, then, constrains the remaining degree of rotational freedom, w .

7.24 DATUM TARGETS

Datum targets may be used in establishing a datum reference frame. Because of inherent irregularities, the entire surface of some features cannot be effectively used to establish a datum. Examples are nonplanar or uneven surfaces produced by casting, forging, or molding; surfaces of weldments; and thin-section surfaces subject to bowing, warping, or other inherent or induced distortions. Where the entire surface is not used to establish a datum, datum targets are used in establishing a datum reference frame. Datum targets and datum features (as described earlier) may be combined to establish a datum reference frame. Where datum feature reference is made to datum targets applied on a feature of size, RMB is applicable unless the datum feature reference is otherwise modified.

7.24.1 Establishing a Center Plane From Datum Targets

Figure 7-58 is an example of a center plane established by a V-shaped true geometric counterpart established from two datum target lines. In the orthographic view, datum targets B1 and B2 are located relative to datum targets A1 and A2 with a basic dimension and are shown as datum target lines. If a datum target plane V-shaped true geometric counterpart is required, B1 and B2 would only be shown in the top view. On the model, the V-shaped simulator is represented by supplemental geometry tangent to the cylindrical feature, and the datum target is attached by a leader. For clarification, the direction of movement may be indicated by the addition of a represented line element as described in ASME Y14.41.

7.24.2 “Movable Datum Target” Symbol

The “movable datum target” symbol may be used to indicate movement of the datum target’s true geometric counterpart. Where datum targets establish a center point, axis, or center plane and RMB is applicable, the true geometric counterpart moves normal to the true profile, and the “movable datum target” symbol, though not required, may be used for clarity. Where the true geometric counterpart is not normal to the true profile, the “movable datum target” symbol shall be used, and the direction of the movement shall be defined as described in (a) through (c) below. See Figure 7-58. For an example of where the true geometric counterpart moves along an axis, see Figure 7-59.

(a) For orthographic views on engineering drawings, the movement may be indicated by the addition of a line indicating the direction of movement. The line element is placed at the point of contact for a datum target point, along the line for a datum target line, or within the area for a datum target area. The movement is along the represented line element. The line element

shall be specified with one or more basic angles. See Figure 7-58, illustration (a).

(b) Alternatively, for drawings that include X -, Y -, and Z -axes to represent the datum reference frame(s), the direction of movement may be indicated using a unit vector designation consisting of i , j , k components (corresponding to the X -, Y -, and Z -axes of the coordinate system), placed in brackets and adjacent to the “movable datum target” symbol. The vector direction is toward the surface of each datum feature. See Figure 7-58, illustration (b). The vector notation shall be shown in at least one view where the target is shown. For drawings that include more than one datum reference frame, the particular datum reference frame to which the i , j , k components are related shall be specified by placing the applicable datum feature letters within square brackets following the closing bracket that contains the i , j , k components (such as “[i , j , k]” or “[A,B,C]”).

(c) For a model, the direction of movement shall be indicated by the addition of a represented line element to indicate the direction of movement. The line element shall be placed on the outside of the material. One end of the line element shall terminate at the point of contact for a datum target point, at a point on the line for a datum target line, or at a point within the area for a datum target area. The movement is along the represented line element. See Figure 7-58, illustration (c) and ASME Y14.41.

7.24.3 Datum Target Dimensions

Where applicable, the location and size of datum targets should be defined with either basic or directly toleranced dimensions. If basic dimensions are used, established tooling or gaging tolerances apply. Figure 7-60 illustrates a part where datum targets are located by means of basic dimensions.

NOTE: For information on tolerancing physical datum feature simulators and their interrelationships between the simulators, see ASME Y14.43.

7.24.4 Datum Planes Established by Datum Targets

A primary datum plane is established by at least three target points not on a straight line. See Figure 7-60. A secondary datum plane is usually established by two targets. A tertiary datum plane is usually established by one target. A combination of target points, lines, and areas may be used. See Figure 7-60. For stepped surfaces, the datum plane should contain at least one of the datum targets. Some features, such as curved or contoured surfaces, may require datum planes that are completely offset from the datum targets. See Figure 7-53.

7.24.5 Stepped Surfaces

A datum plane may be established by targets located on stepped surfaces, as in [Figures 7-58](#) and [7-60](#). The basic dimension defines the offset between the datum targets.

7.24.6 Primary Datum Axis

Two sets of three equally spaced datum targets may be used to establish a datum axis for a primary datum feature. See [Figures 7-61](#) and [7-62](#). The two datum target sets are spaced as far apart as practical and dimensioned from the secondary datum feature where needed. Where RMB is applicable, a centering procedure used to establish the datum axis has two sets of three equally spaced contacting datum target simulators capable of moving radially at an equal rate from a common axis. To ensure repeatability of the location of the three datum target points, a tertiary datum feature may be necessary. For the MMB, the centering procedure used to establish the datum axis has two sets of three equally spaced datum target simulators set at a fixed radial distance based on the MMB. Where two cylindrical datum features of different diameters are used to establish a datum axis, as in [Figure 7-62](#), each datum feature is identified with a different letter.

7.24.7 Circular and Cylindrical Targets

Circular target lines and cylindrical target areas may be used to establish a datum axis on round features. See [Figure 7-63](#).

7.24.8 Secondary Datum Axis

For a secondary datum feature, a set of three equally spaced targets may be used to establish a datum axis. See [Figure 7-64](#). In this example, the datum targets and the contacting true geometric counterparts are oriented relative to the datum reference frame. Where RMB is applicable, a typical centering method used to establish the datum axis has a set of three equally spaced contacting true geometric counterparts capable of moving radially

at an equal rate from a common axis that is perpendicular to the primary datum plane. Where MMB is specified, the centering method used to establish the datum axis has a set of three equally spaced features set at a fixed radial distance based on the MMB.

7.24.9 Datums Established From Complex or Irregular Surfaces

Datum targets may be used to establish a datum from a complex or irregular surface. When a datum target area or datum target line is shown on a nonplanar surface, the shape of the datum target's true geometric counterpart is the same as the basic shape of the surface. In [Figure 7-49](#), the datum target area's true geometric counterparts for A1 through A4 are the same as the basic contour of the part surface. Where a datum reference frame has been properly established but its planes are unclear, the datum reference frame coordinate axes may be labeled to appropriate extension or center lines as needed. See [Figure 7-53](#). The datum feature symbol should be attached only to identifiable datum features. Where datums are established by targets on complex or irregular surfaces, the datum may be identified by a note such as **DATUM AXIS A** or **DATUM PLANE A**.

7.24.10 Datum Features Established From Datum Targets With Fewer Than Three Mutually Perpendicular Planes

When using datum features defined by datum targets in a feature control frame established by fewer than three mutually perpendicular planes, the datums that are the basis for the datum reference frame shall be referenced. See [Figure 9-16](#). The targets that provide definition for the datums referenced in the feature control frame shall be specified in a note, such as **WHERE ONLY DATUM FEATURE A IS REFERENCED, DATUM FEATURES B AND C ARE INVOKED ONLY TO RELATE THE TARGETS THAT ESTABLISH DATUM A**.

Figure 7-1 Datum Reference Frame

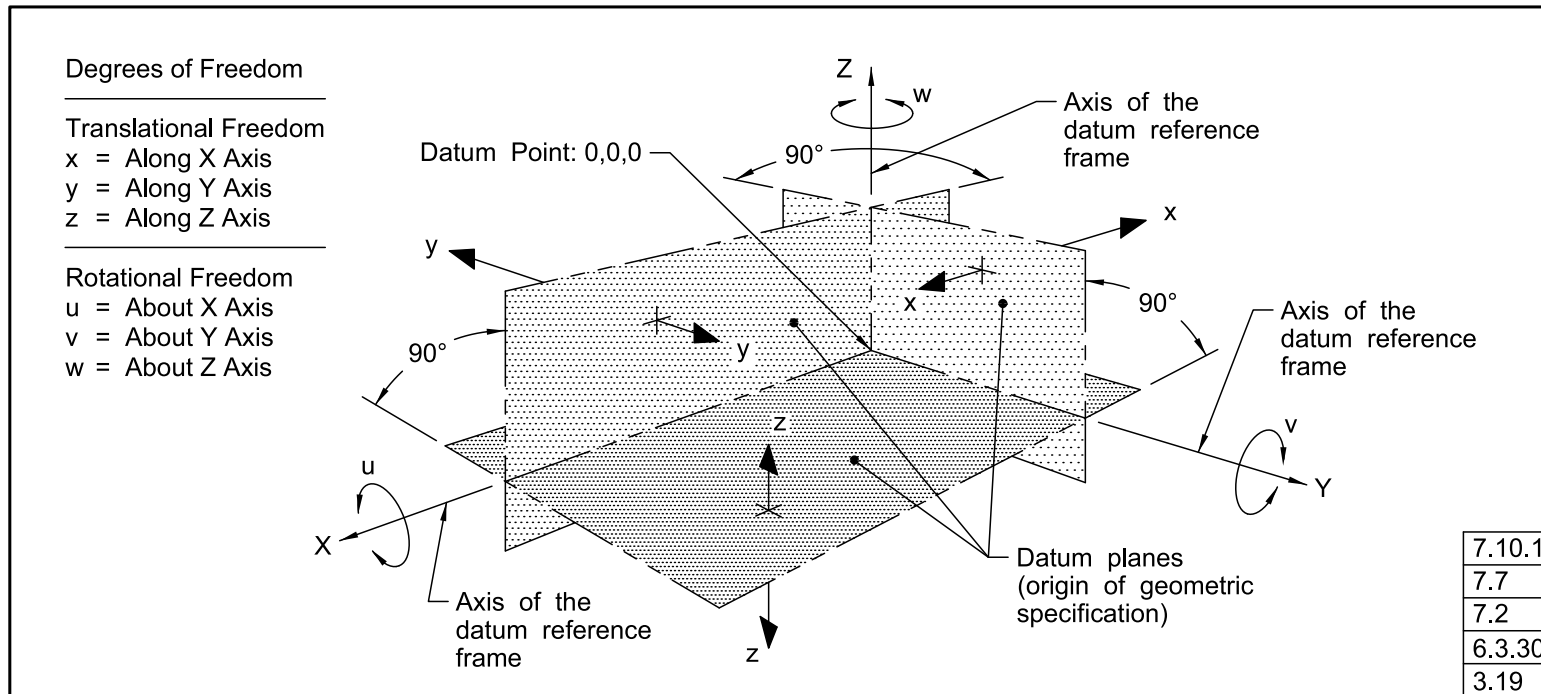

Figure 7-2 Sequence of Datum Features Relates Part to Datum Reference Frame

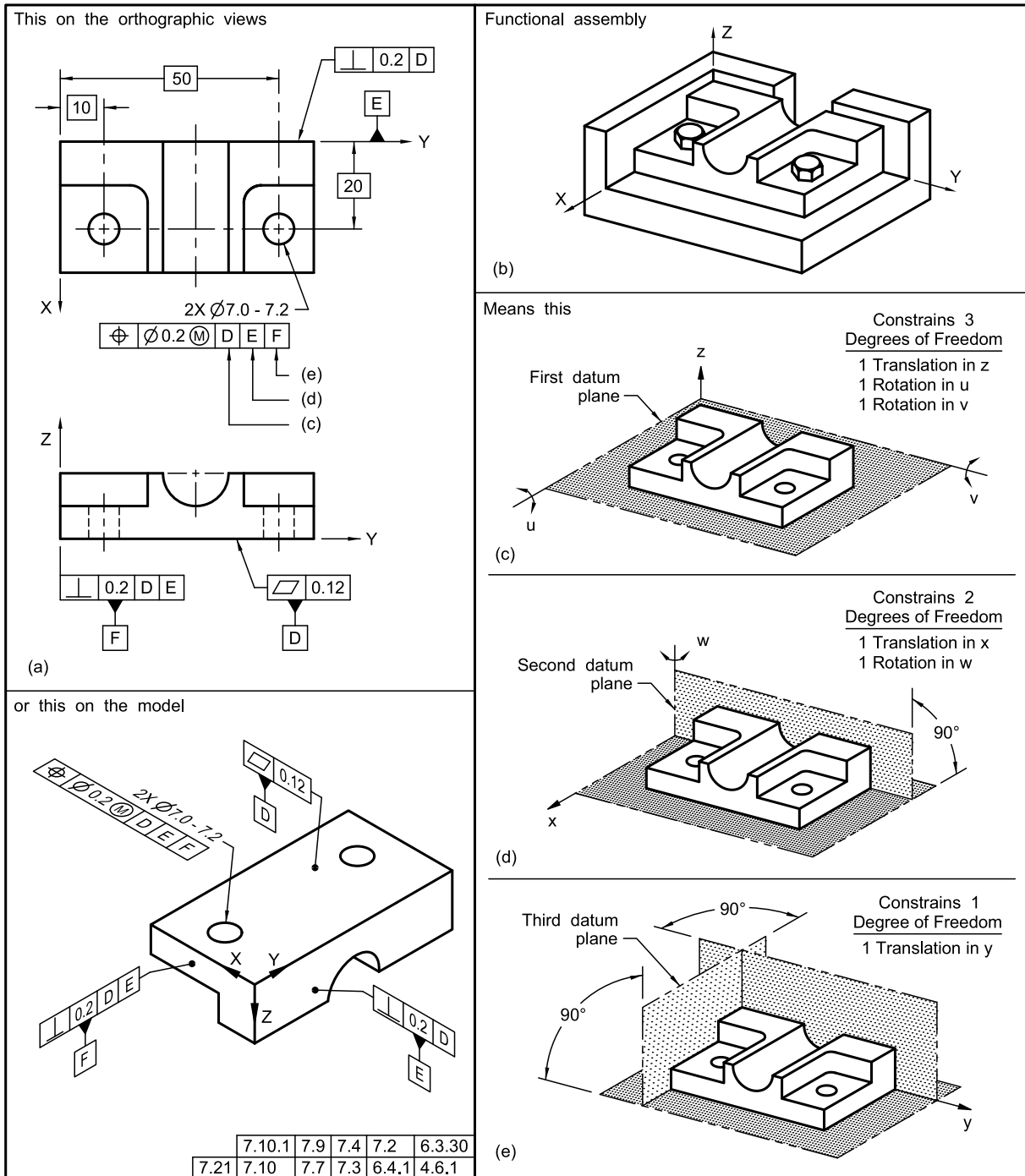
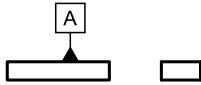
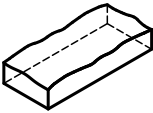
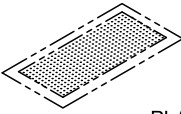
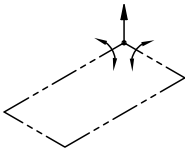
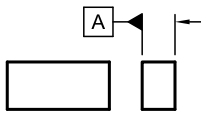
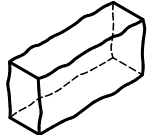
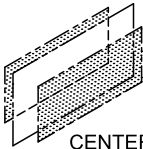
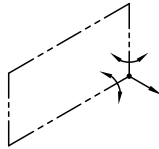
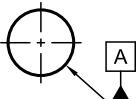



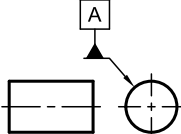
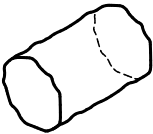
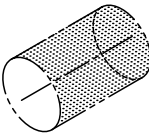

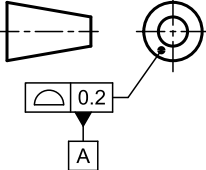
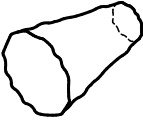
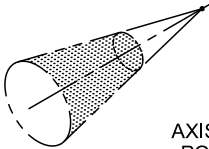
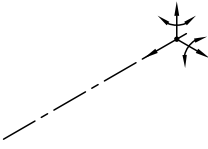
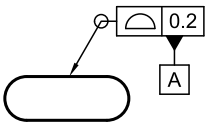
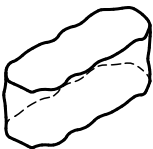
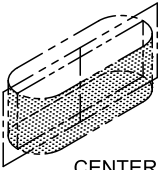
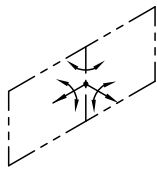
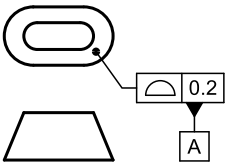
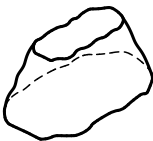
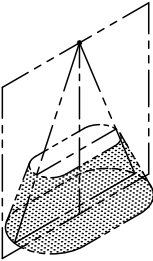
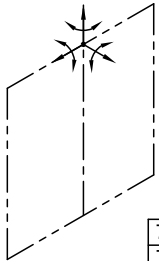

Figure 7-3 Constrained Degrees of Freedom for Primary Datum Features

FEATURE TYPE	ON THE DRAWING	DATUM FEATURE	DATUM AND TRUE GEOMETRIC COUNTERPART	DATUM AND CONSTRAINING DEGREES OF FREEDOM
PLANAR (a)			 PLANE	
WIDTH (b)			 CENTER PLANE	
SPHERICAL (c)			 POINT	
CYLINDRICAL (d)			 AXIS	
CONICAL (e)			 AXIS & POINT	
LINEAR EXTRUDED SHAPE (f)			 AXIS & CENTER PLANE	
COMPLEX (g)			 AXIS, POINT, & CENTER PLANE	

7.23
7.11.4
7.3

Figure 7-4 Part Where Rotational Constraint Is Important

This on the orthographic views

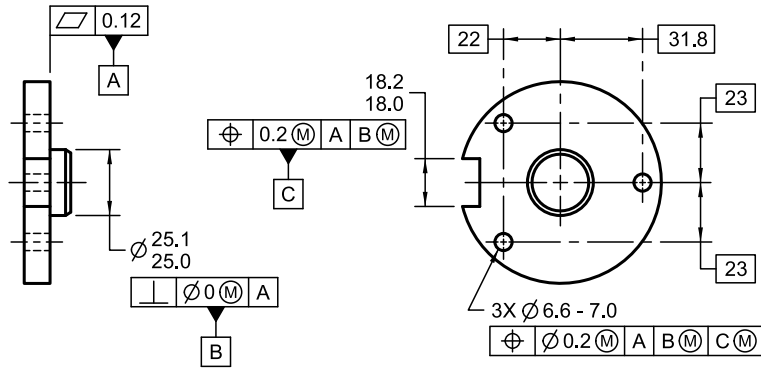

or this on the model

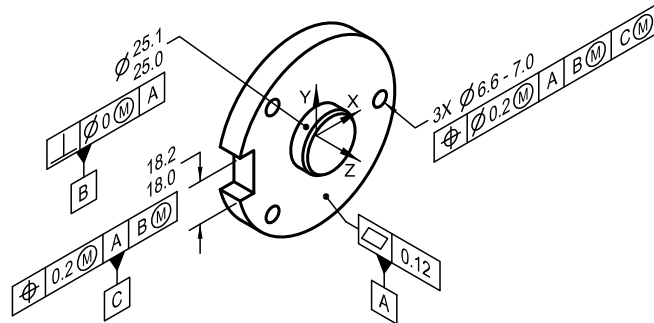

7.10.4
7.9
7.8
7.7
7.4
6.3.5

Application

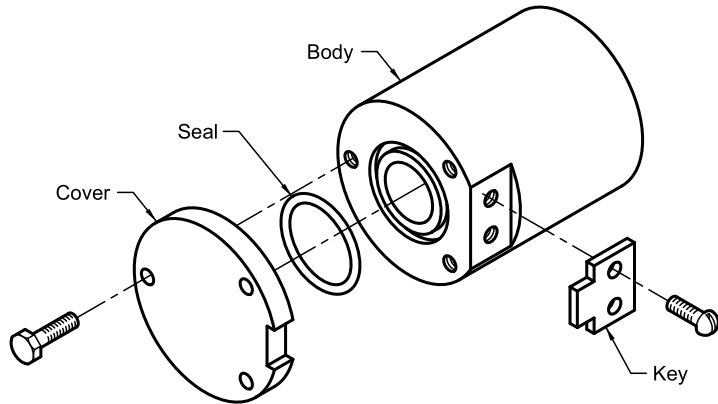

Figure 7-5 Development of a Datum Reference Frame for the Part in Figure 7-4

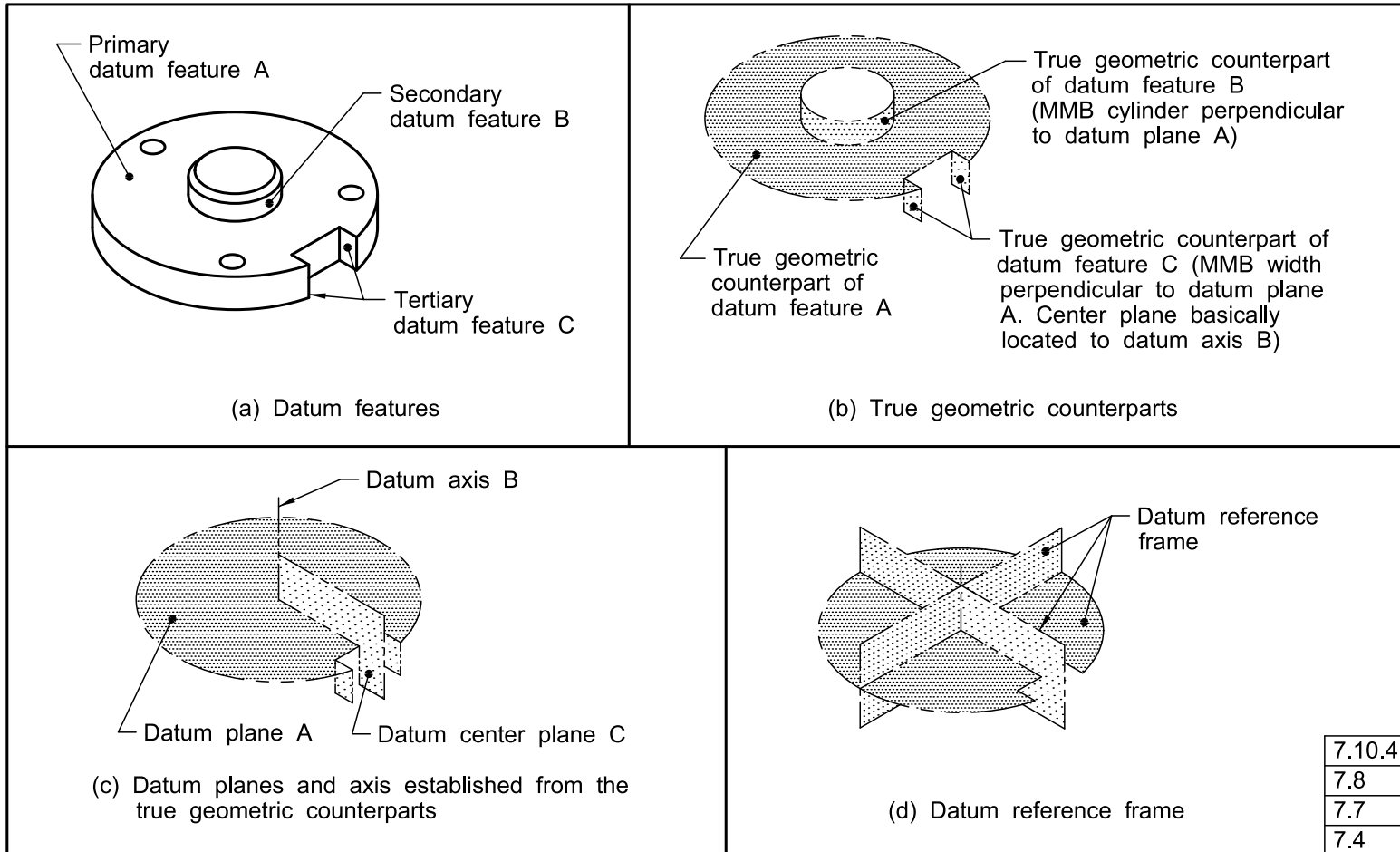
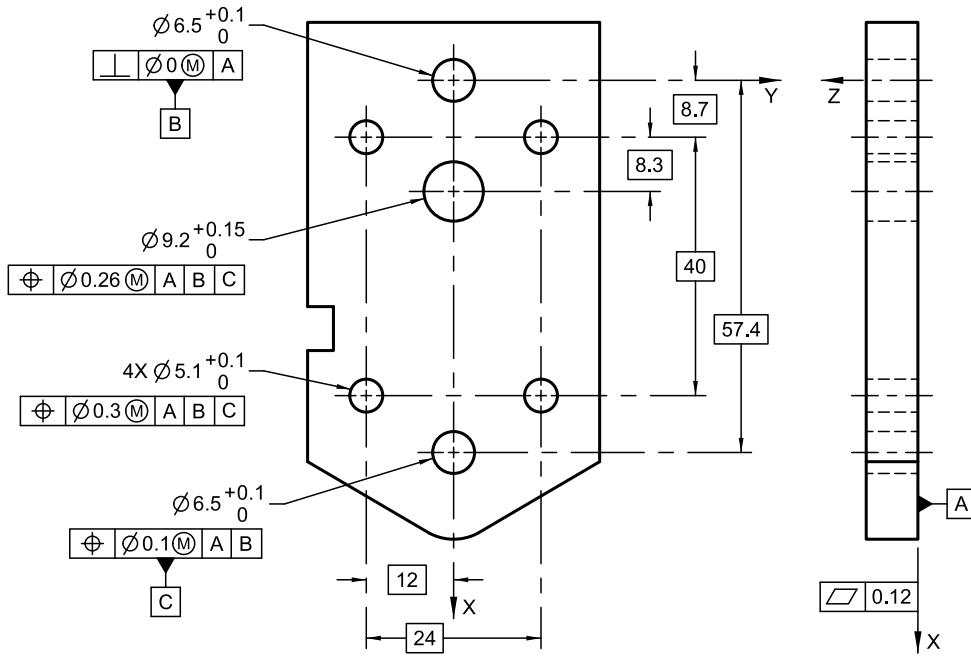
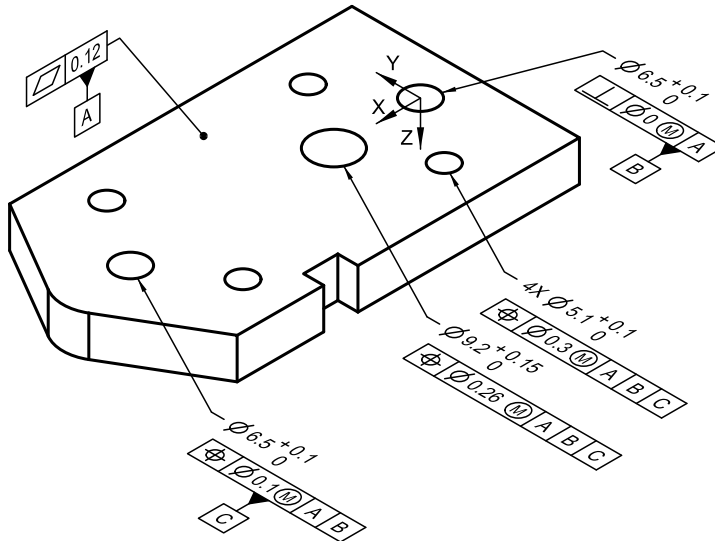

Figure 7-6 Development of a Datum Reference Frame

This on the orthographic view



or this on the model



7.21
7.11.4
7.10.4
7.5.2
7.4

Figure 7-6 Development of a Datum Reference Frame (Cont'd)

Means this

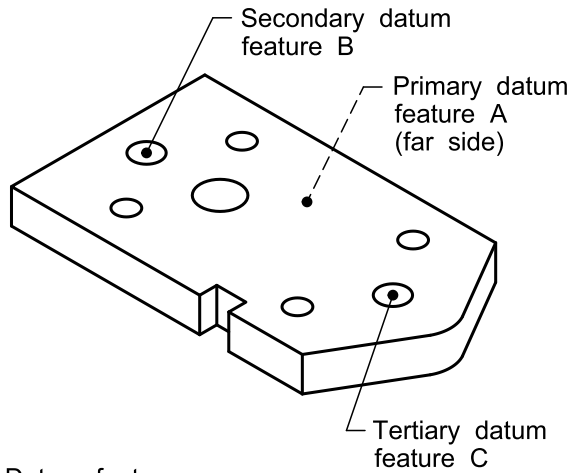

(a) Datum features

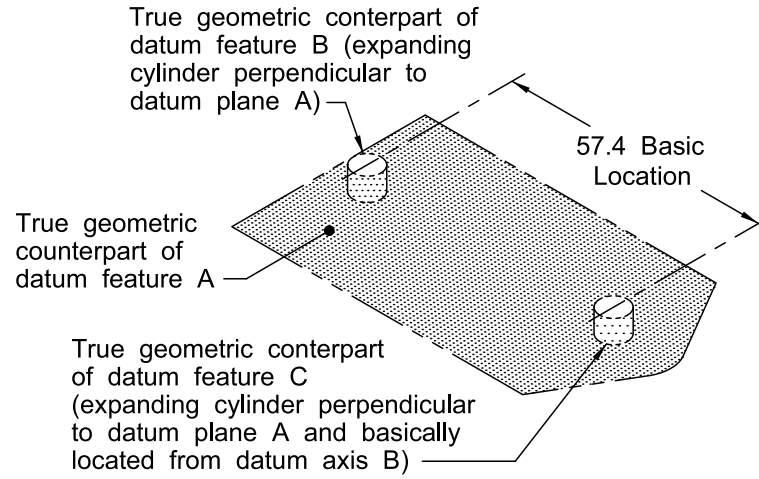

(b) True geometric counterparts

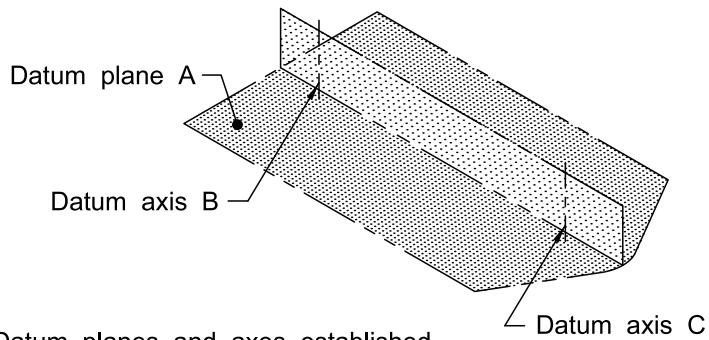

(c) Datum planes and axes established from the true geometric counterparts

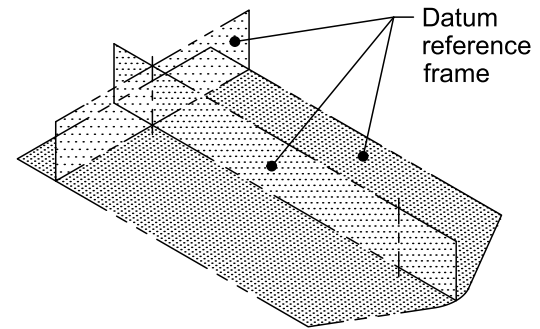

(d) Datum reference frame

Figure 7-7 Datum Plane Establishment

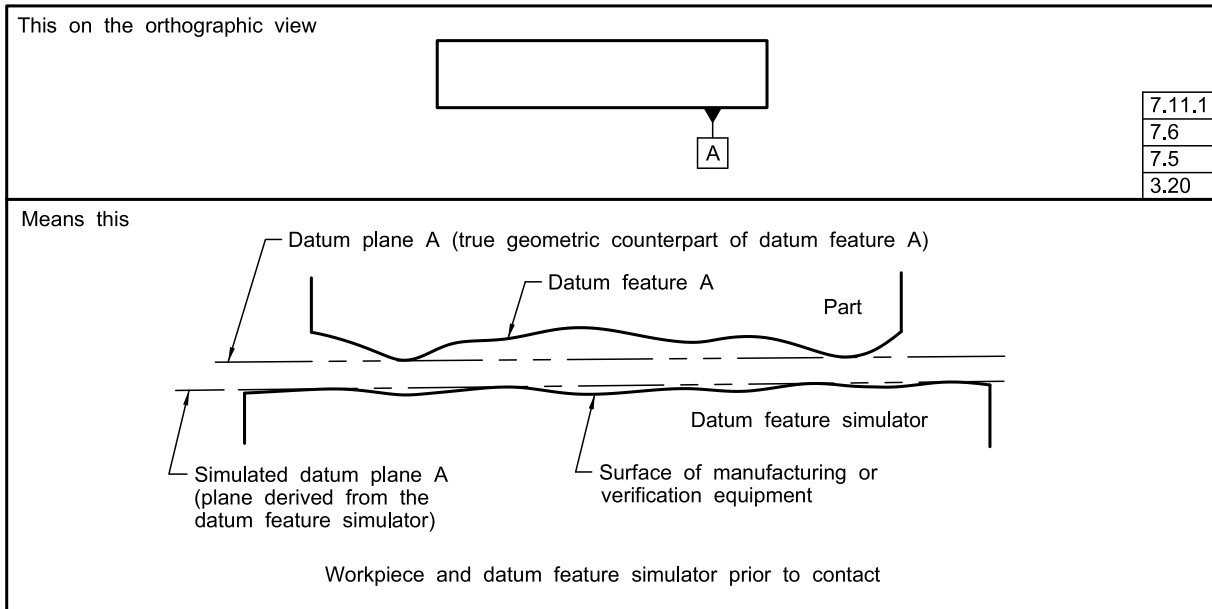

Figure 7-8 Establishment of Datums for Primary External Cylindrical Datum Feature RMB

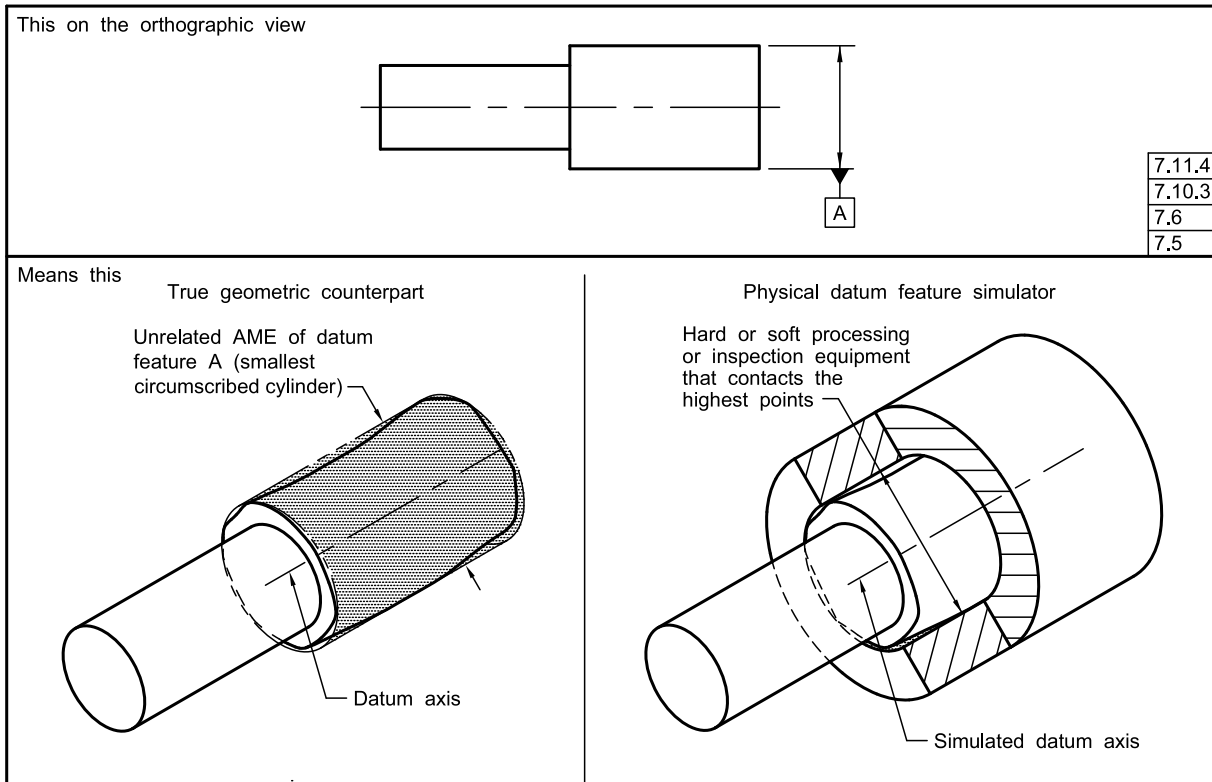

Figure 7-9 Establishment of Datums for Primary Internal Cylindrical Datum Feature RMB

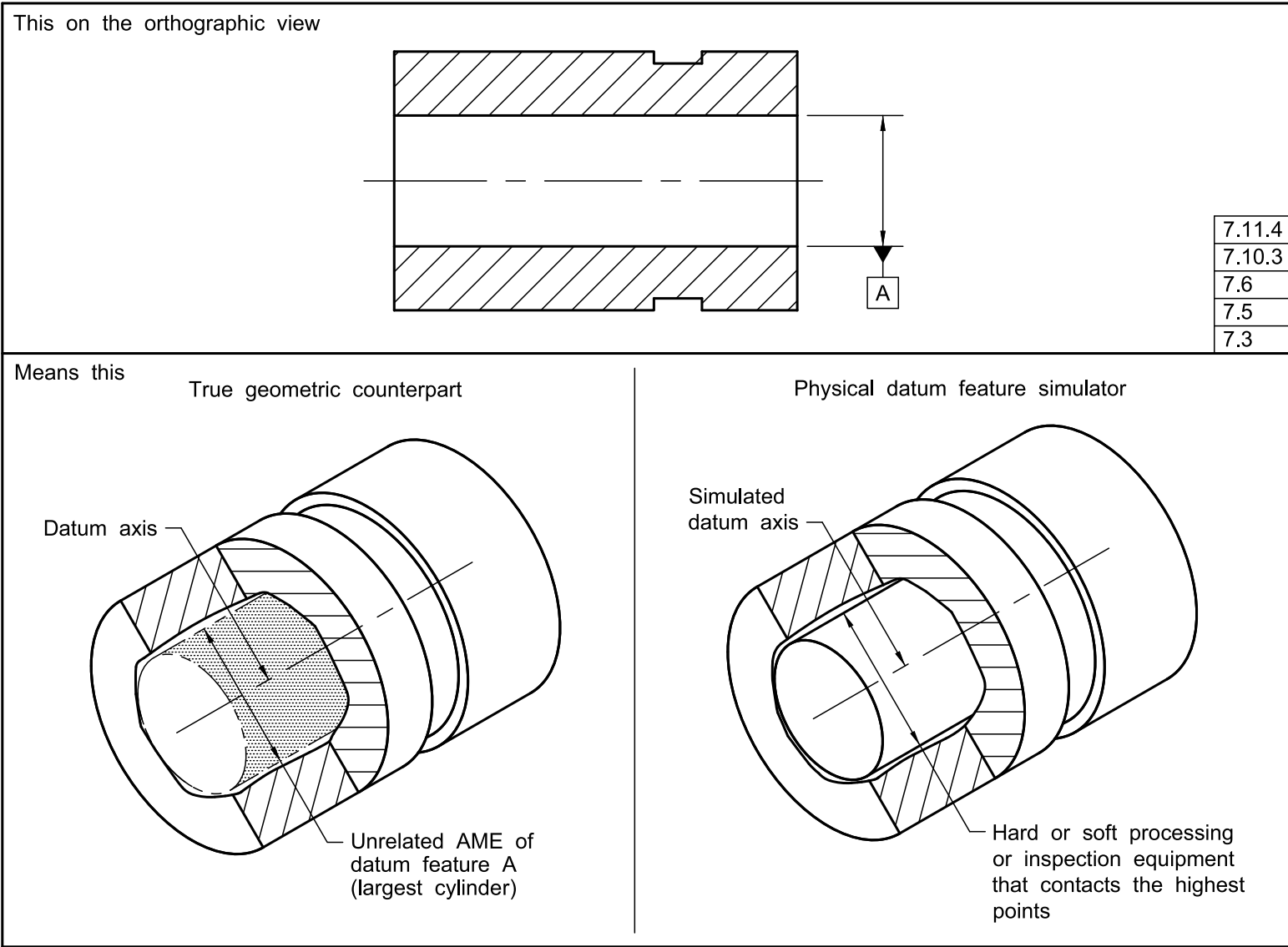
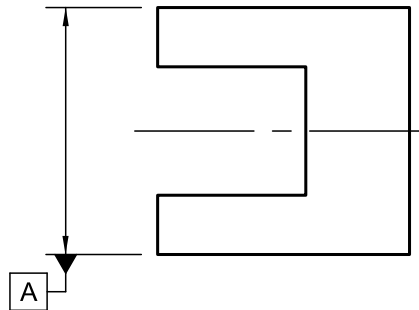

Figure 7-10 Establishment of Datums for Primary External Datum Width Feature RMB

This on the orthographic view



7.11.4
7.5

Means this

True geometric counterpart

Unrelated AME of datum feature A (parallel planes at minimum separation)

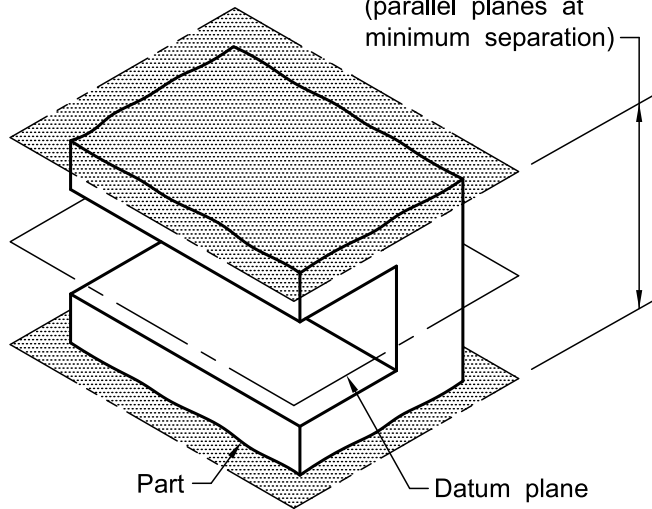

Physical datum feature simulator

Hard or soft processing or inspection equipment that contacts the highest points

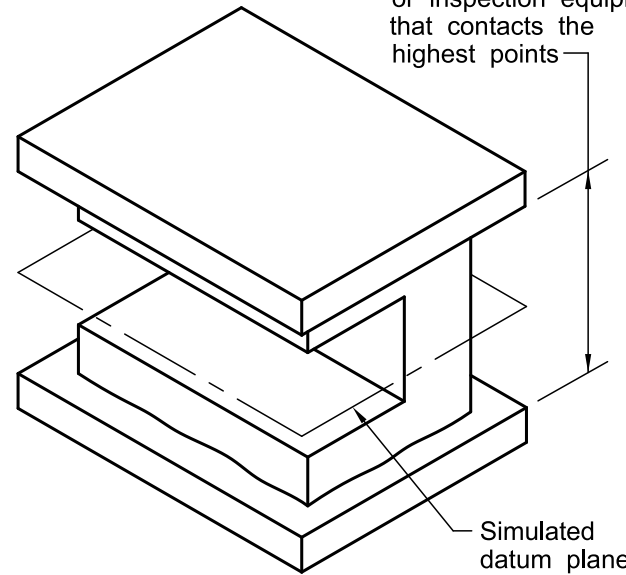
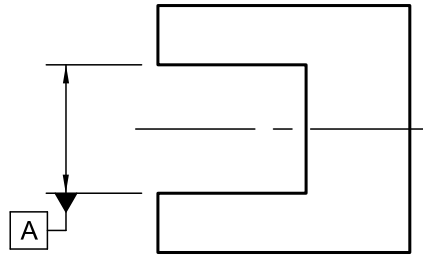

Figure 7-11 Establishment of Datums for Primary Internal Datum Width Feature RMB

This on the orthographic view



7.11.4
7.5

Means this

True geometric counterpart

Unrelated AME of datum feature A (parallel planes at maximum separation)

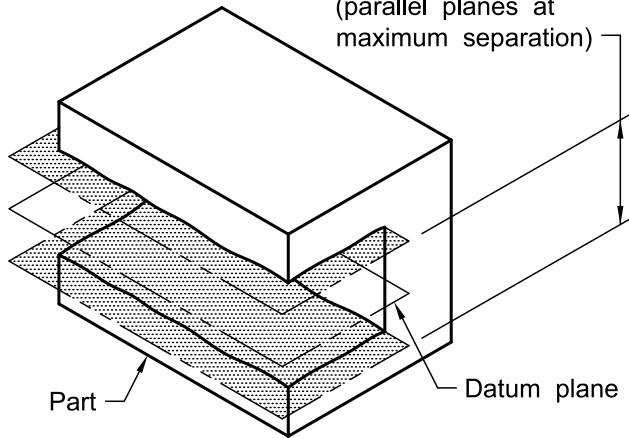

Physical datum feature simulator

Hard or soft processing or inspection equipment that contacts the highest points

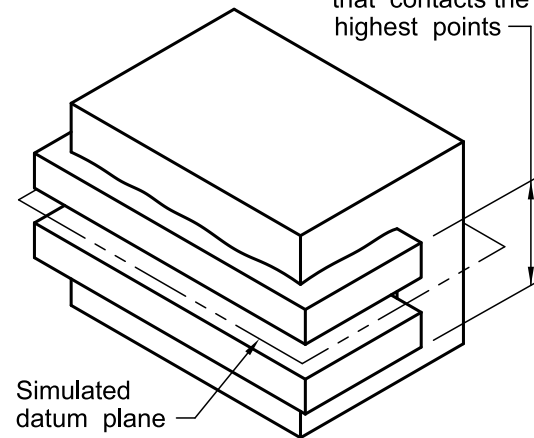

Figure 7-12 Development of a Datum Reference Frame With Translation Modifier

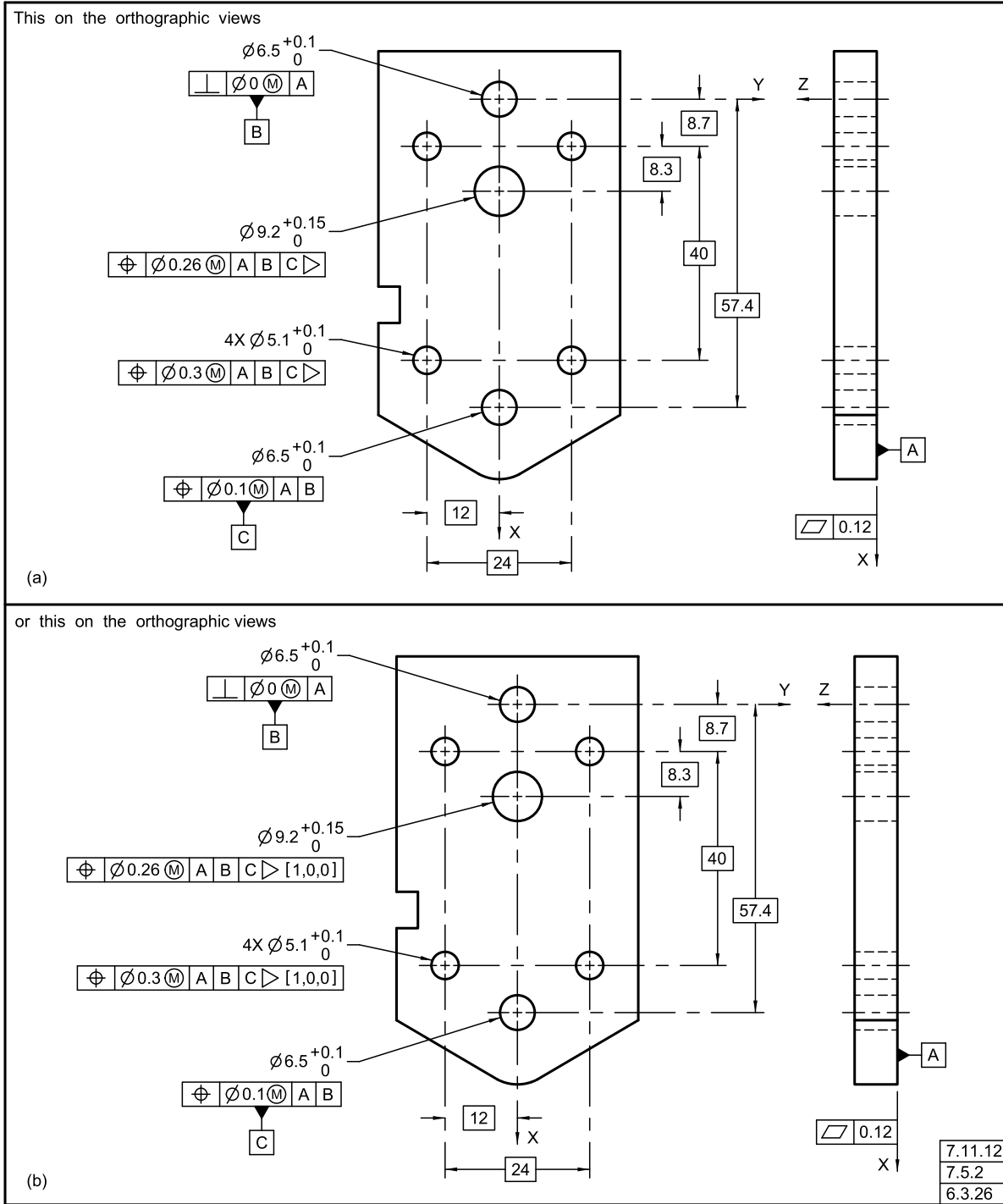
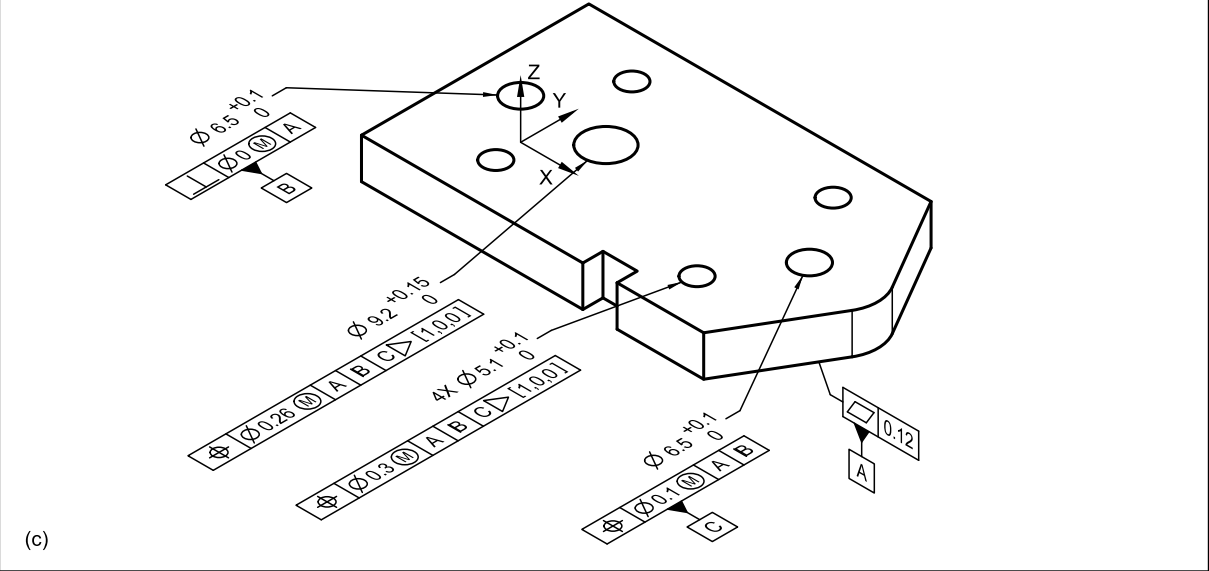

Figure 7-12 Development of a Datum Reference Frame With Translation Modifier (Cont'd)

or this on the model



(c)

Means this

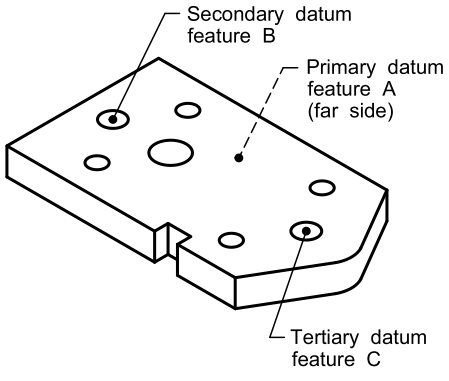

(d) Datum features

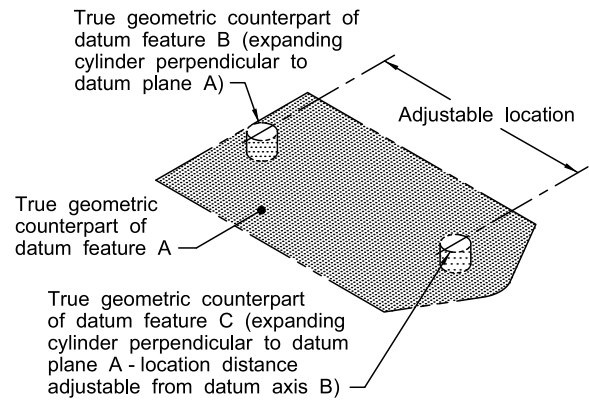

(e) True geometric counterparts

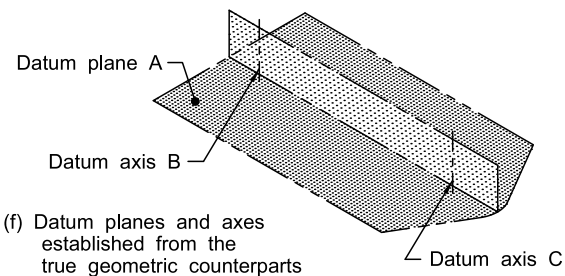

(f) Datum planes and axes established from the true geometric counterparts

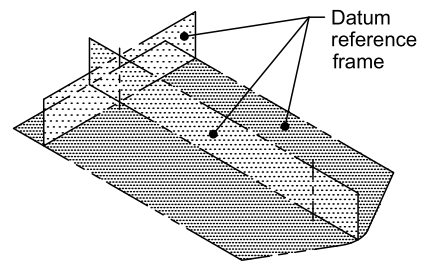

(g) Datum reference frame

Figure 7-13 Inclined Datum Feature

This on the orthographic view

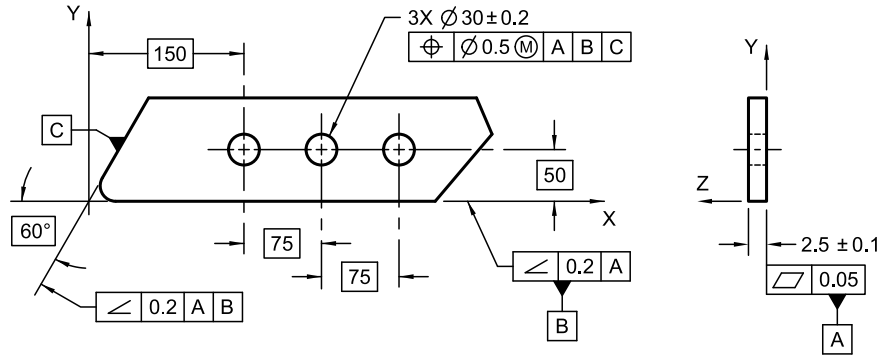

or this on the model

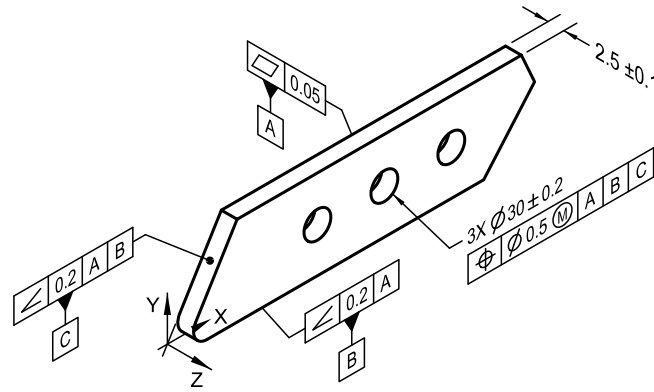

7.21
7.10.2
7.7

Means this

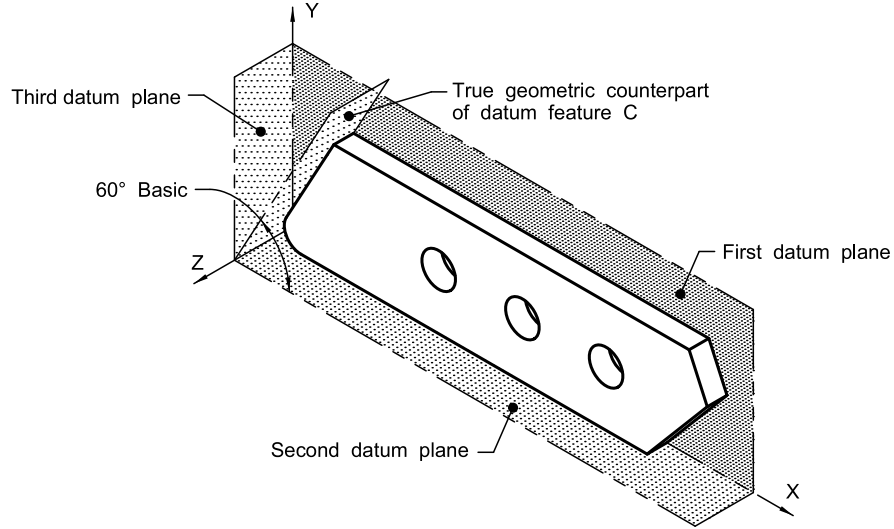

Figure 7-14 Part With Cylindrical Datum Feature

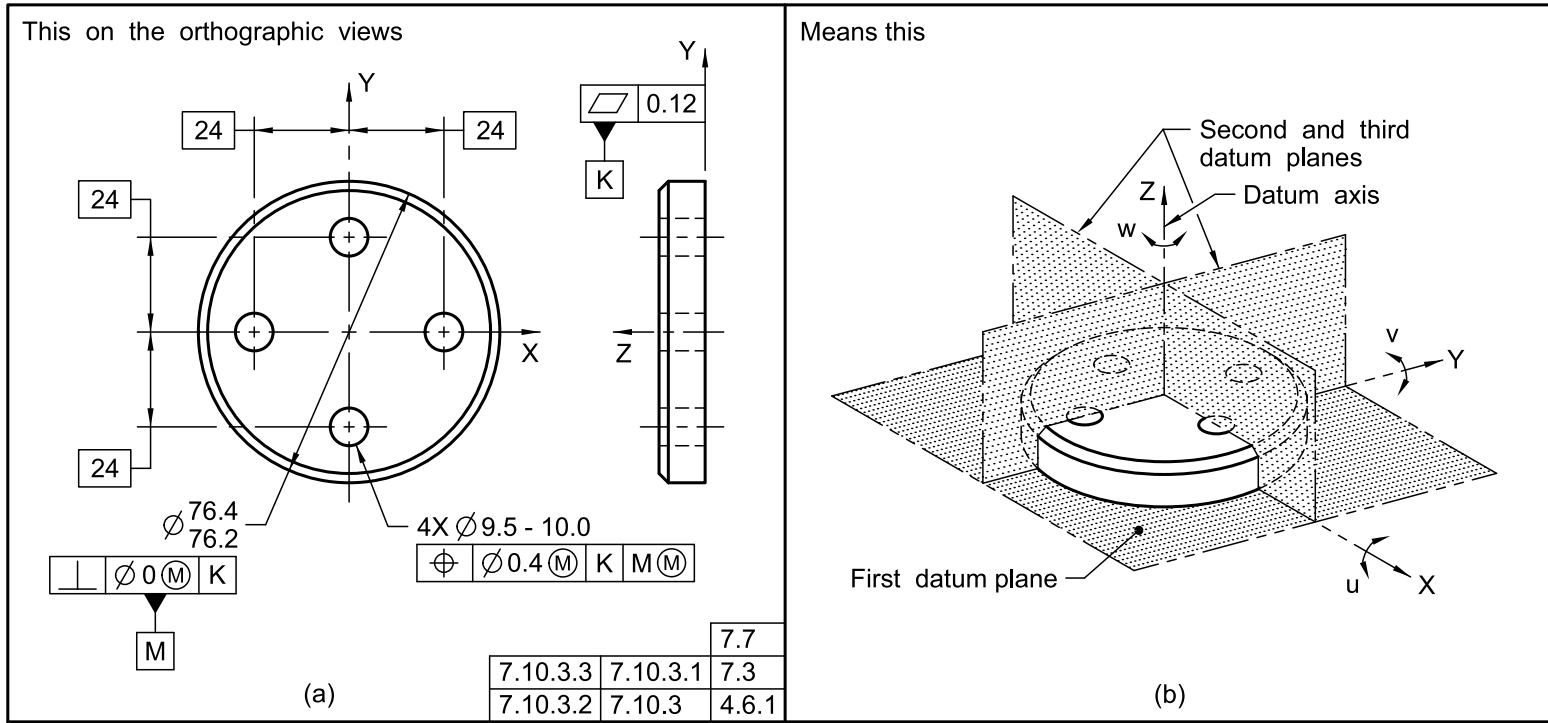

Figure 7-15 Multiple Datum Reference Frames and Their Interrelationships

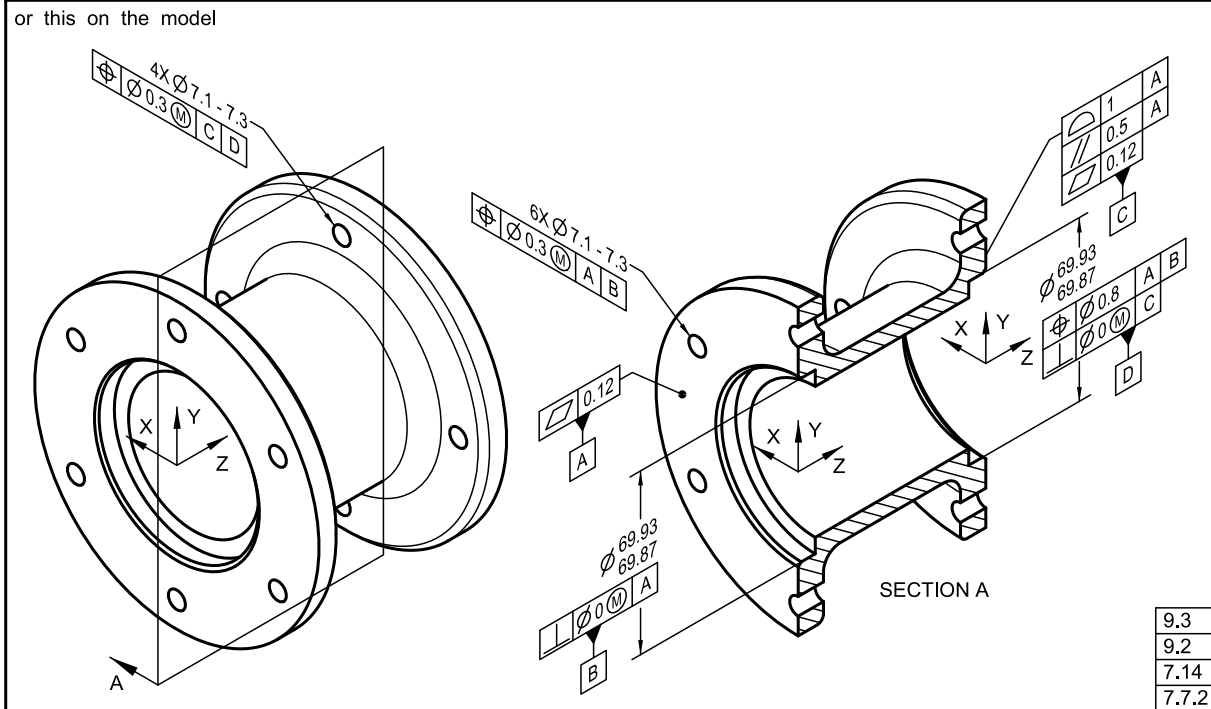
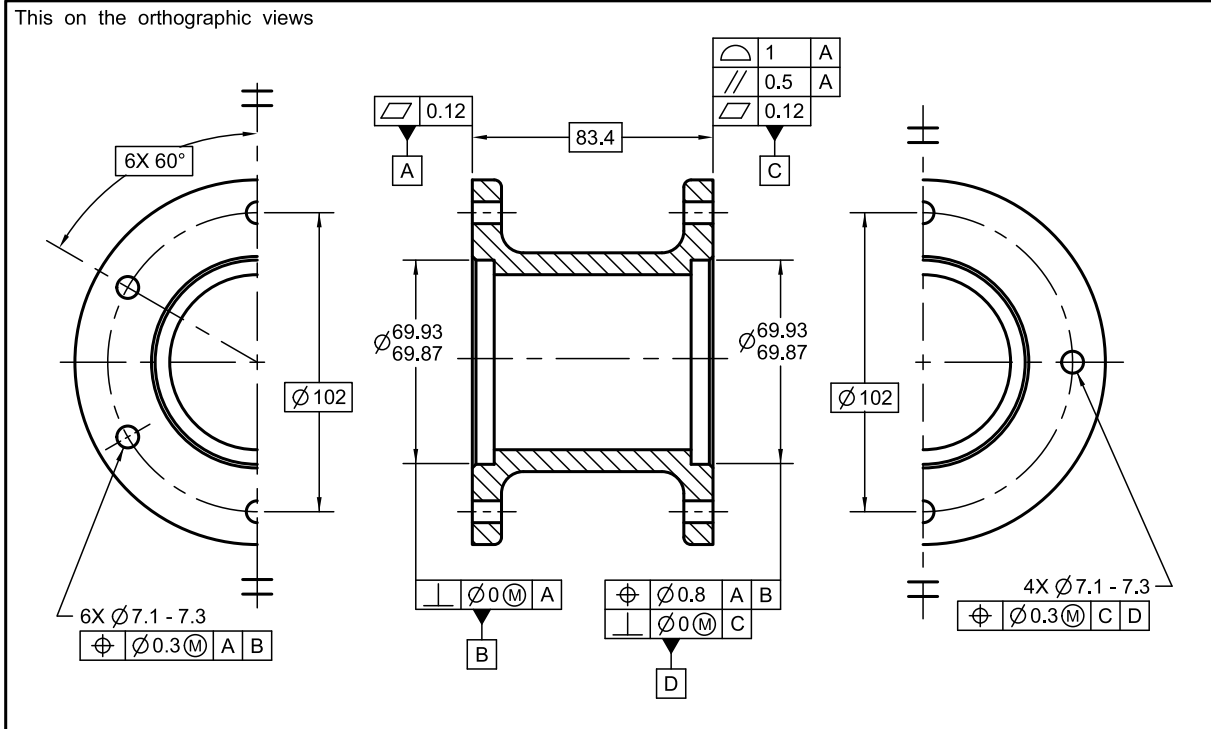
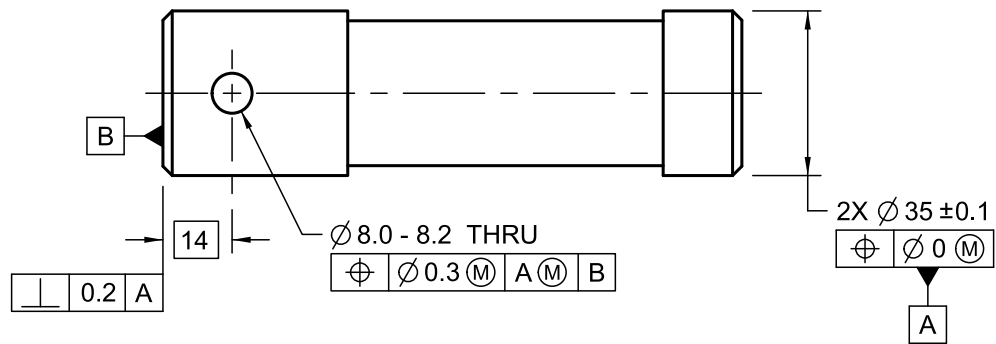

Figure 7-16 Two Coaxial Datum Features, Single Datum Axis

This on the orthographic view



7.12.2
7.11.11
7.9

Means this

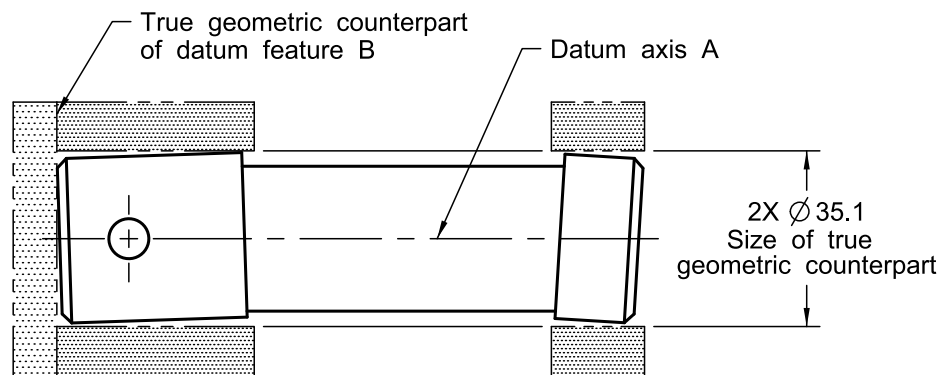
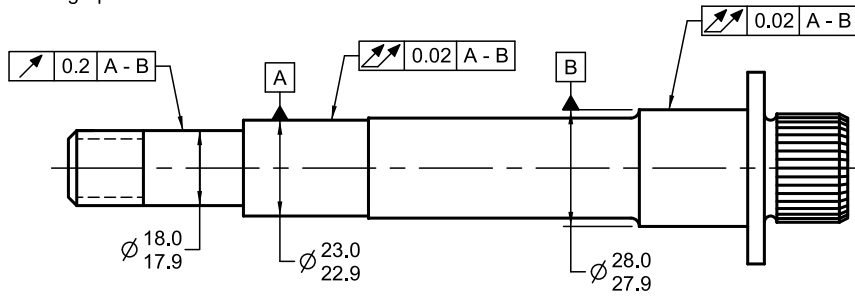
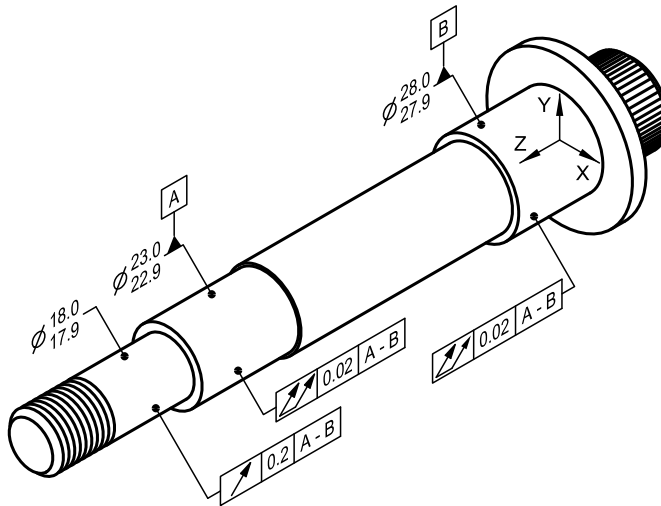

Figure 7-17 Two Datum Features RMB, Single Datum Axis

This on the orthographic view



or this on the model



7.12.4
7.12.2
7.9

Means this

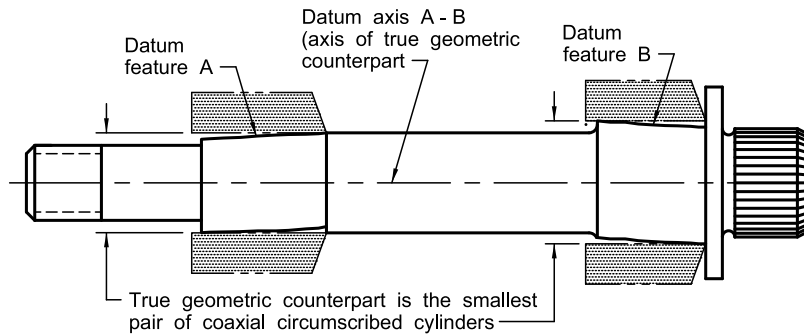

Figure 7-18 Hole Pattern Identified as Datum Feature

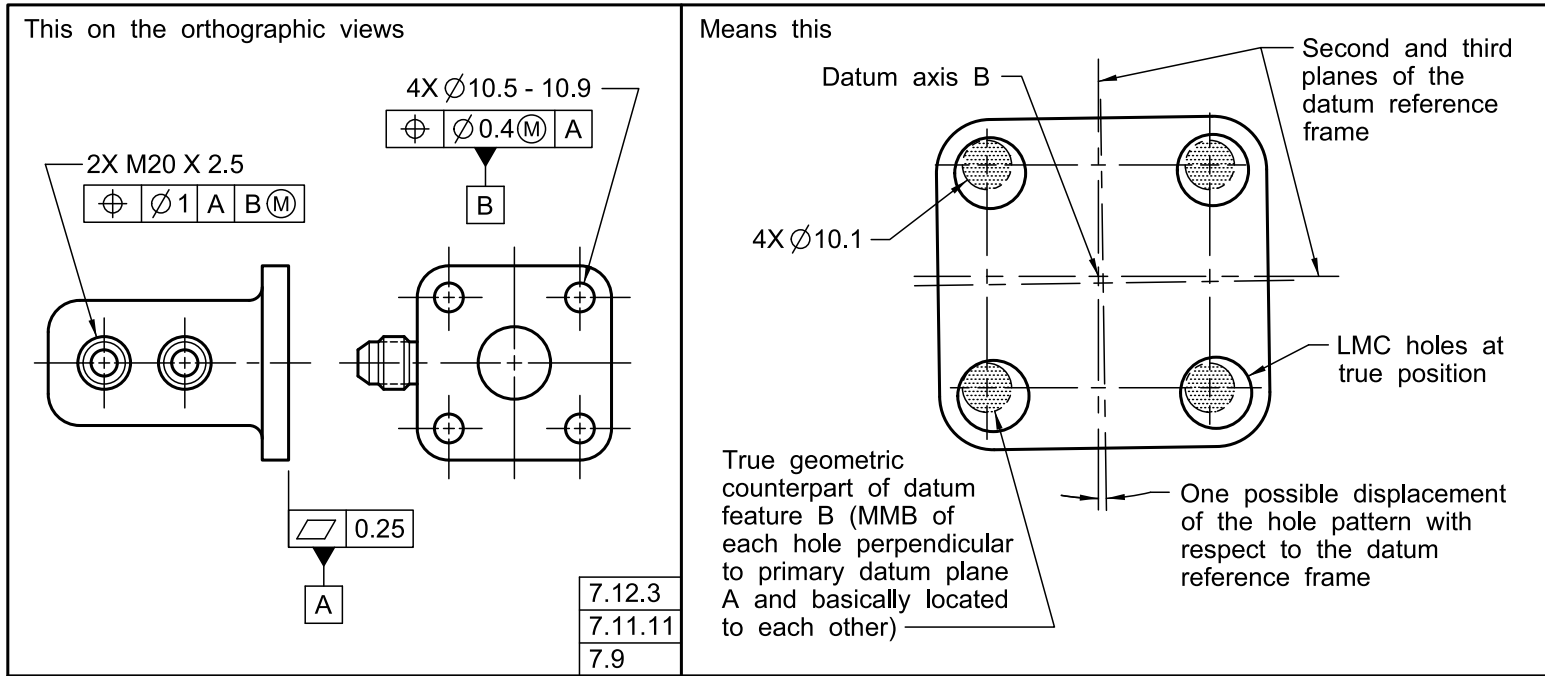

Figure 7-19 Effect of Secondary Datum Feature Reference Applicable RMB and at MMB

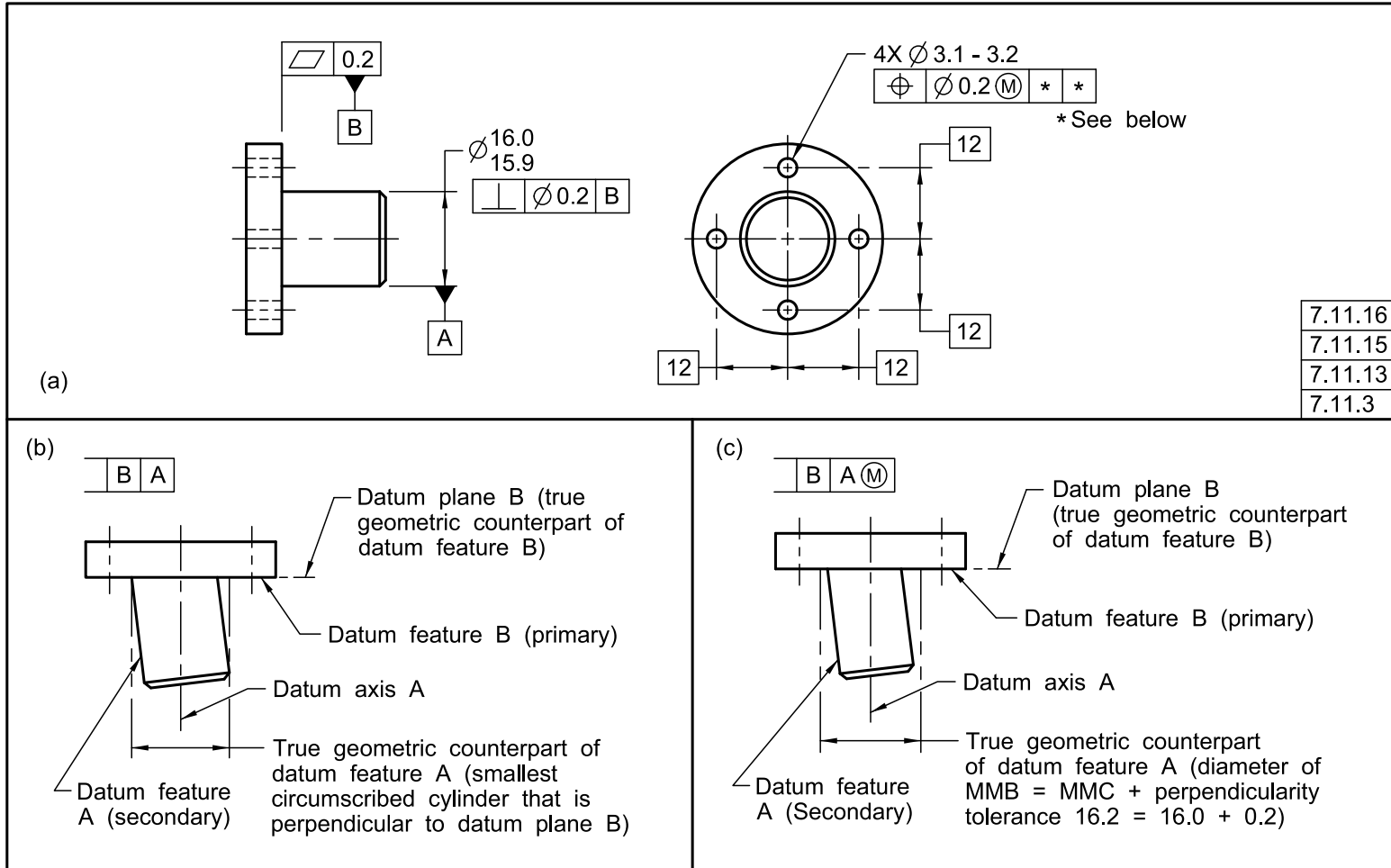

Figure 7-20 Effect of Primary Datum Feature Reference Applicable RMB and at MMB

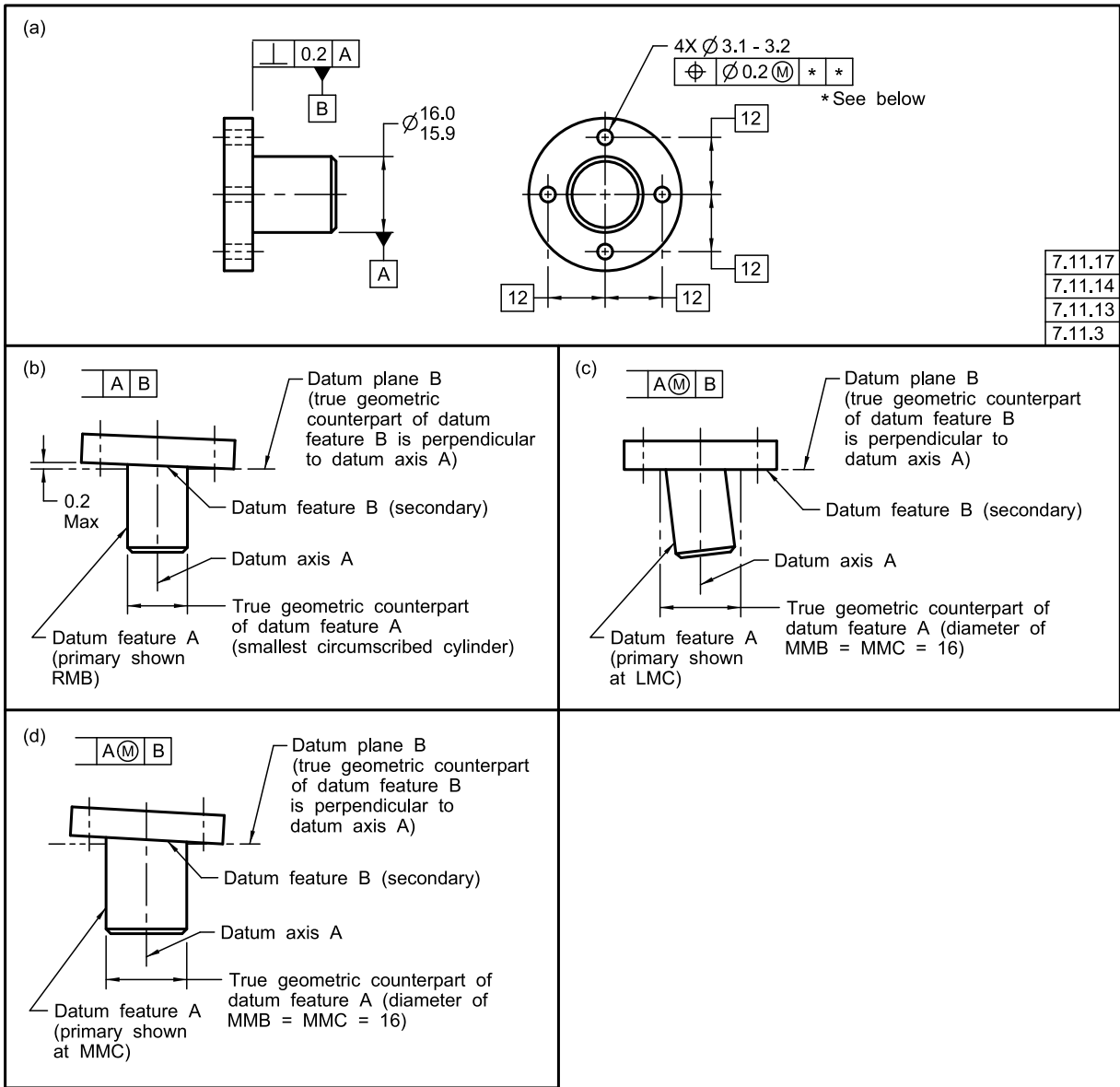

Figure 7-21 Secondary and Tertiary Datum Features RMB

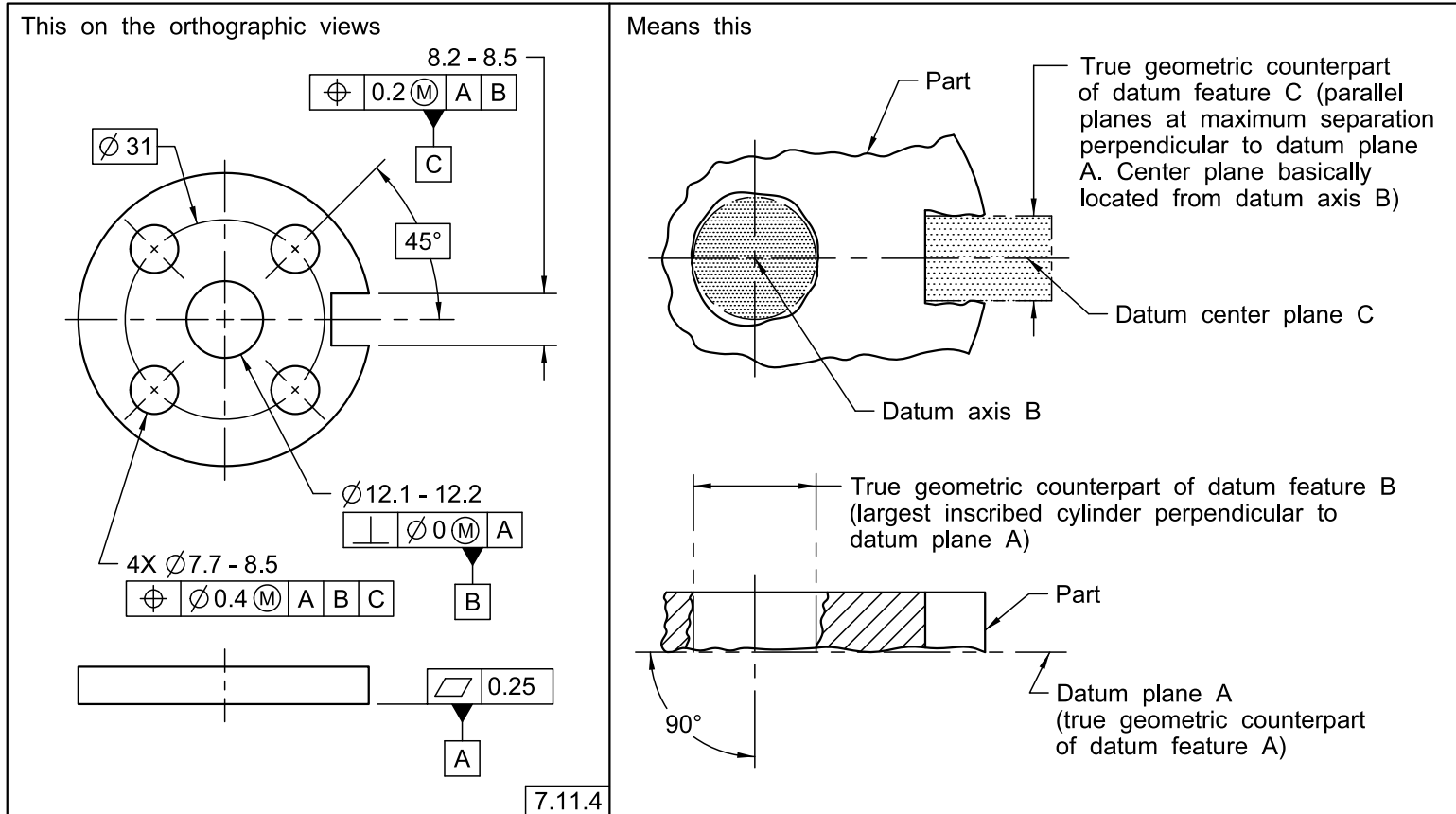
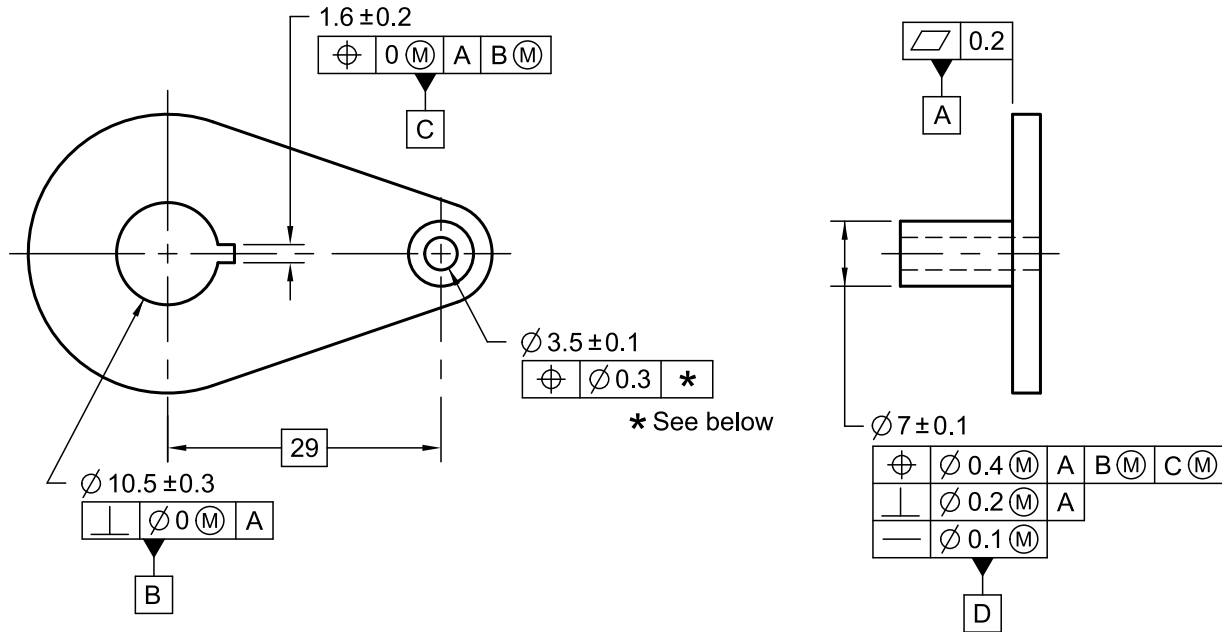

Figure 7-22 Example Calculations of MMB



Option	Geometric Control	Maximum Material Boundary of Datum Feature D
(a)	$\varnothing \varnothing 0.3 \text{ D (M)}$	$7.1 + 0.1 = 7.2$
(b)	$\varnothing \varnothing 0.3 \text{ A D (M)}$	$7.1 + 0.2 = 7.3$
(c)	$\varnothing \varnothing 0.3 \text{ A B (M) D (M)}$	$7.1 + 0.4 = 7.5$

8.4.1.3
7.11.6.2
7.11.6.1
7.11.6

Figure 7-23 Example Calculations of LMB

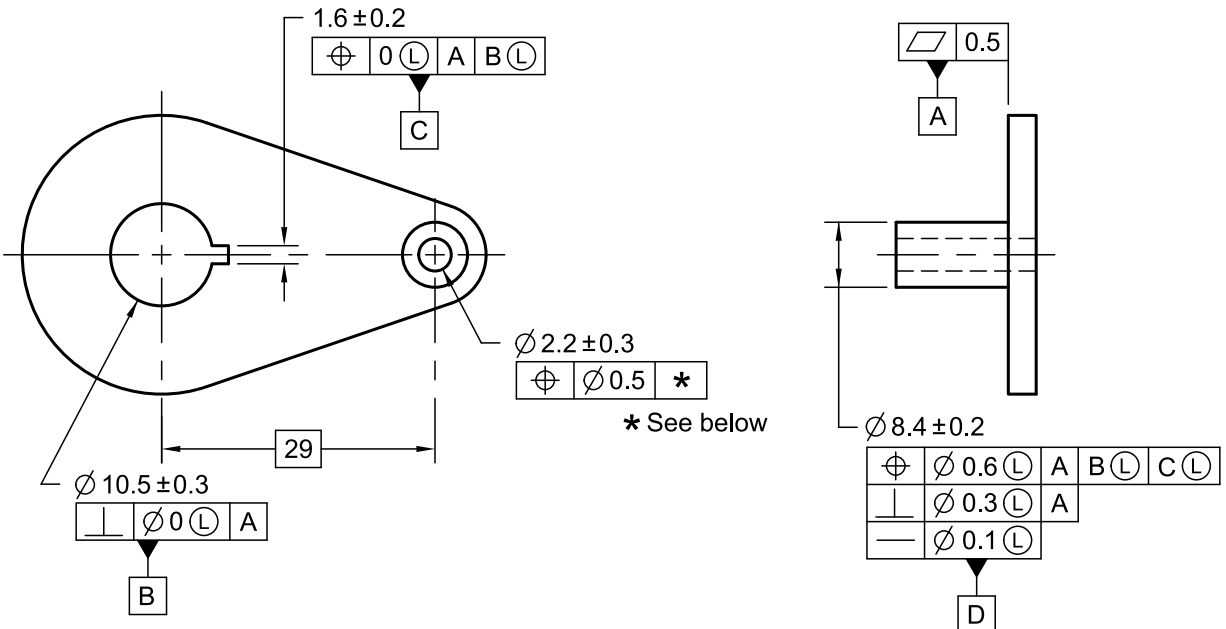

Option	Geometric Control	Least Material Boundary of Datum Feature D
(a)	$\oplus \ \phi 0.5 \ \text{D} \text{ (L)}$	$8.2 - 0.1 = 8.1$
(b)	$\oplus \ \phi 0.5 \ \text{A} \ \text{D} \text{ (L)}$	$8.2 - 0.3 = 7.9$
(c)	$\oplus \ \phi 0.5 \ \text{A} \ \text{B} \text{ (L)} \ \text{D} \text{ (L)}$	$8.2 - 0.6 = 7.6$

7.11.8.1
7.11.8

Figure 7-24 Example Calculations of Maximum External Boundary for RMB Applications

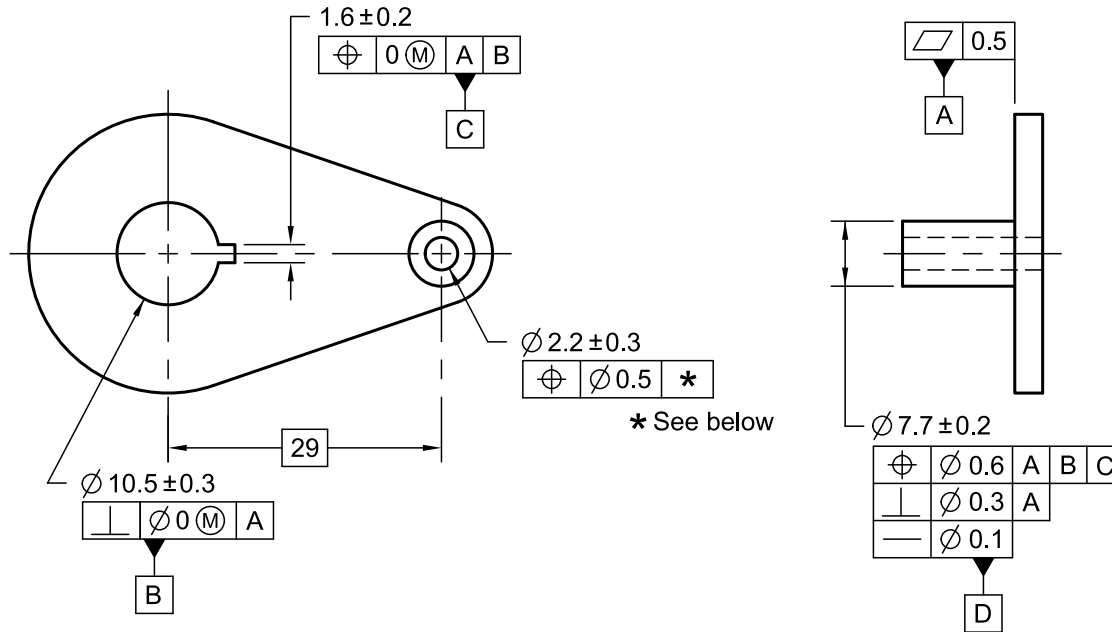

Option	Geometric Control	Maximum External Boundary of Datum Feature D
(a)	$\oplus \ \emptyset 0.5 \ D$	$7.9 + 0.1 = 8.0$
(b)	$\oplus \ \emptyset 0.5 \ A \ D$	$7.9 + 0.3 + 0.1 = 8.3$
(c)	$\oplus \ \emptyset 0.5 \ A \ B \ D$	$7.9 + 0.6 + 0.1 = 8.6$

7.11.9.1

Figure 7-25 Secondary and Tertiary Datum Features at LMB

This on the orthographic views

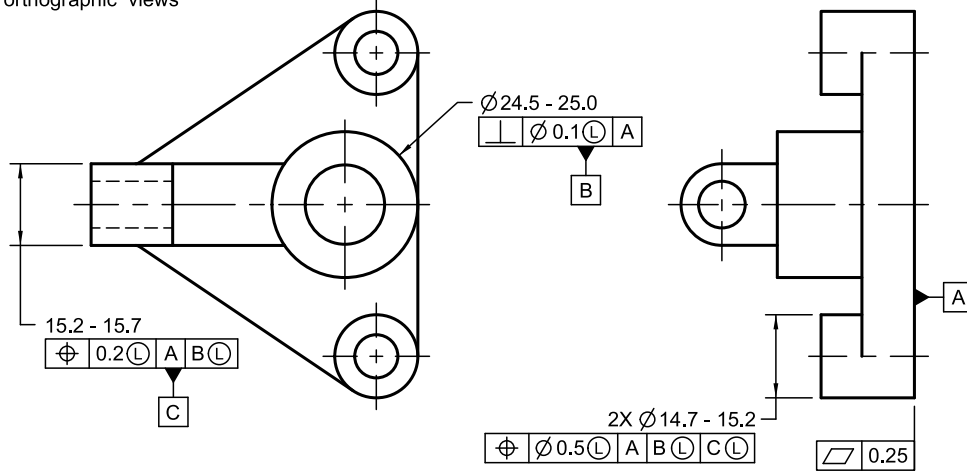

or this on the model

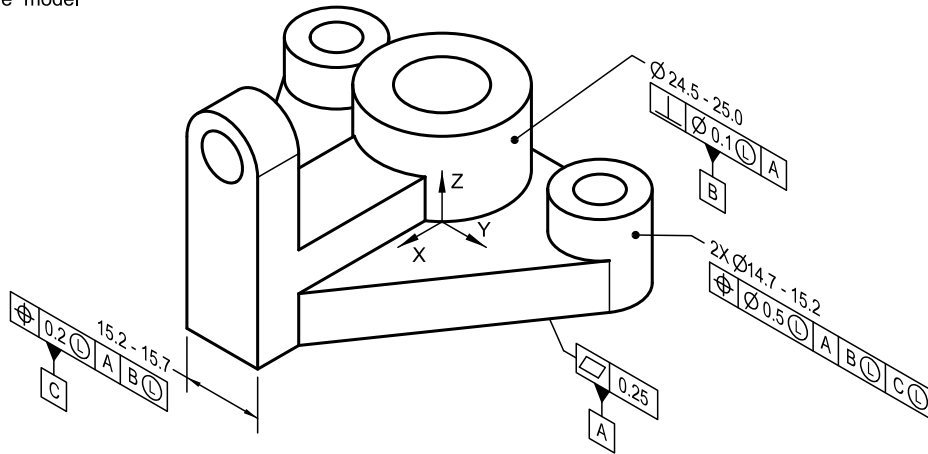

7.11.11

Means this

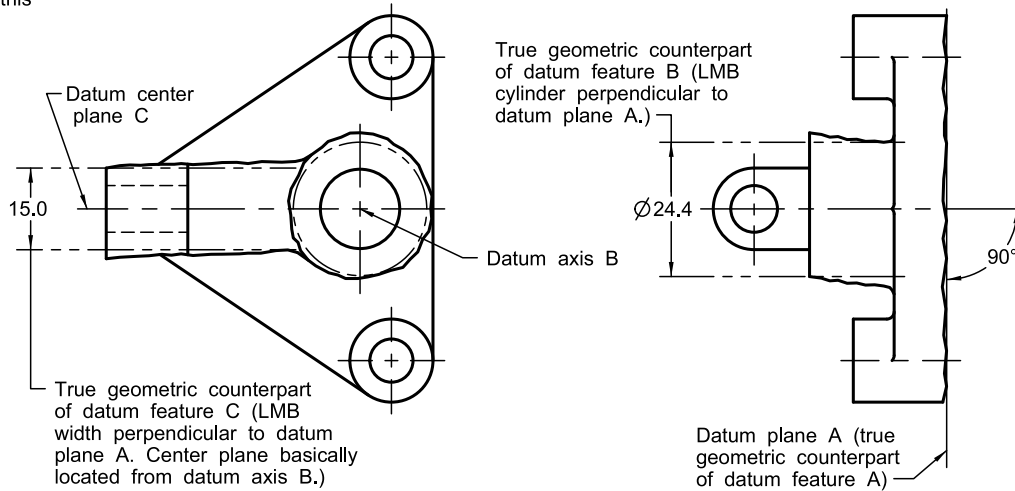

Figure 7-26 Secondary and Tertiary Datum Features at MMB

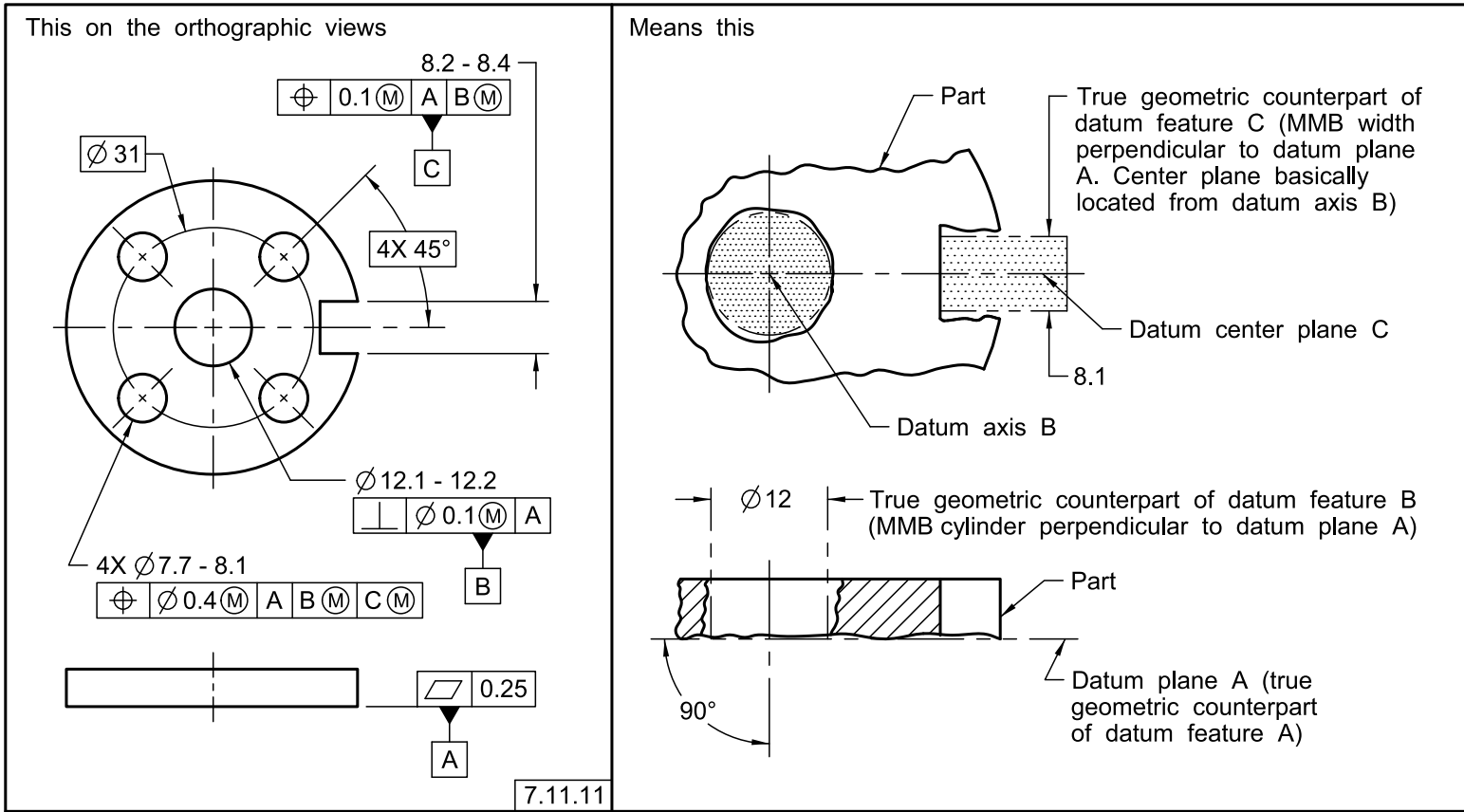

Figure 7-27 Planar Common Datum Features

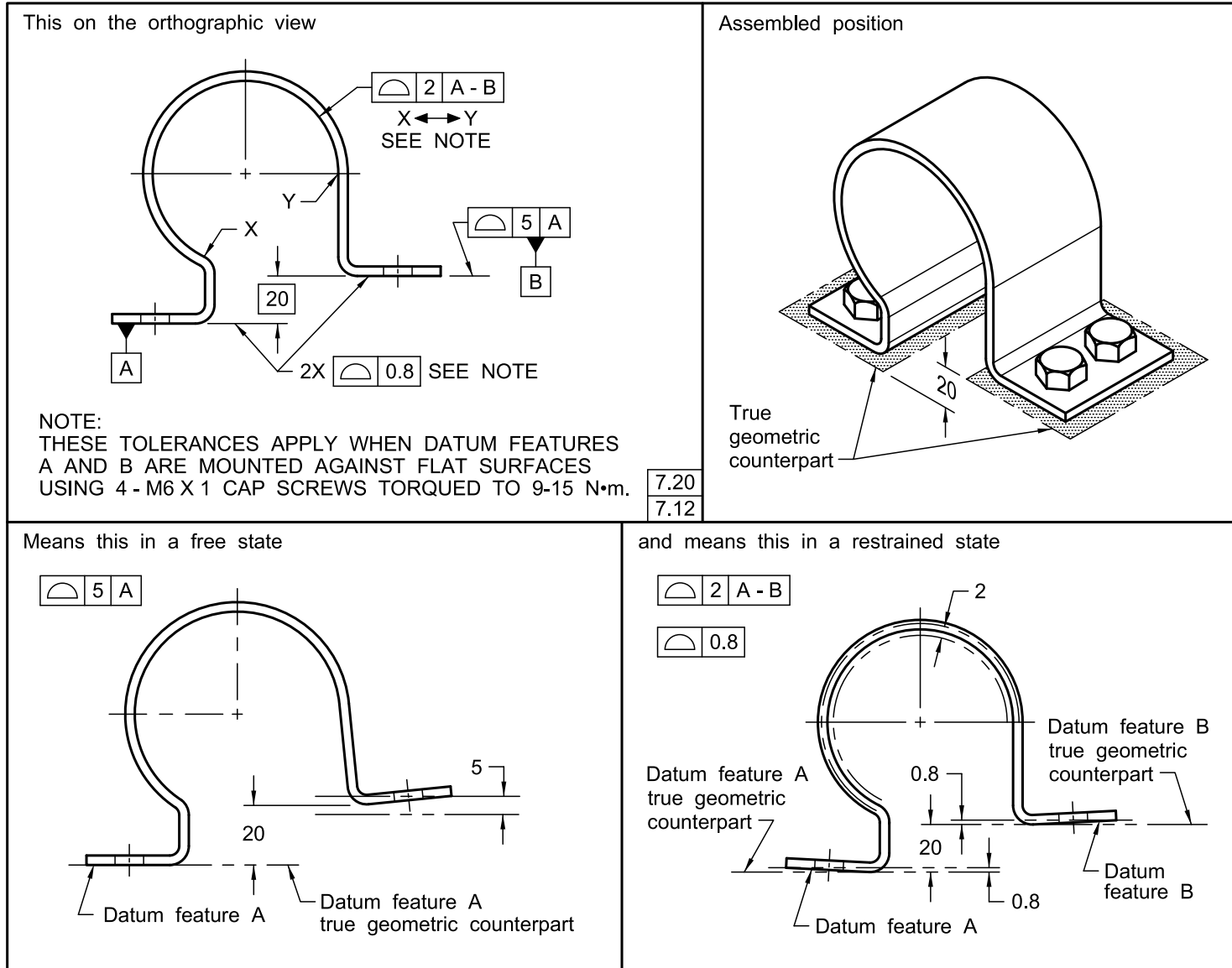

Figure 7-28 Partial Surface as a Datum Feature

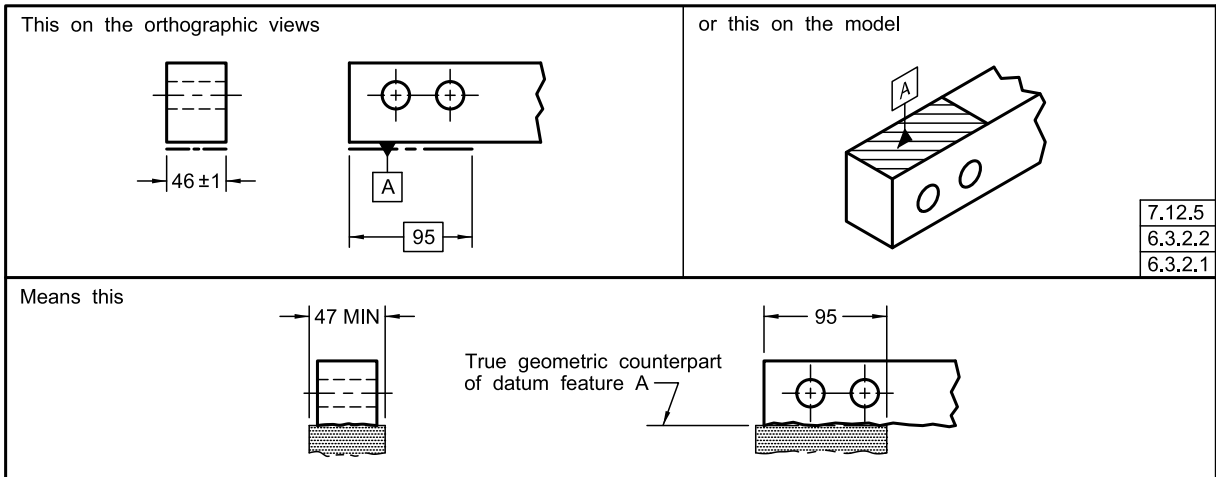
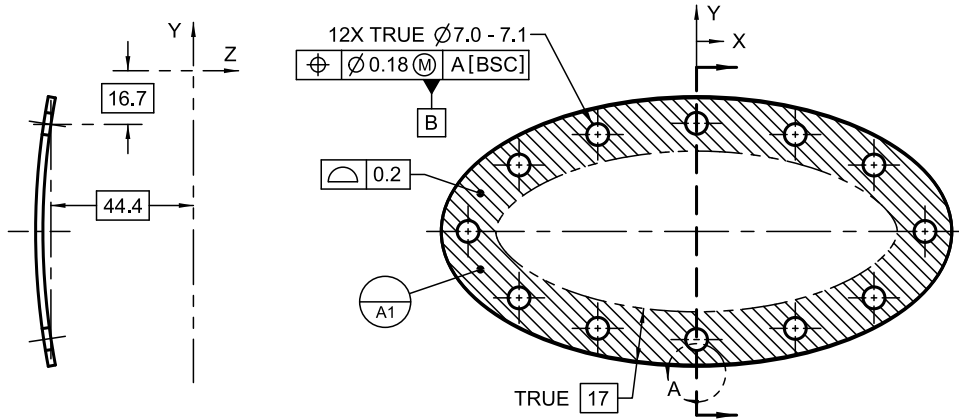
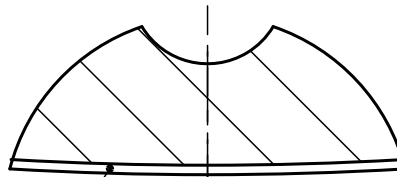

Figure 7-29 Contoured Surface as a Datum Feature

This on the orthographic views



NOTES:
 1 - THIS DRAWING SHALL BE USED WITH MODEL 123-4567 FOR COMPLETE PRODUCT DEFINITION
 2 - THIS DRAWING MADE IN ACCORDANCE WITH ASME Y14.41-2012



DETAIL A
SCALE 7:1

7.13
7.12.3
7.11.4
4.5.2.3

Means this

12X Ø 6.82 MMB
 True geometric counterpart of datum feature B

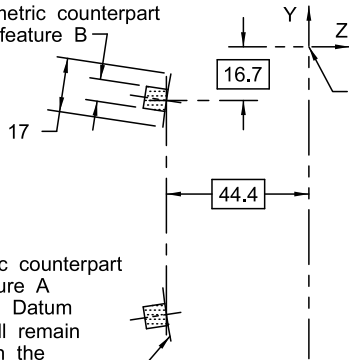

True geometric counterpart of datum feature A fixed at basic. Datum feature A shall remain in contact with the true geometric counterpart

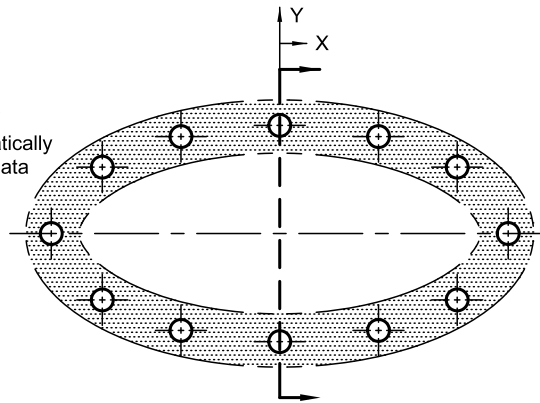

Figure 7-30 Contoured Datum Feature Constraining a Rotational Degree of Freedom: Secondary Datum Feature RMB

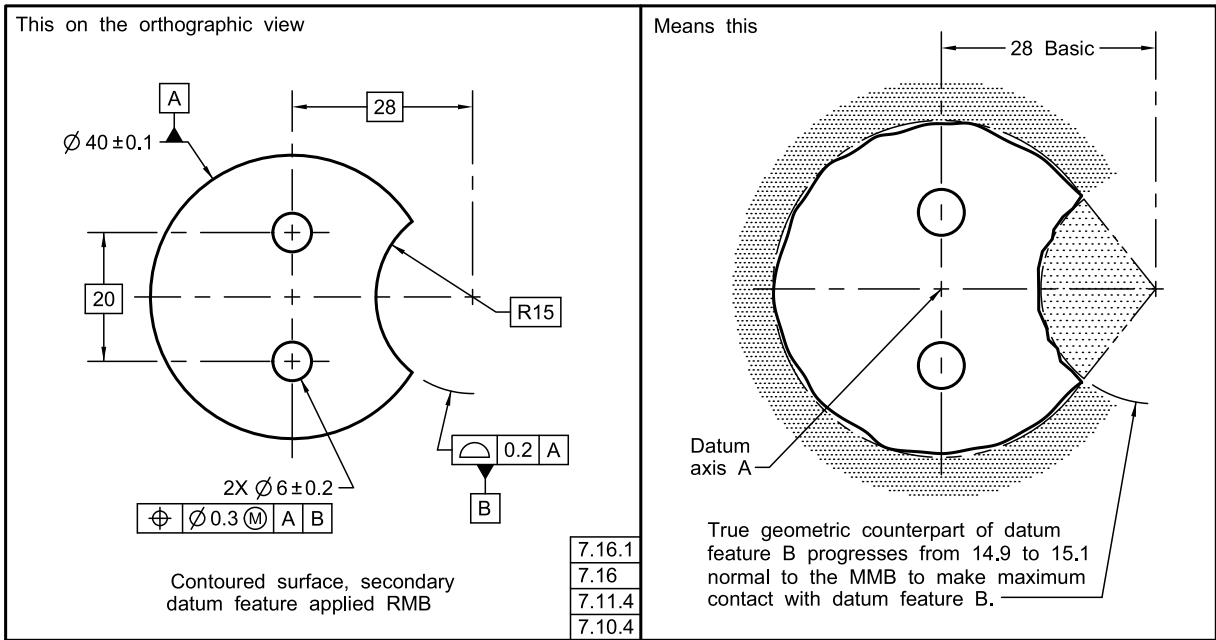

Figure 7-31 Contoured Datum Feature Constraining a Rotational Degree of Freedom: Secondary Datum Feature at MMB

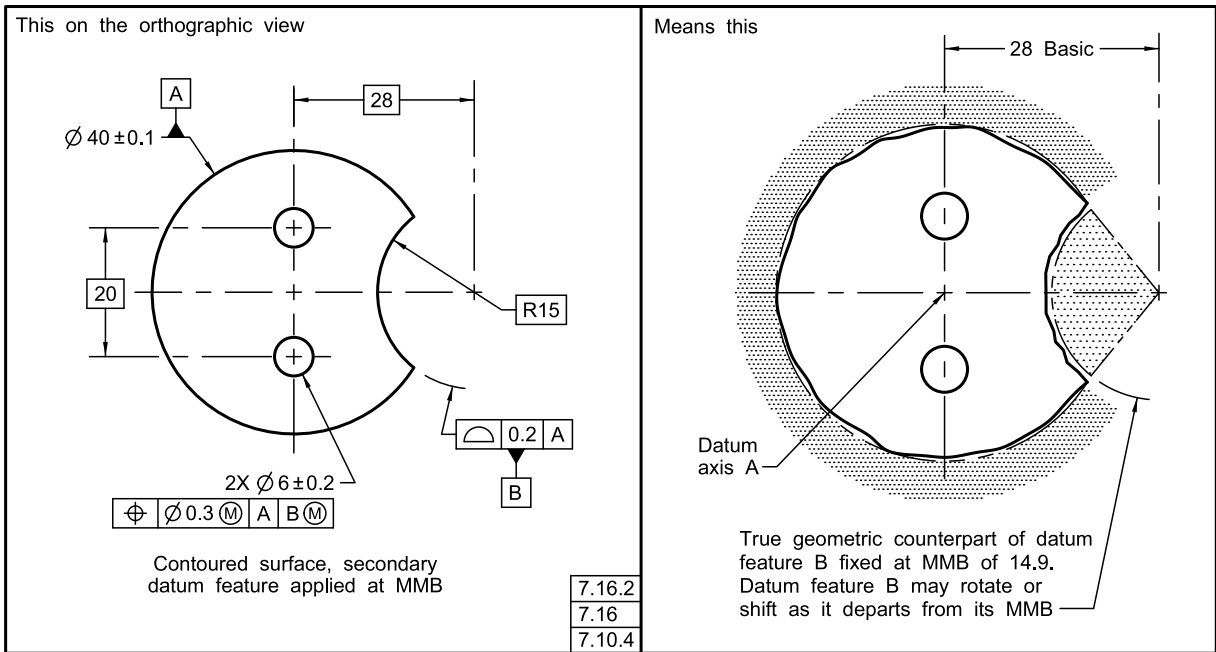

Figure 7-32 Planar Datum Feature Constraining a Rotational Degree of Freedom: Secondary Datum Feature RMB

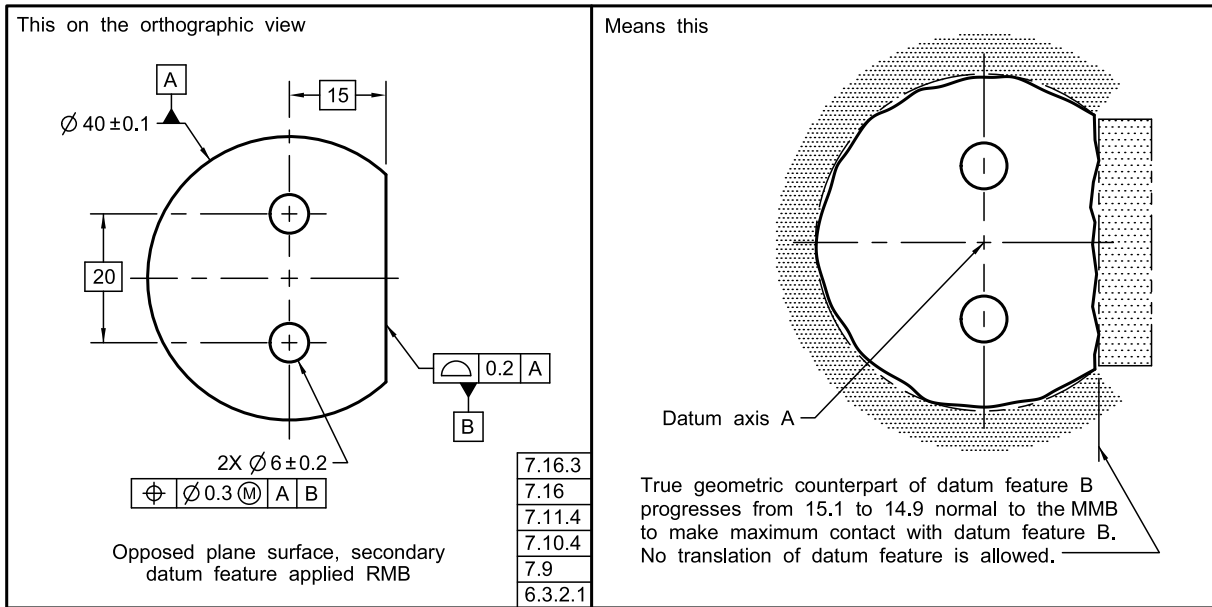

Figure 7-33 Planar Datum Feature Constraining a Rotational Degree of Freedom: Secondary Datum Feature at MMB

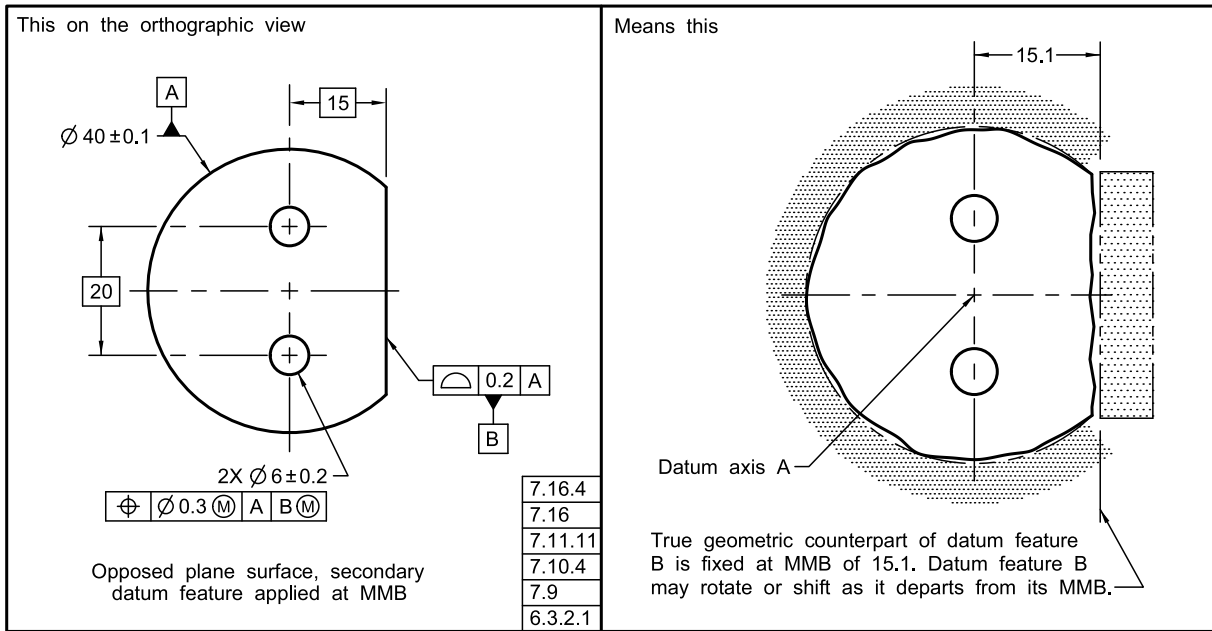

Figure 7-34 Planar Datum Feature Constraining a Rotational Degree of Freedom: Secondary Datum Feature RMB

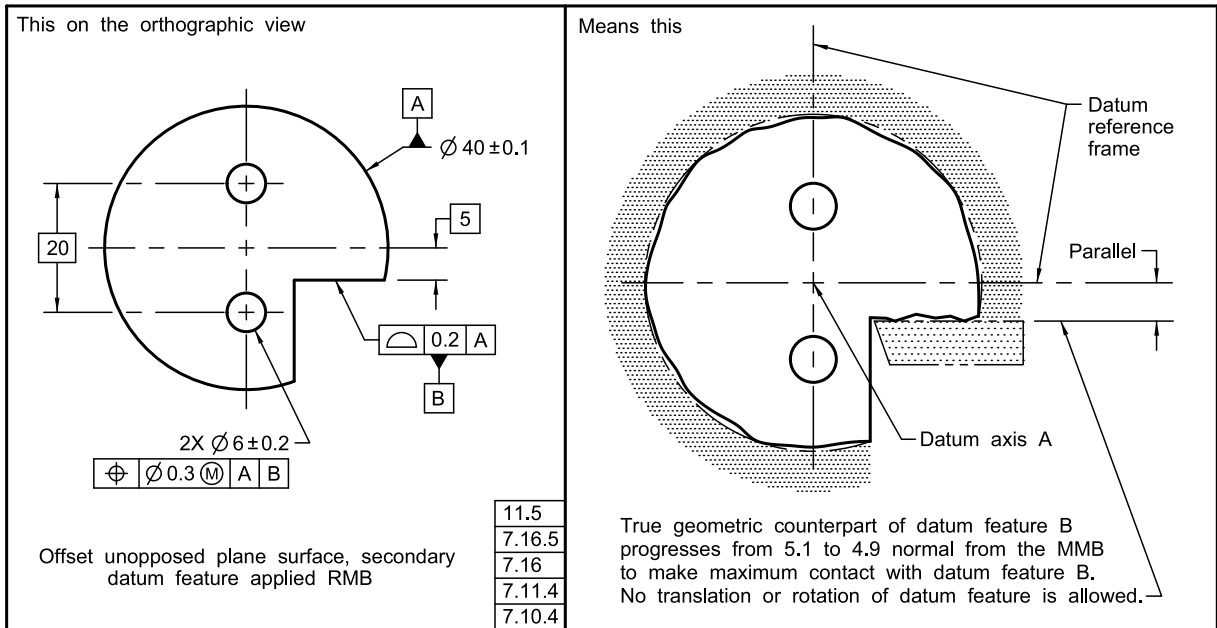

Figure 7-35 Planar Datum Feature Constraining a Rotational Degree of Freedom: Secondary Datum Feature at BSC

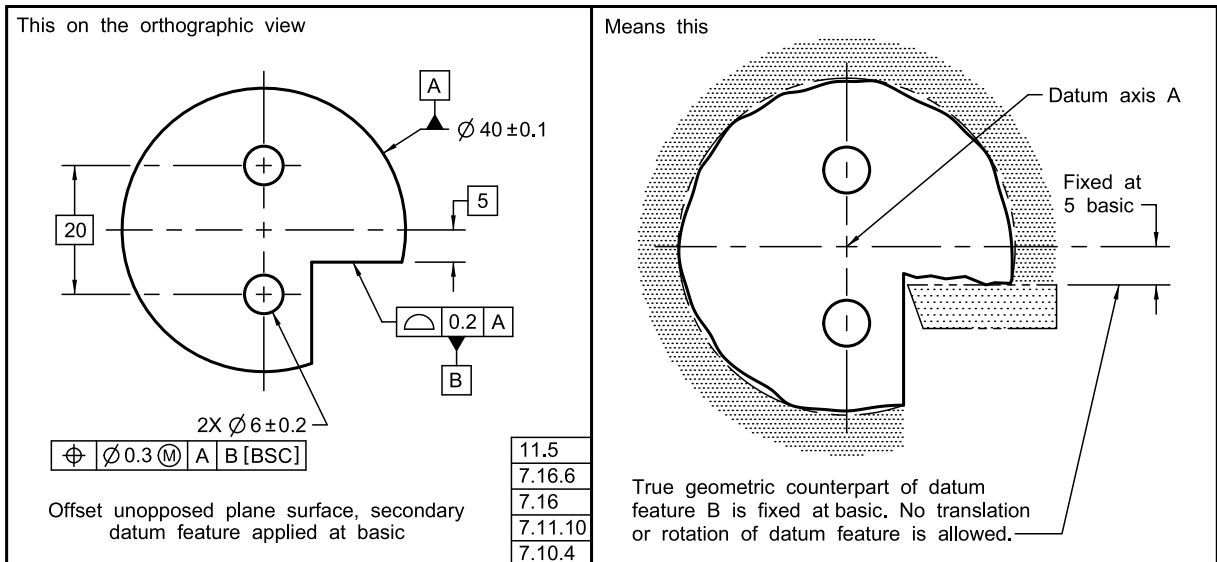

Figure 7-36 Planar Datum Feature Constraining a Rotational Degree of Freedom: Secondary Datum Feature at MMB

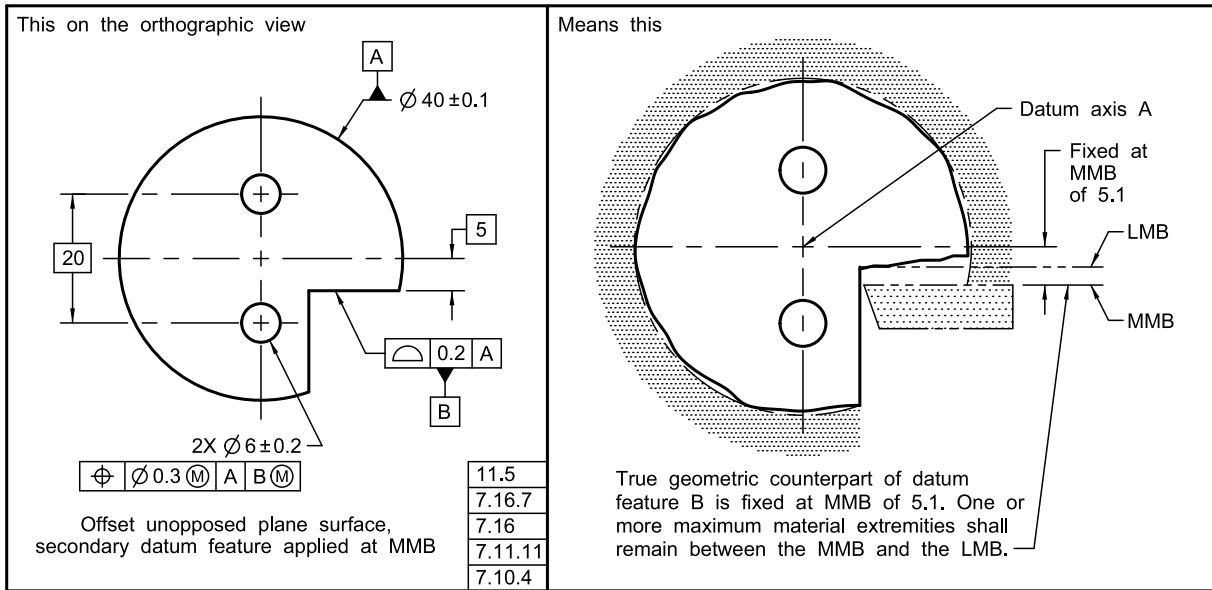

Figure 7-37 Planar Datum Feature Constraining a Rotational Degree of Freedom: Secondary Datum Feature at LMB

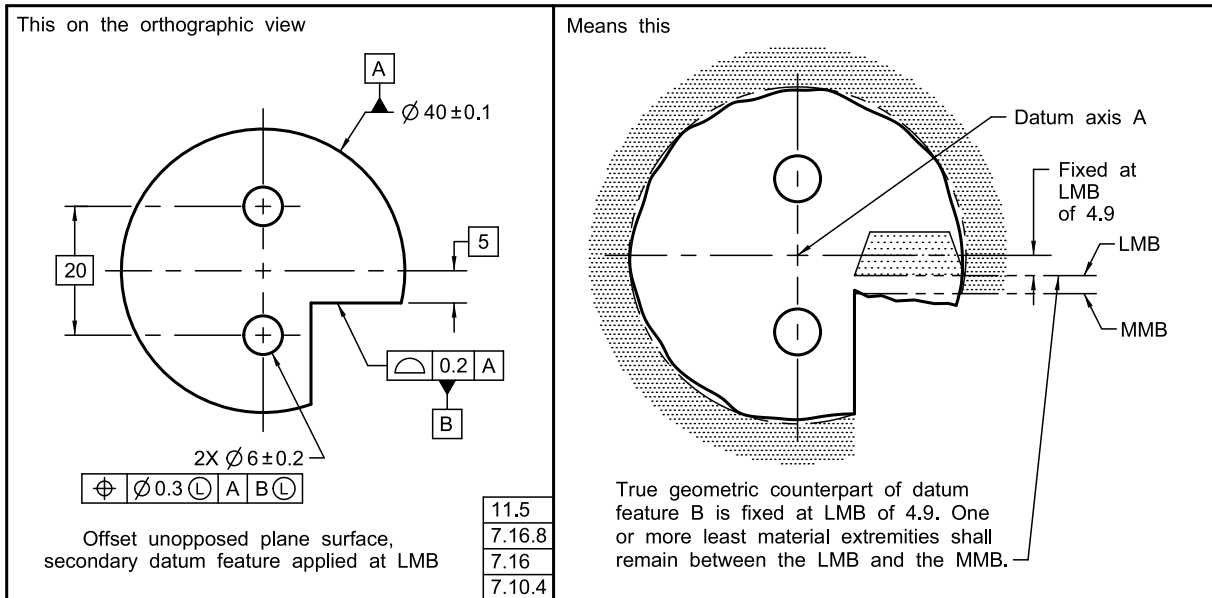

Figure 7-38 Size Datum Feature Constraining a Rotational Degree of Freedom: Secondary Datum Feature RMB

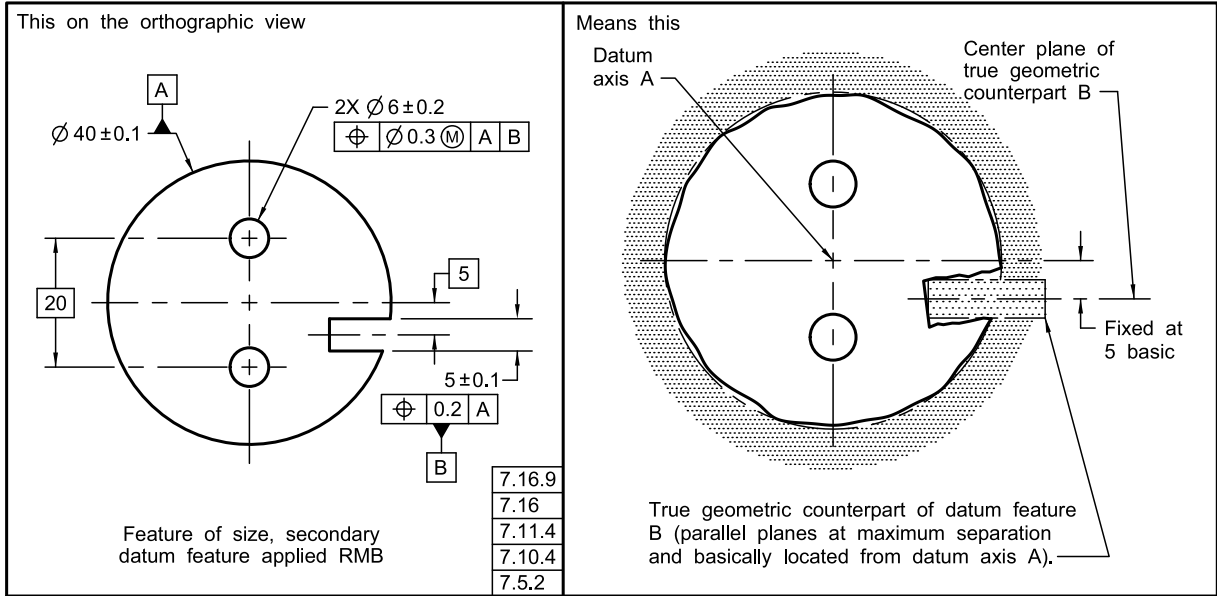

Figure 7-39 Size Datum Feature Constraining a Rotational Degree of Freedom: Secondary Datum Feature RMB, Translate

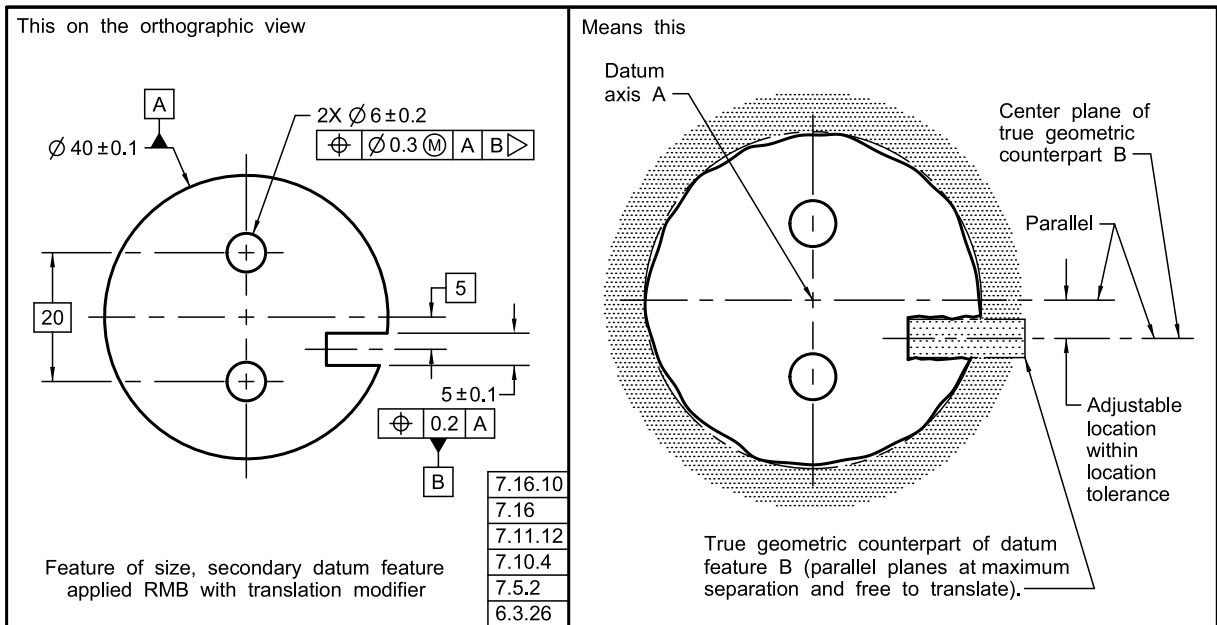

Figure 7-40 Irregular and Regular Features of Size as Datum Features

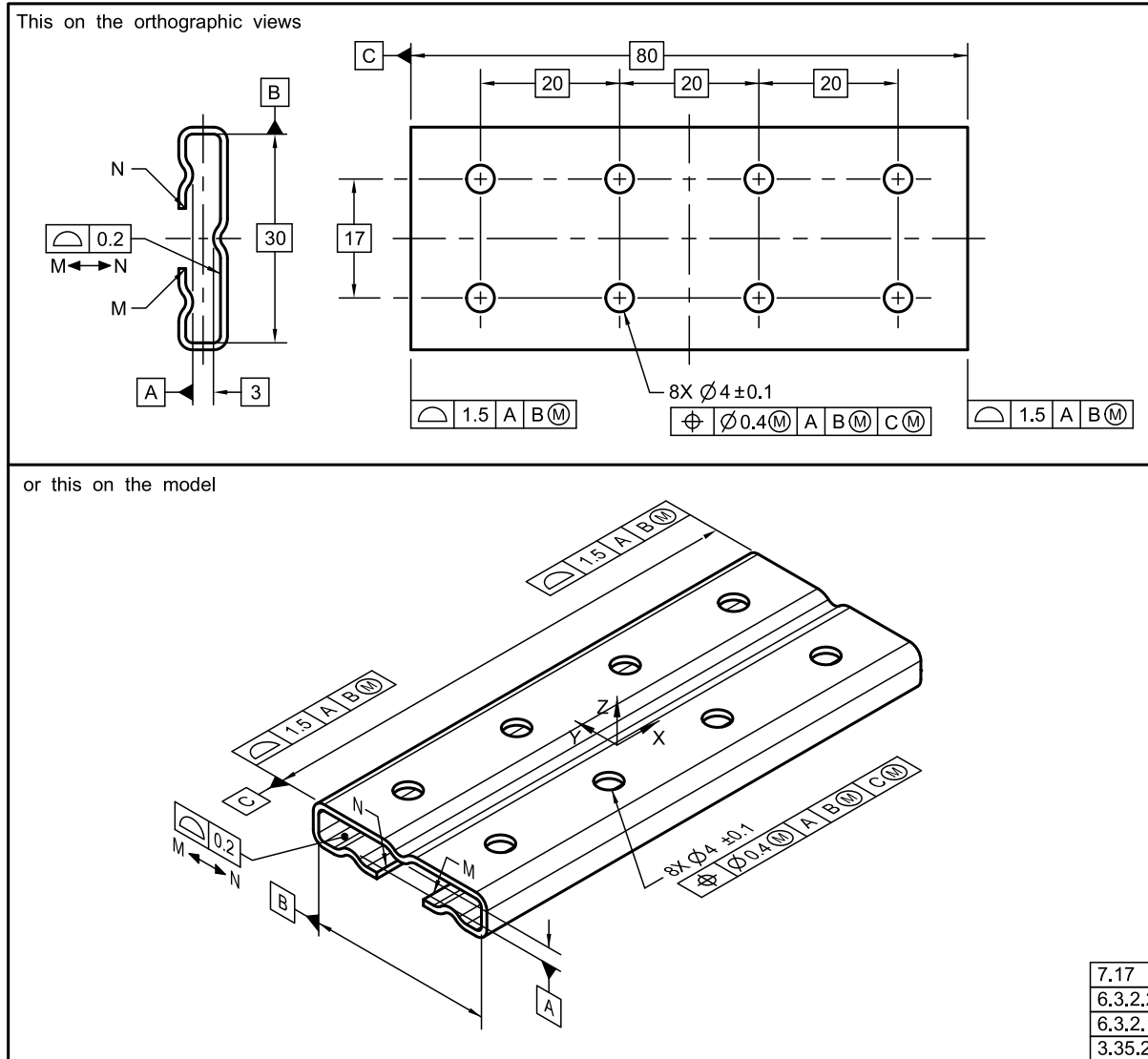

Figure 7-40 Irregular and Regular Features of Size as Datum Features (Cont'd)

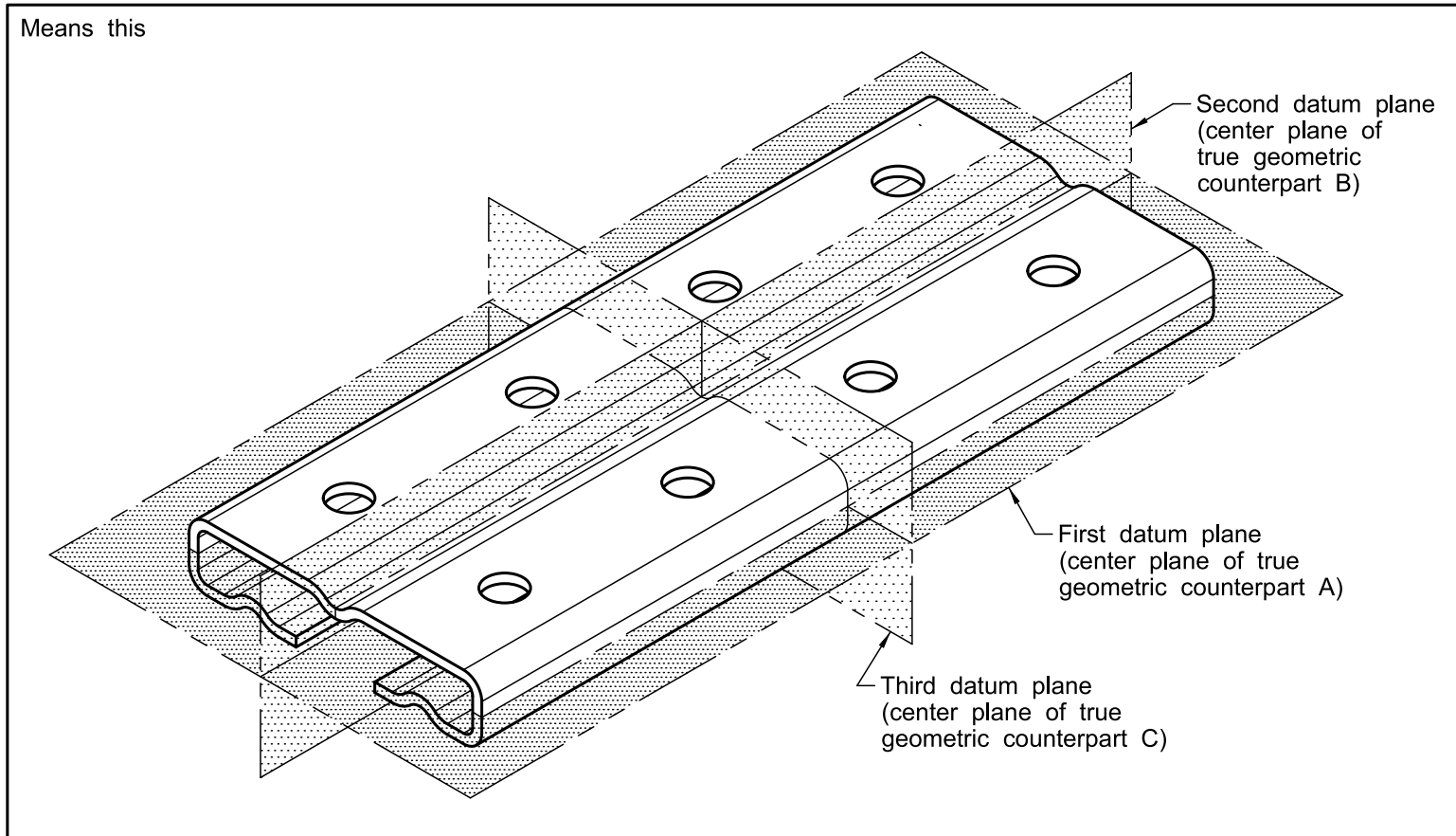
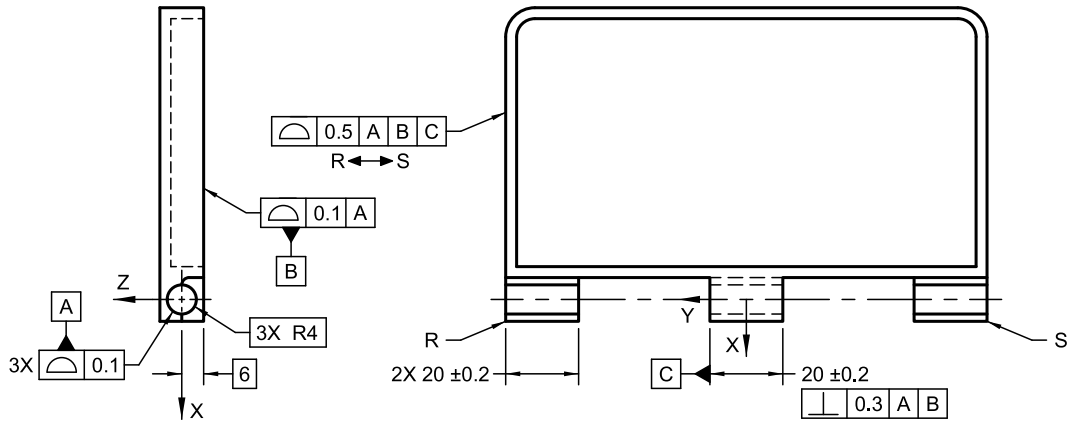
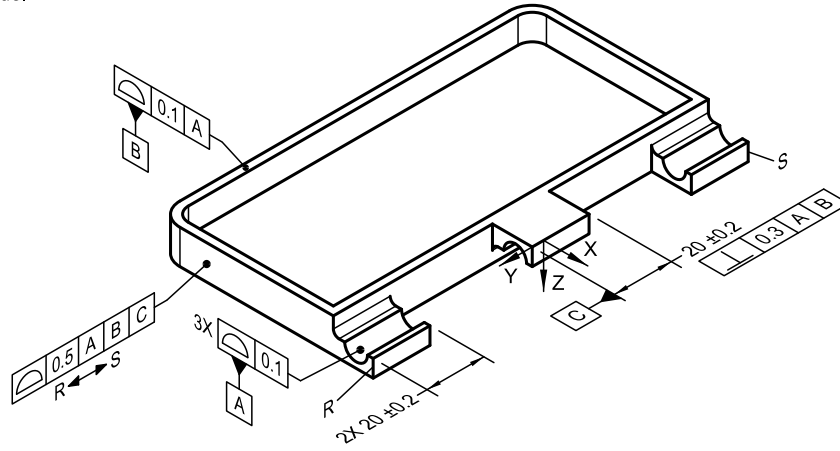

Figure 7-41 Coaxial Irregular Datum Feature of Size

This on the orthographic views



or this on the model



7.17
3.35.2

Figure 7-41 Coaxial Irregular Datum Feature of Size (Cont'd)

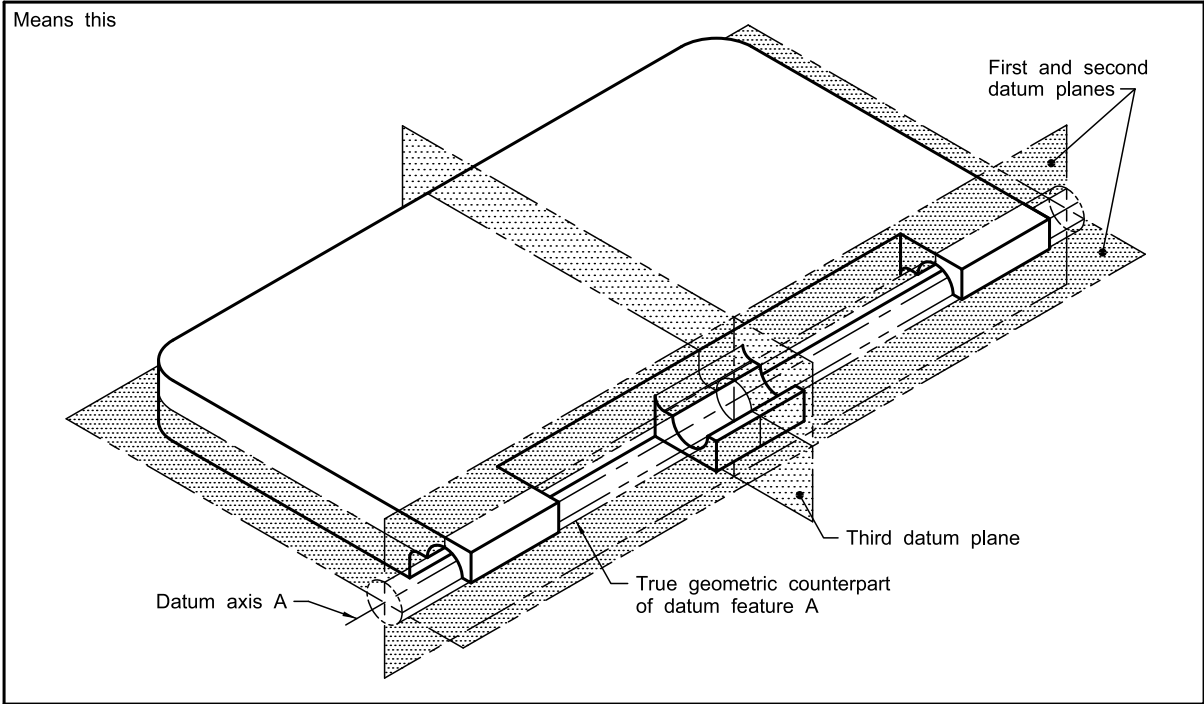

Figure 7-42 Possible Datum Feature and True Geometric Counterparts From Three Pins Used as an Irregular Feature of Size

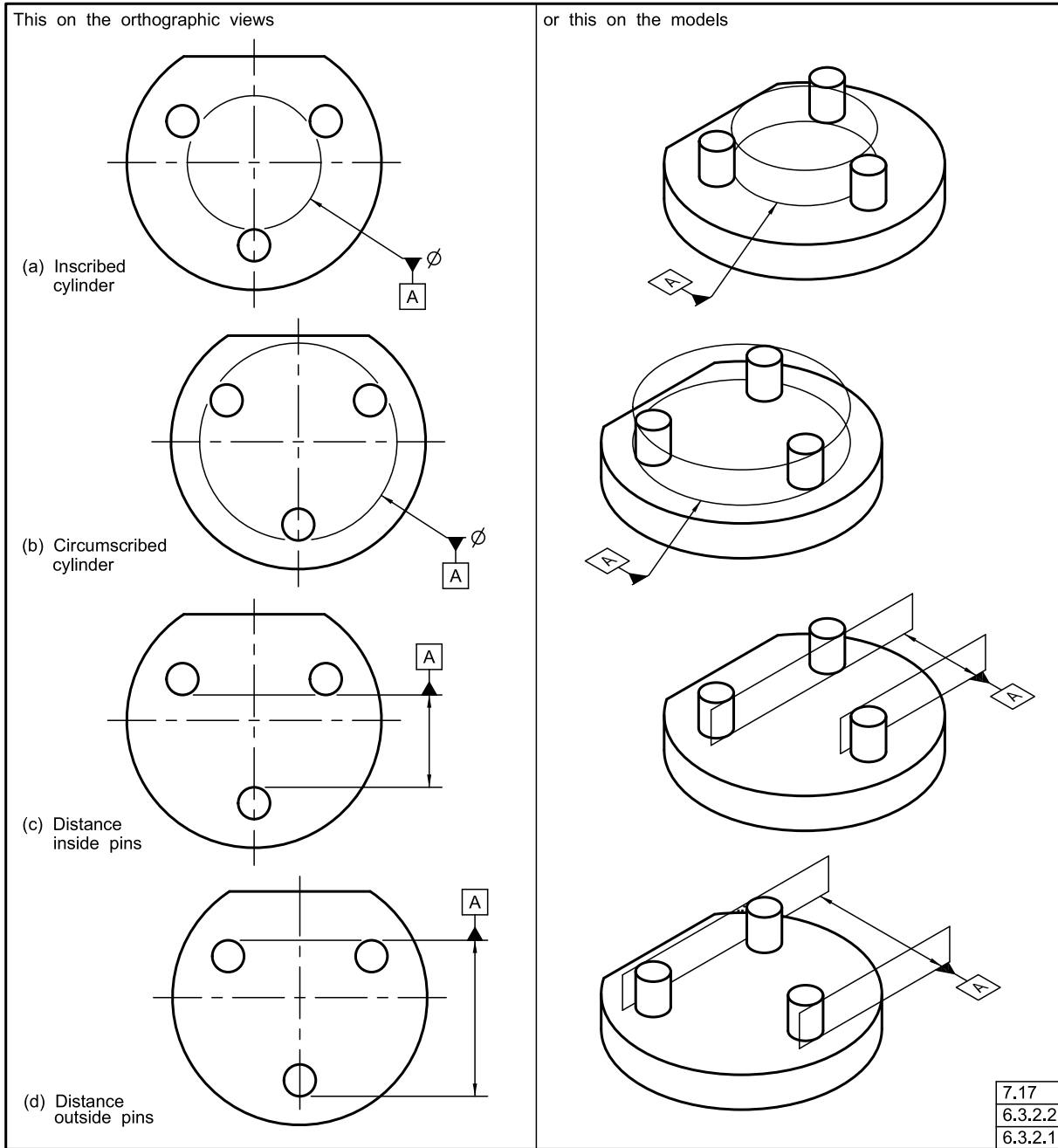

Figure 7-42 Possible Datum Feature and True Geometric Counterparts From Three Pins Used as an Irregular Feature of Size (Cont'd)

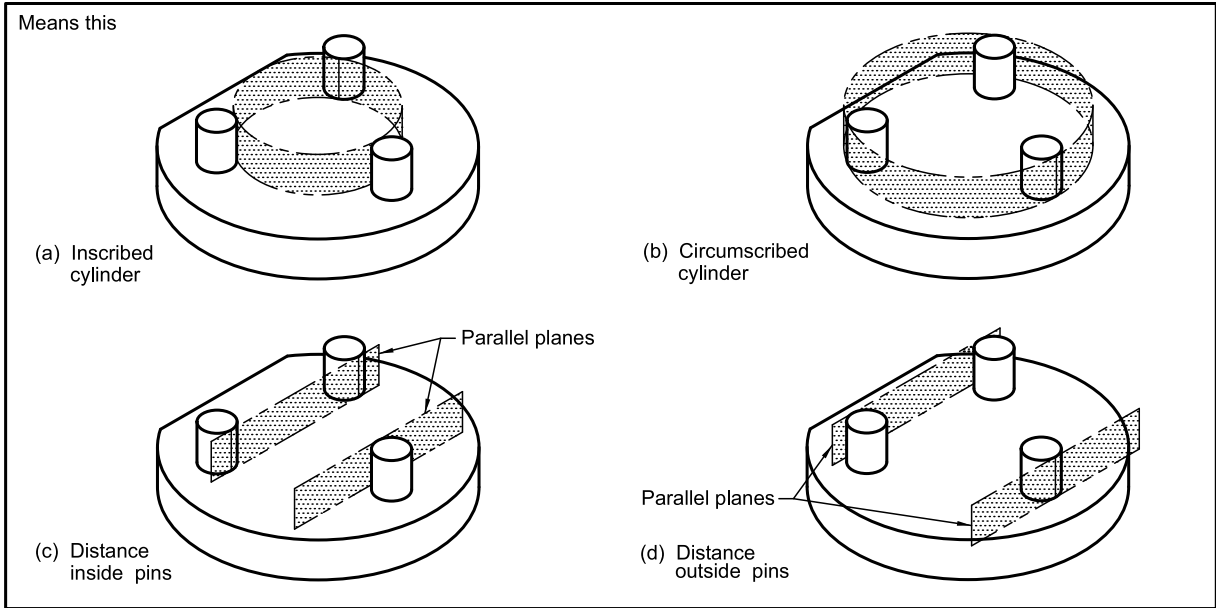

Figure 7-43 Mating Parts for Functional Datum Section

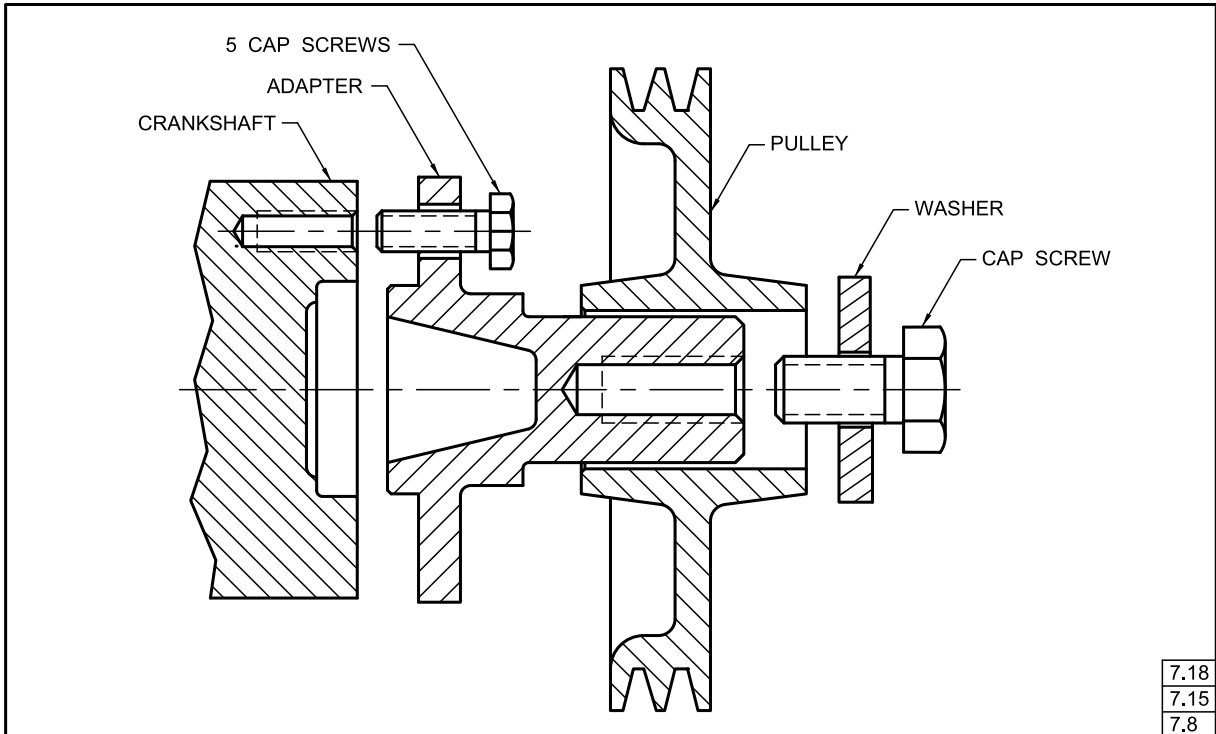

Figure 7-44 Functional Datum Application: Pulley

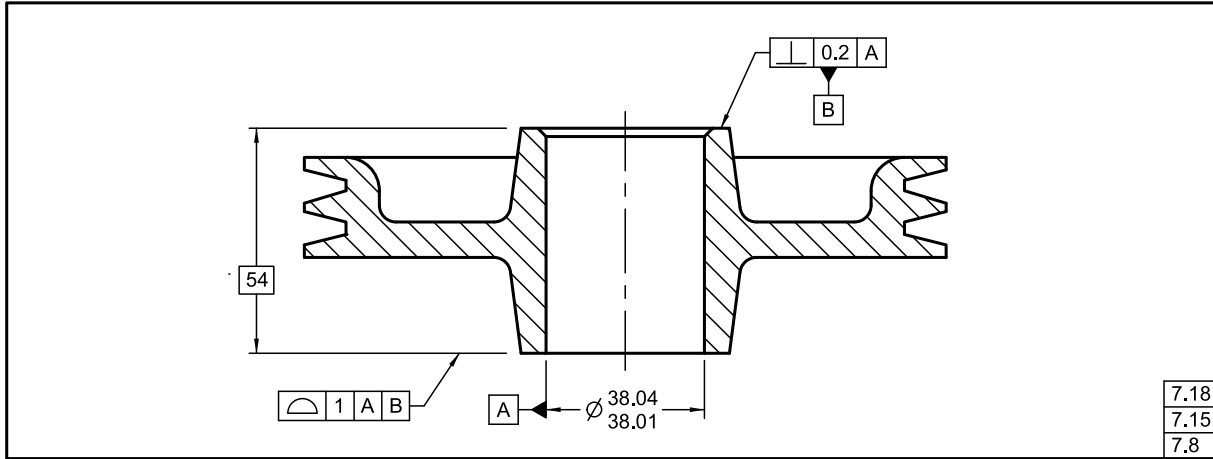

Figure 7-45 Functional Datum Application: Adapter

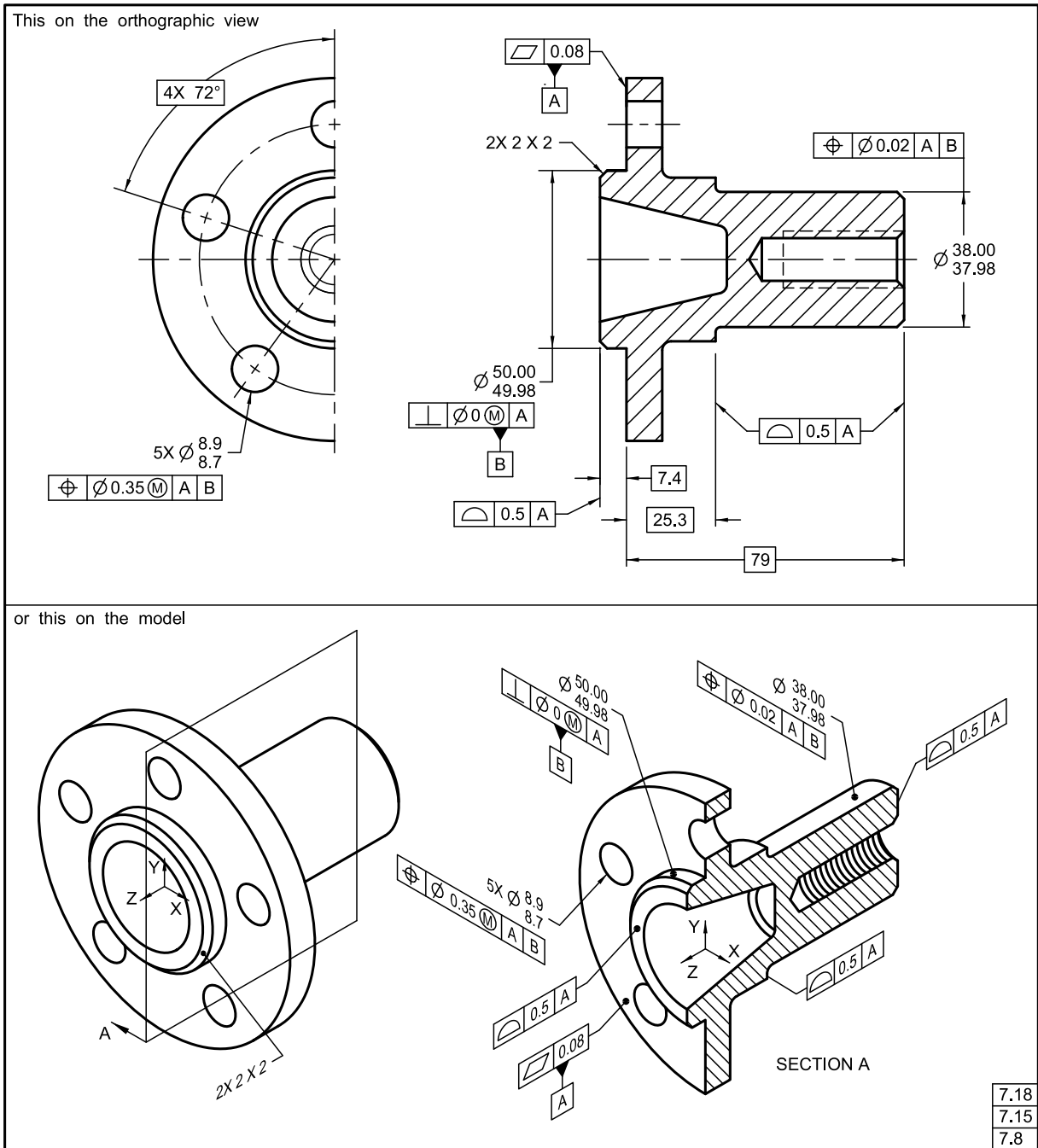
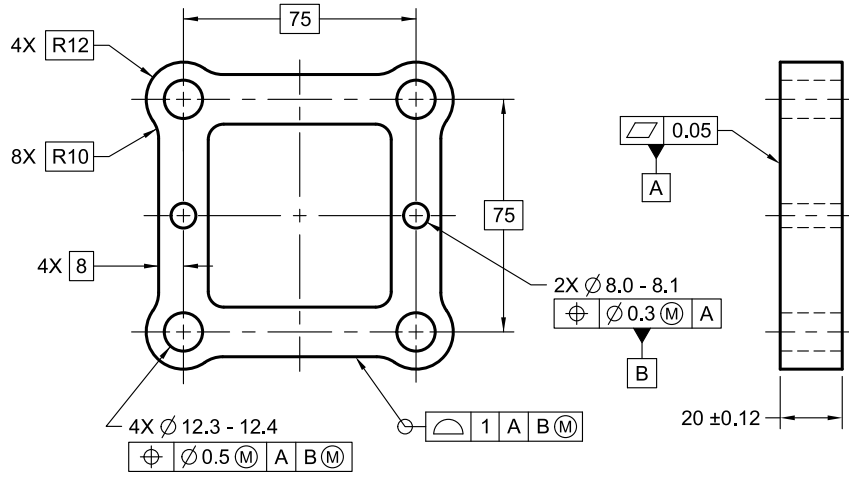

Figure 7-46 Simultaneous Position and Profile Tolerances

This on the orthographic views



11.5
7.19
4.6.5

Means this

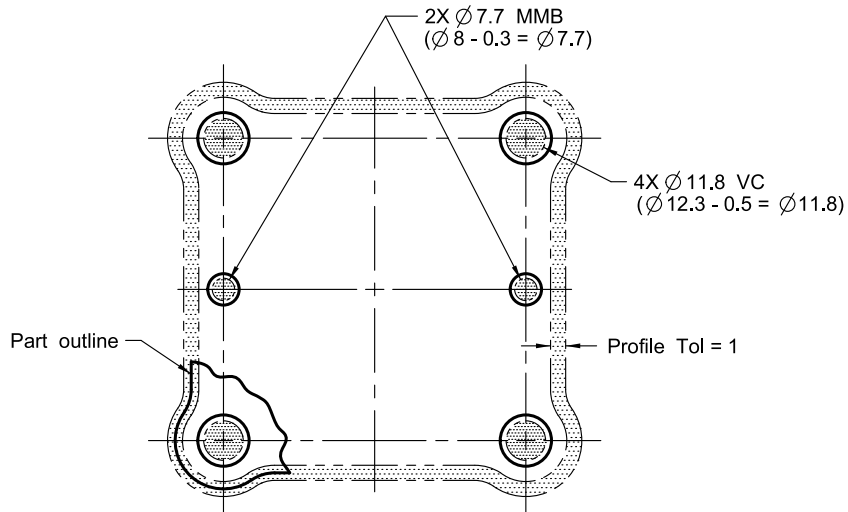

Figure 7-47 Part With Nominally Aligned Features: Simultaneous Requirement

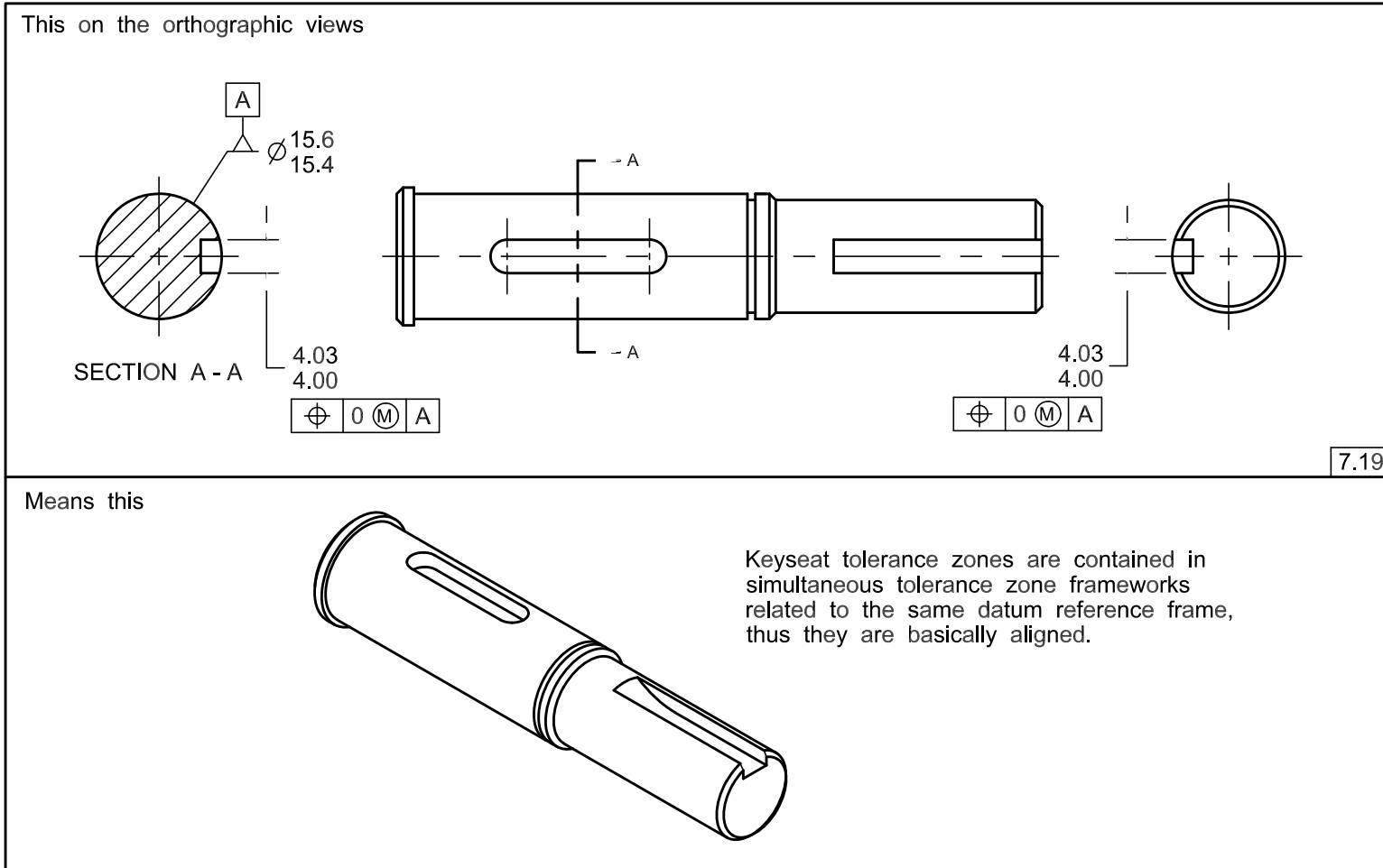

Figure 7-48 Part With Nominally Aligned Features: Separate Requirements

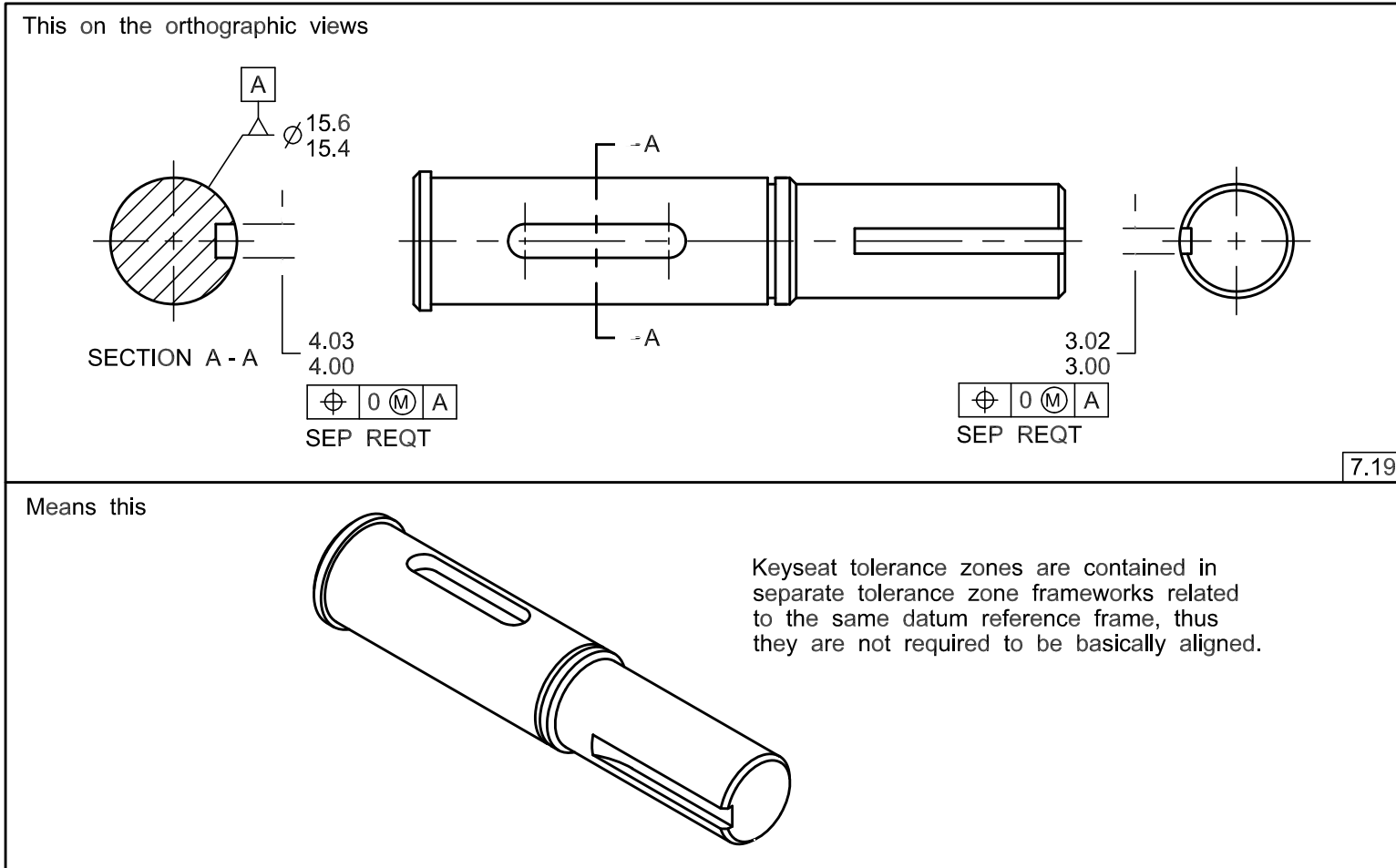

Figure 7-49 Restrained Condition Application

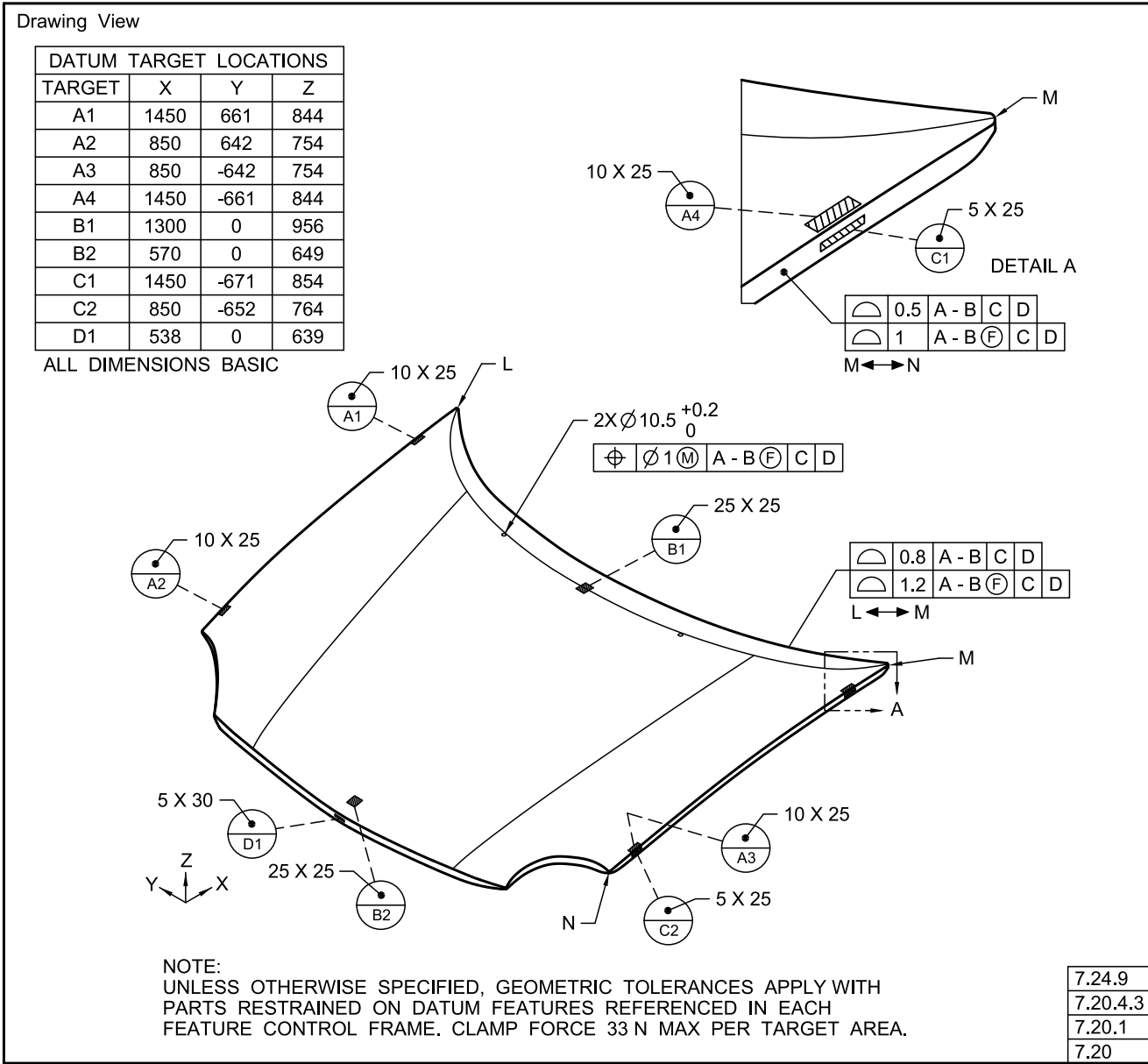

Figure 7-50 Indication of Unrestrained Datum Targets for a Primary Multiple Datum Feature Reference

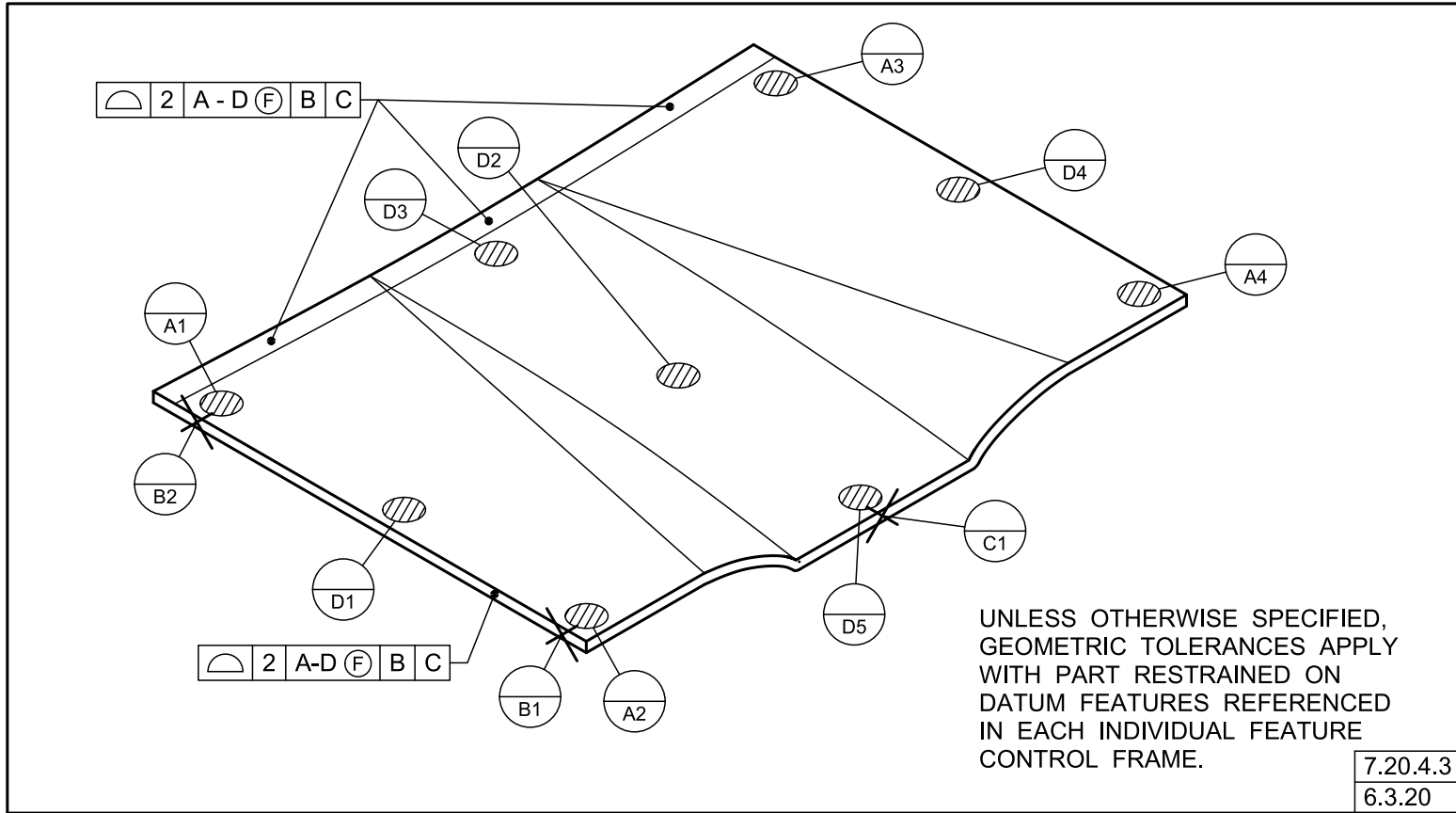

Figure 7-51 Indication of Unrestrained Datum Targets for a Secondary Datum Feature Reference

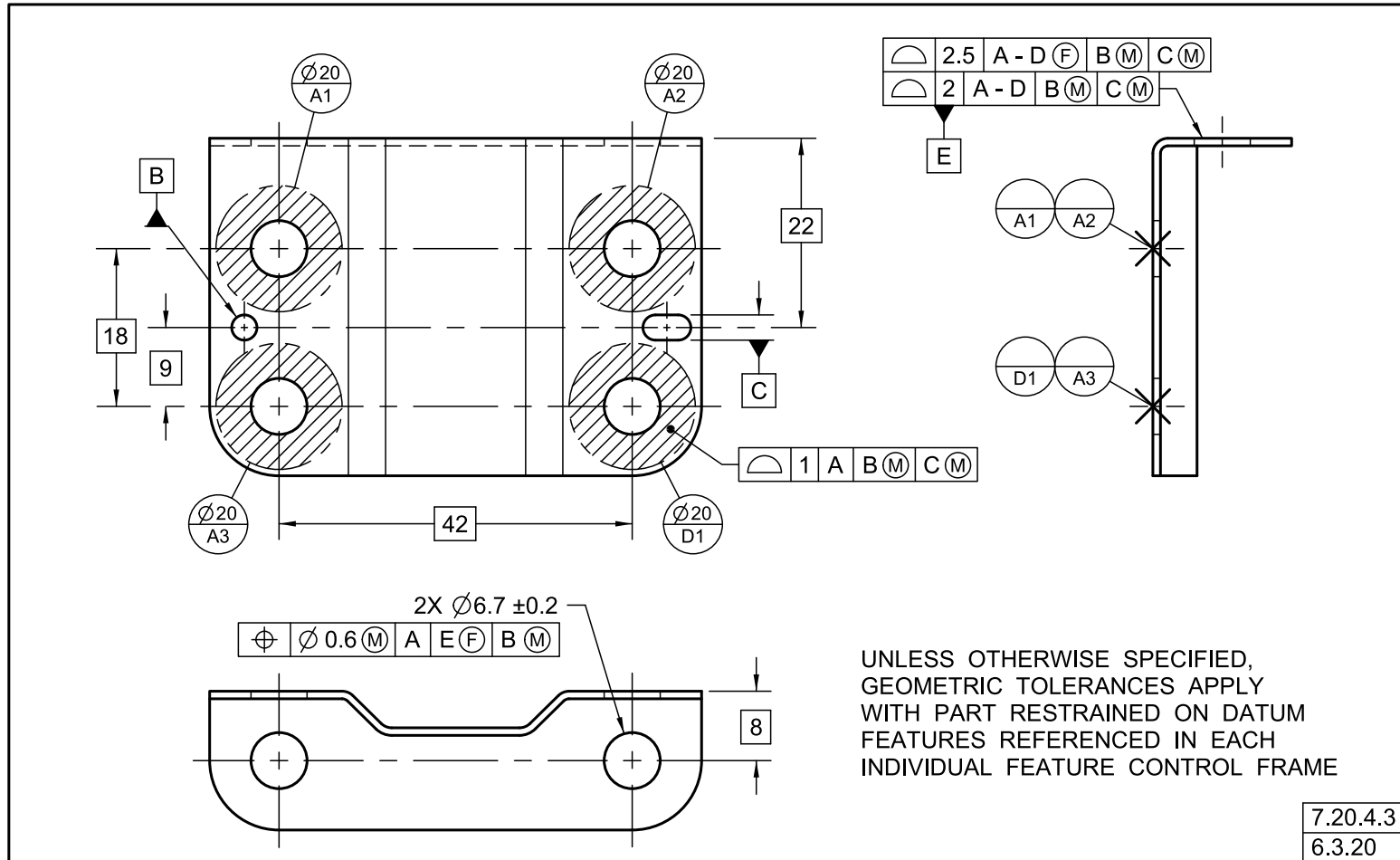

Figure 7-52 Planar Combined Datum Features

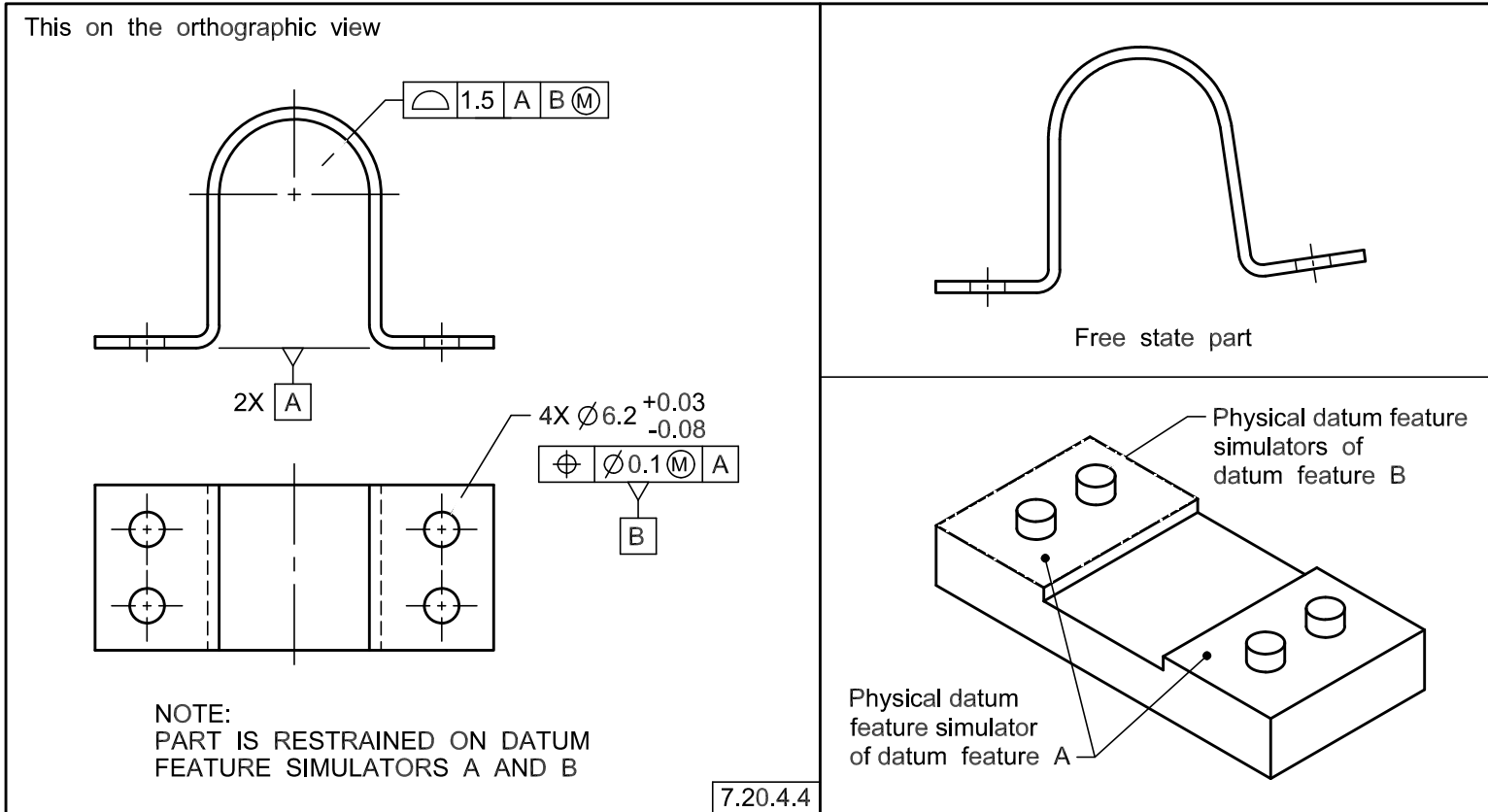
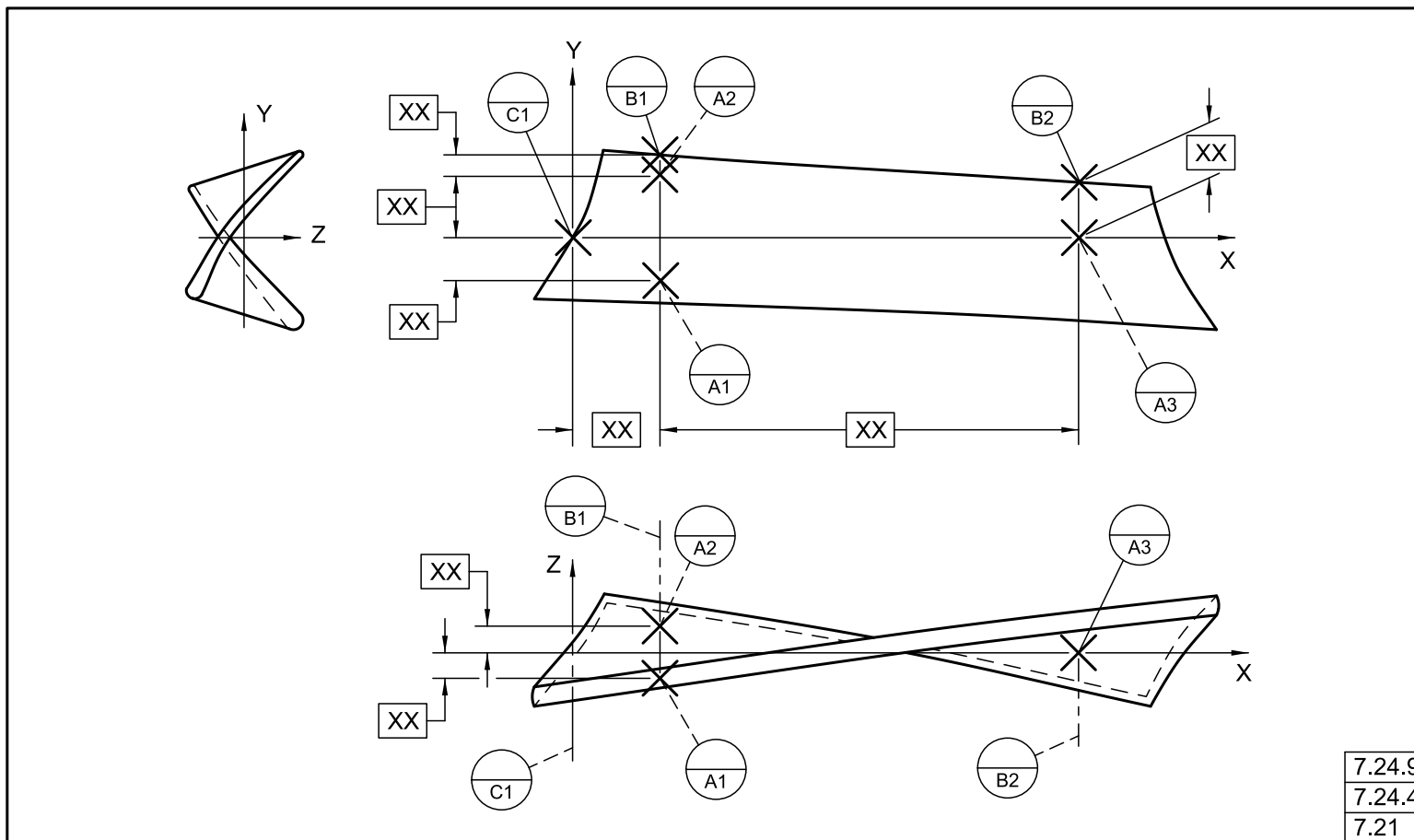

Figure 7-53 Datum Targets Used to Establish Datum Reference Frame for Complex Part



7.24.9
7.24.4
7.21

Figure 7-54 Datum Reference Frame Identification

This on the orthographic views

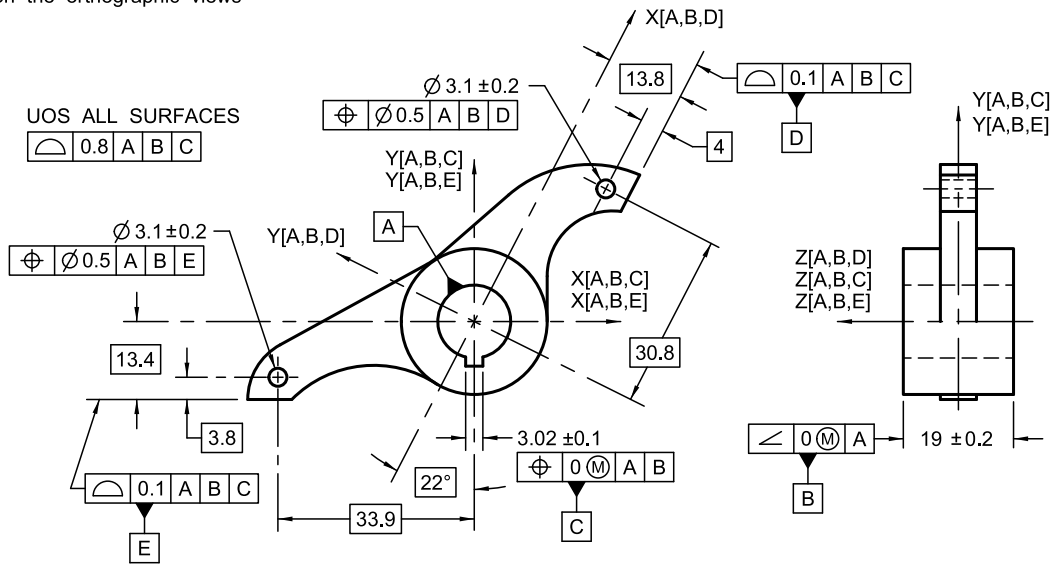

or this on the model

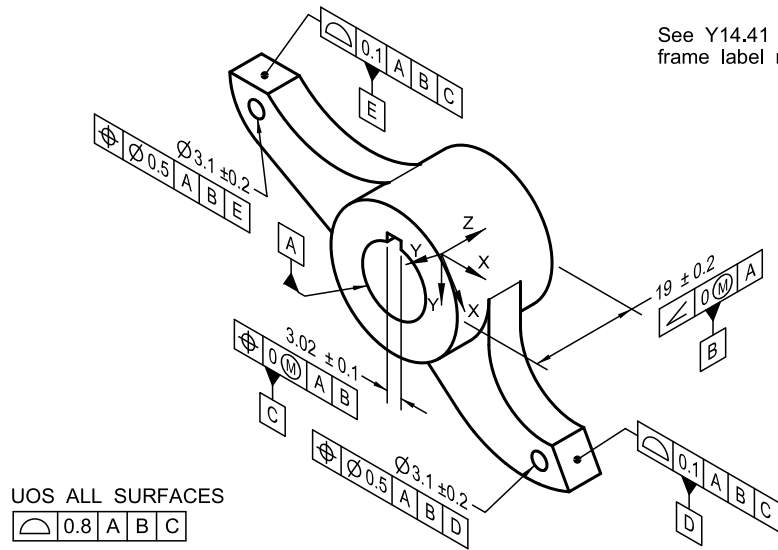

See Y14.41 for datum reference frame label requirements

UOS ALL SURFACES

⊖	0.8	A	B	C
---	-----	---	---	---

Figure 7-55 Conical Datum Feature Referenced to Constrain Five Degrees of Freedom

This on the orthographic views

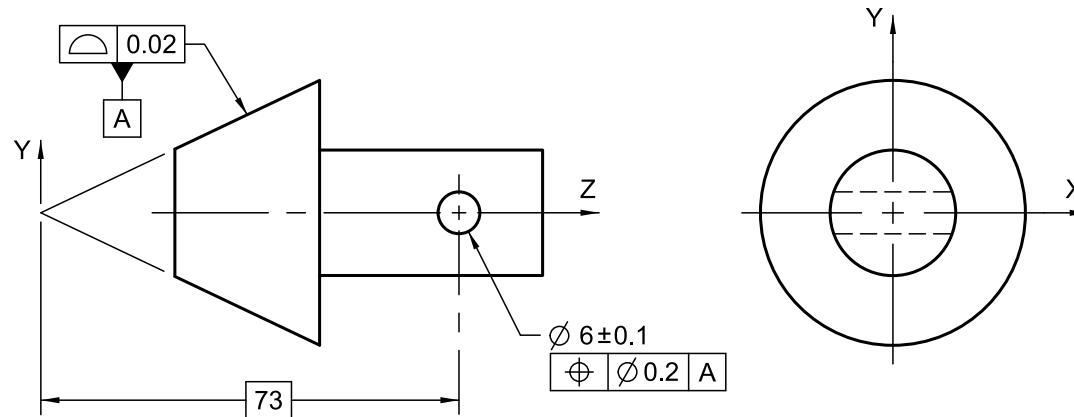

7.23
7.22

Means this

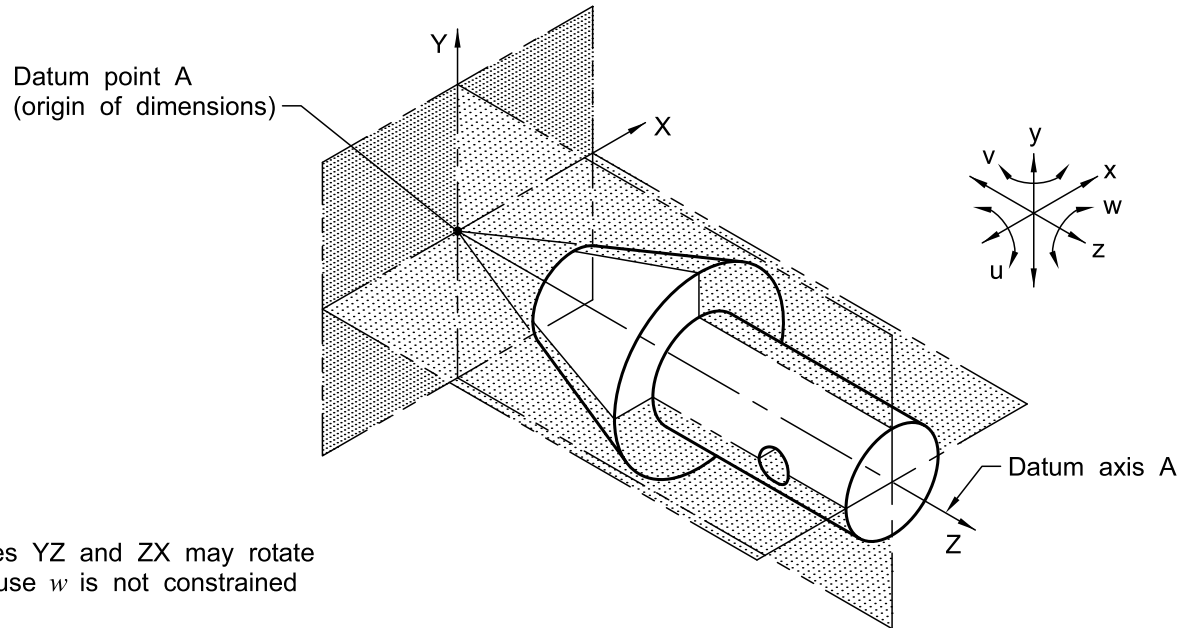

Figure 7-56 Conical Datum Feature Reference Customized to Constrain Four Degrees of Freedom

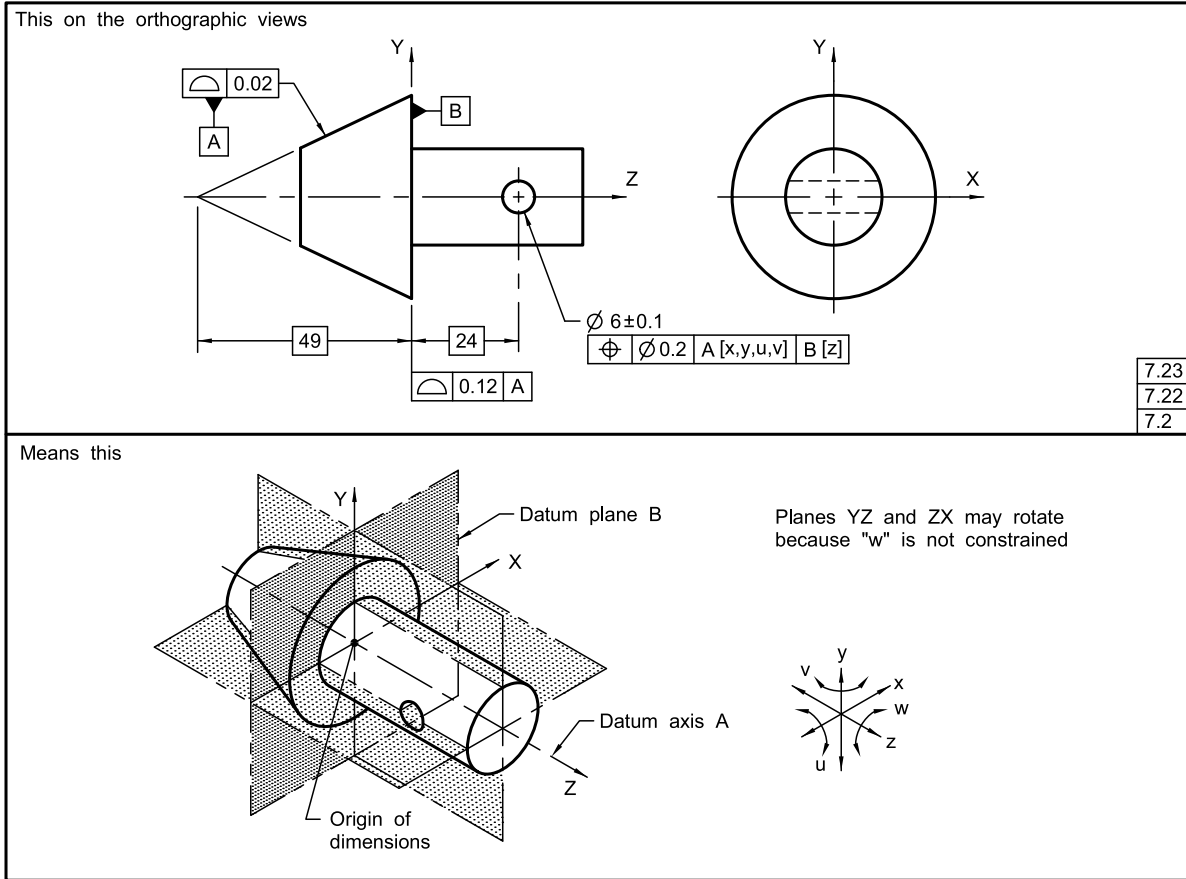
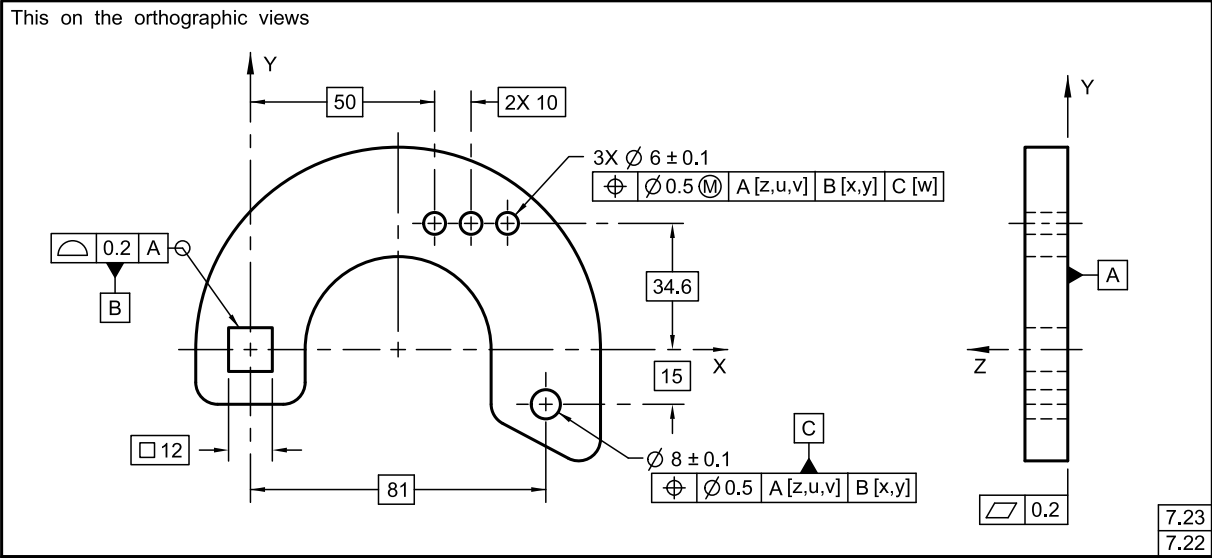

Figure 7-57 Customized Datum Reference Frame



Means this

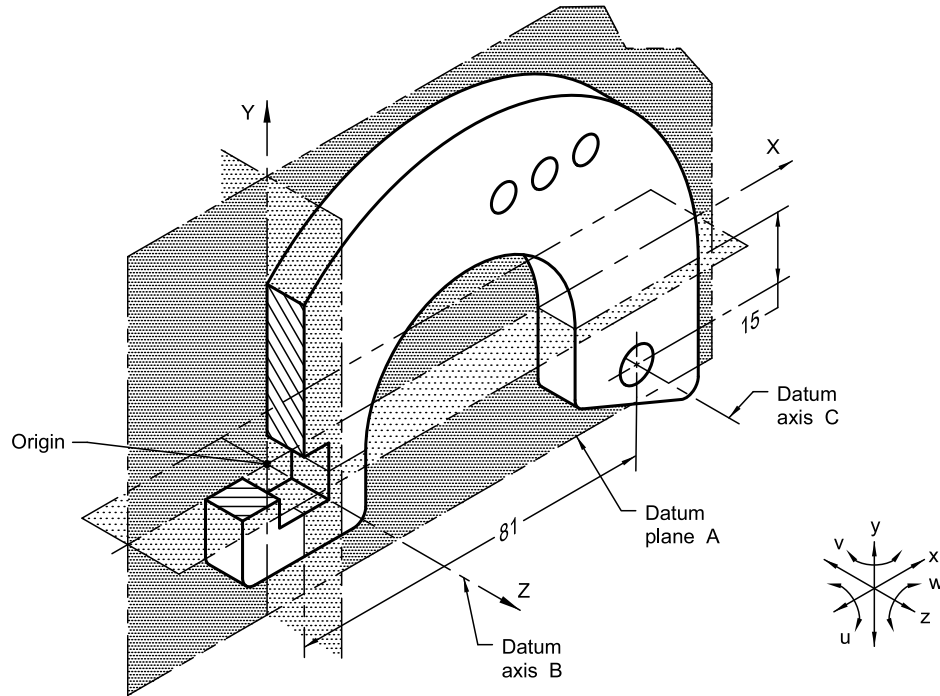

Figure 7-58 Application of Movable Datum Targets

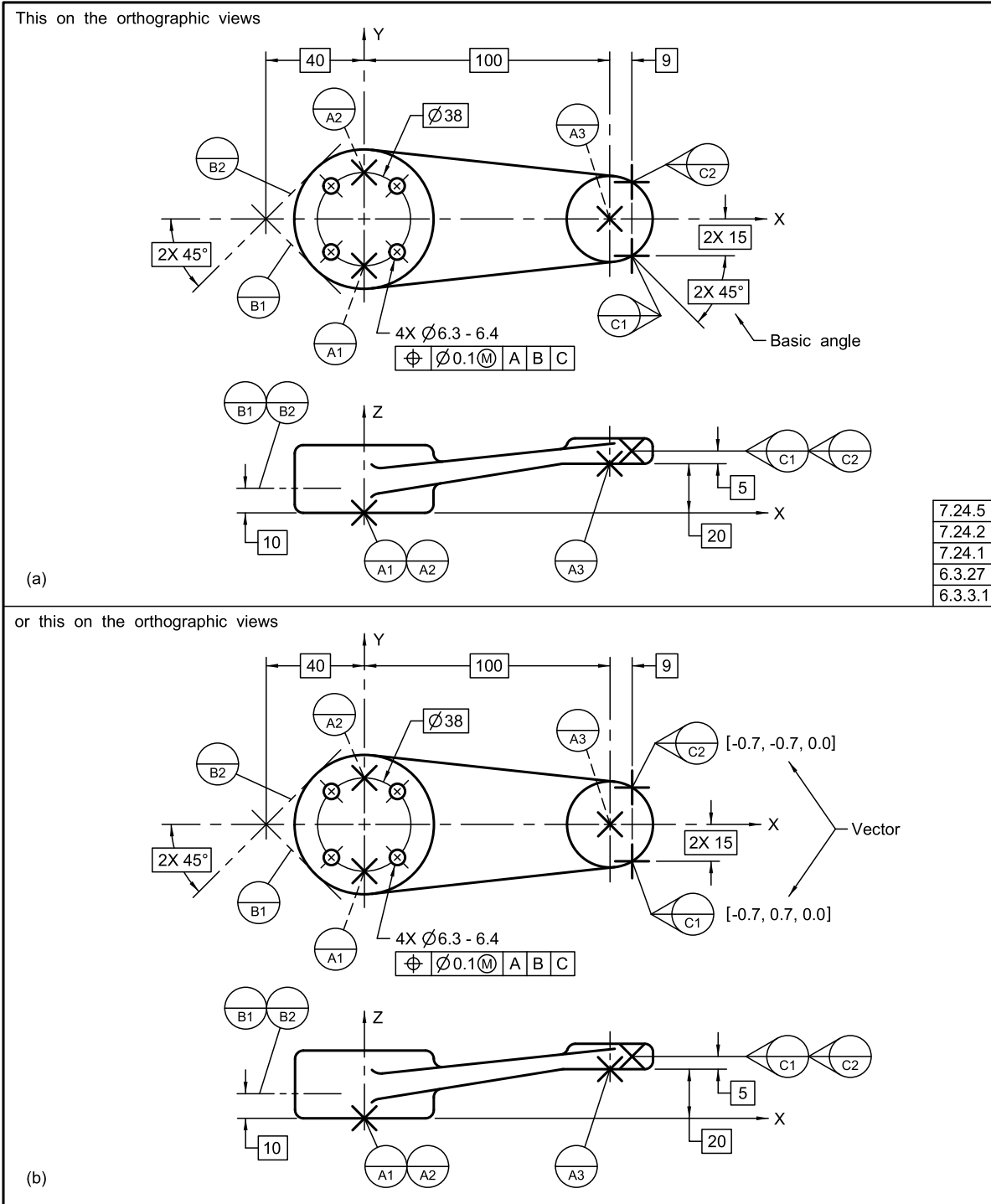

Figure 7-58 Application of Movable Datum Targets (Cont'd)

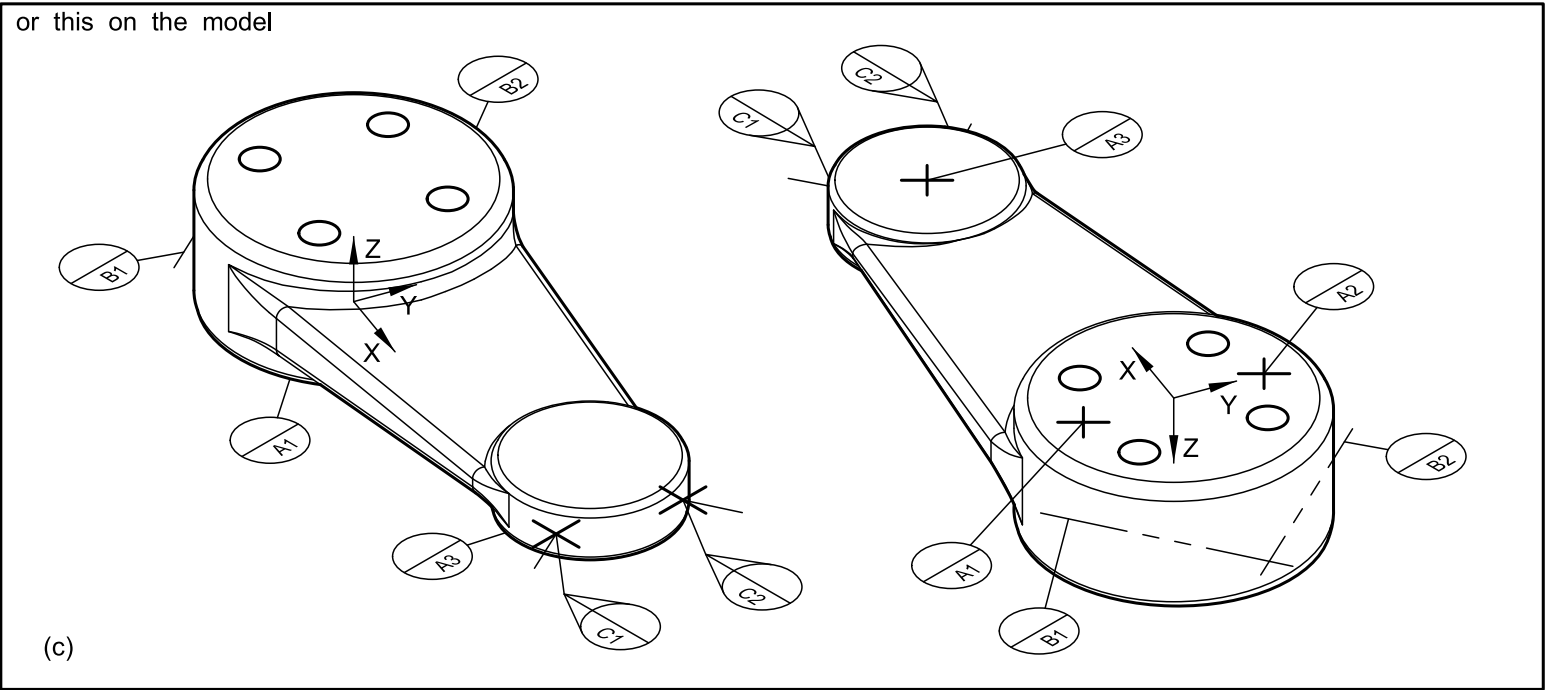
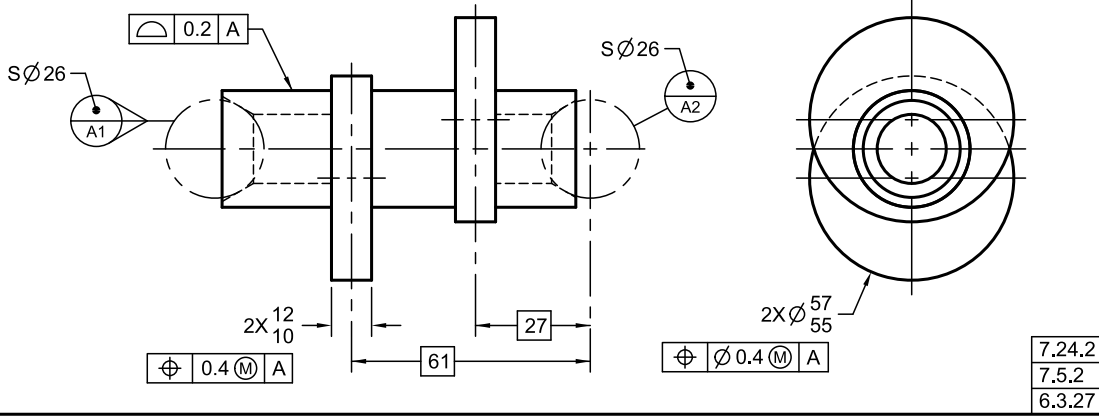

Figure 7-59 Datum Target Spheres

This on the orthographic views



Means this

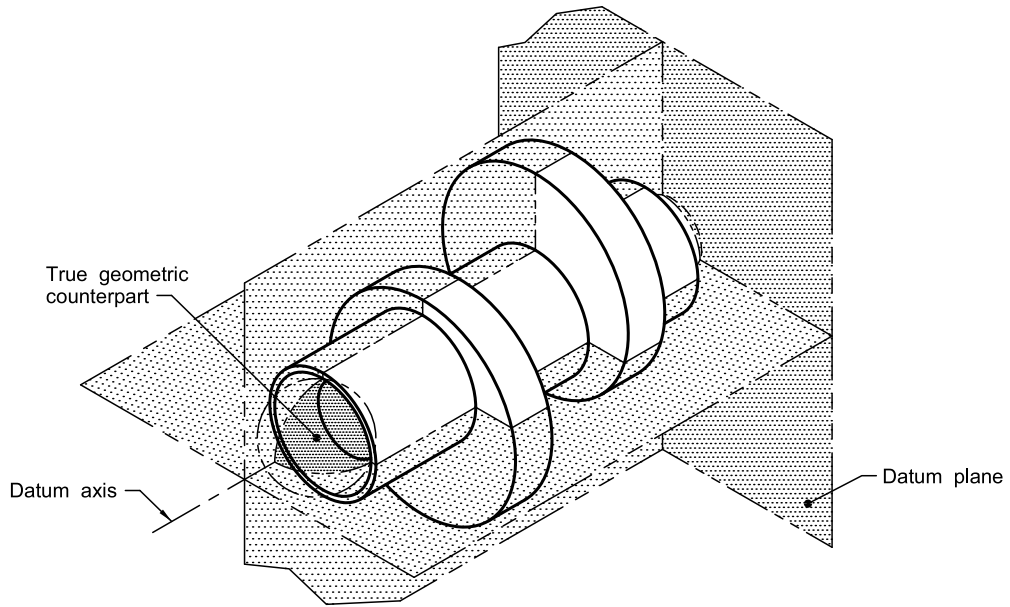
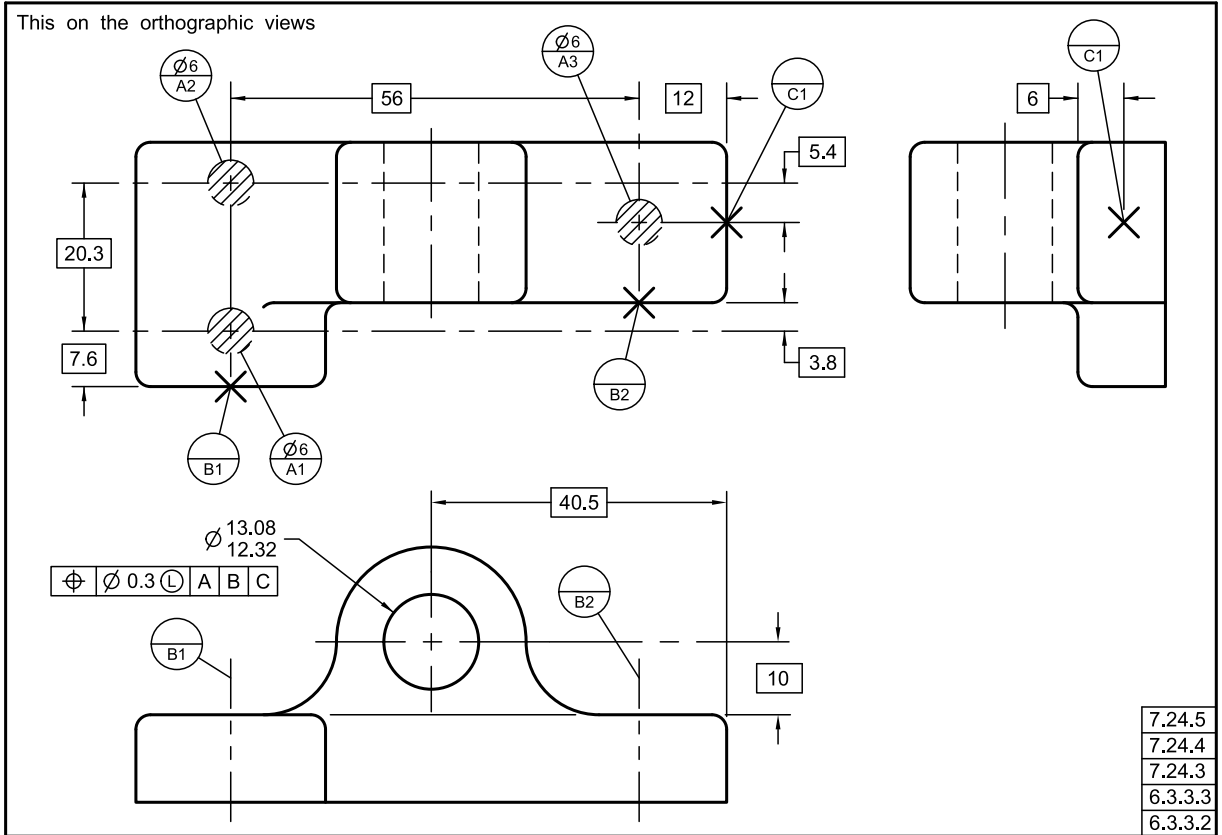

Figure 7-60 Application of Datum Targets to Establish a Datum Reference Frame



Means this

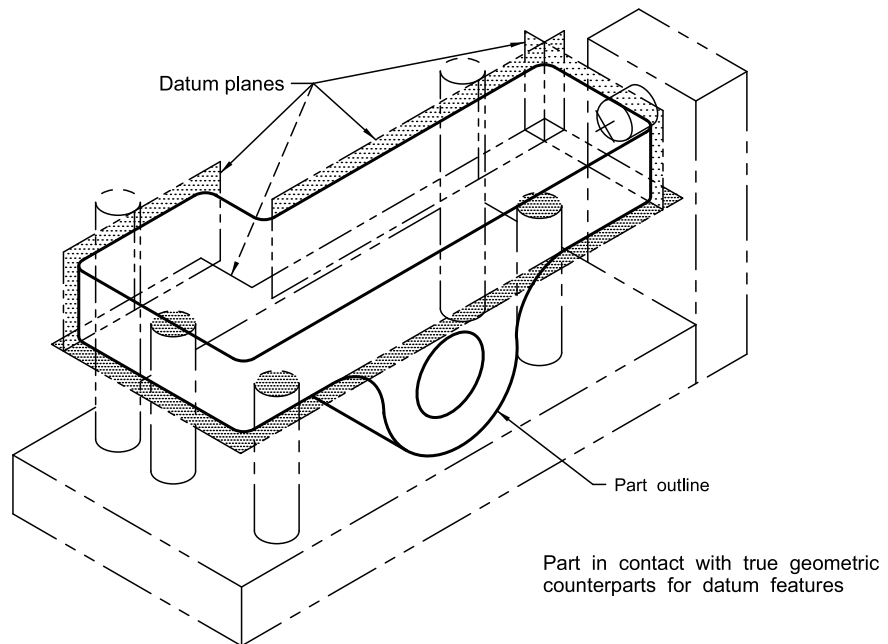
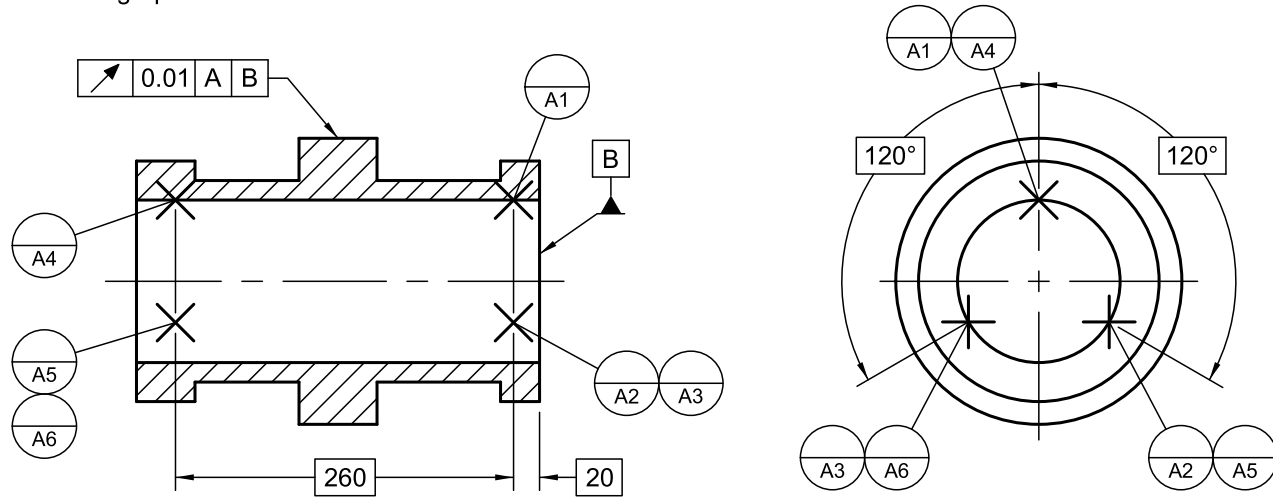
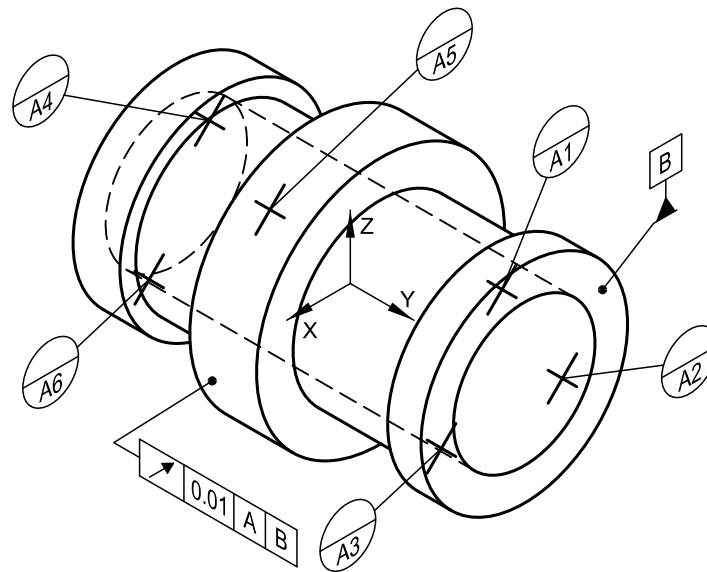

Figure 7-61 Primary Datum Axis Established by Datum Target Points on a Single Cylindrical Feature

This on the orthographic view



Some hidden features are shown for clarity



7.24.6

Figure 7-62 Primary and Secondary Datums Established by Datum Target Lines on Two Cylindrical Features and a Surface

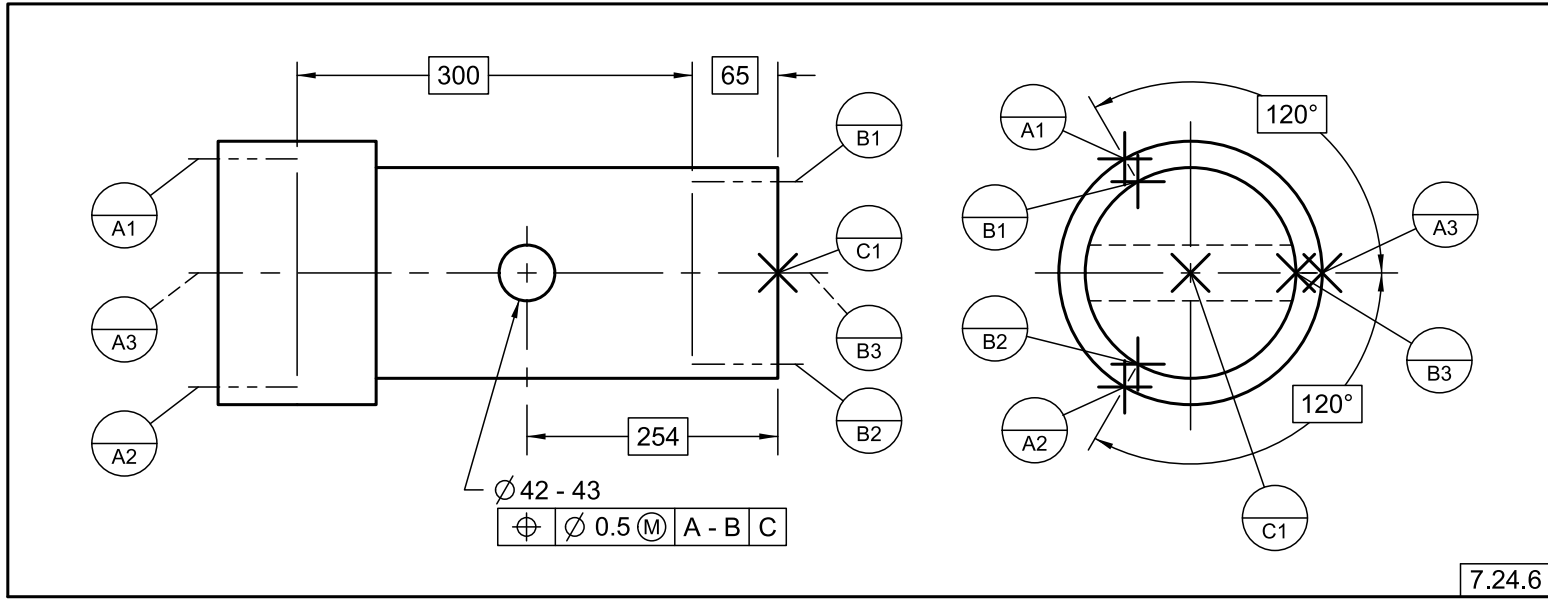

Figure 7-63 Datum Target Line and Area

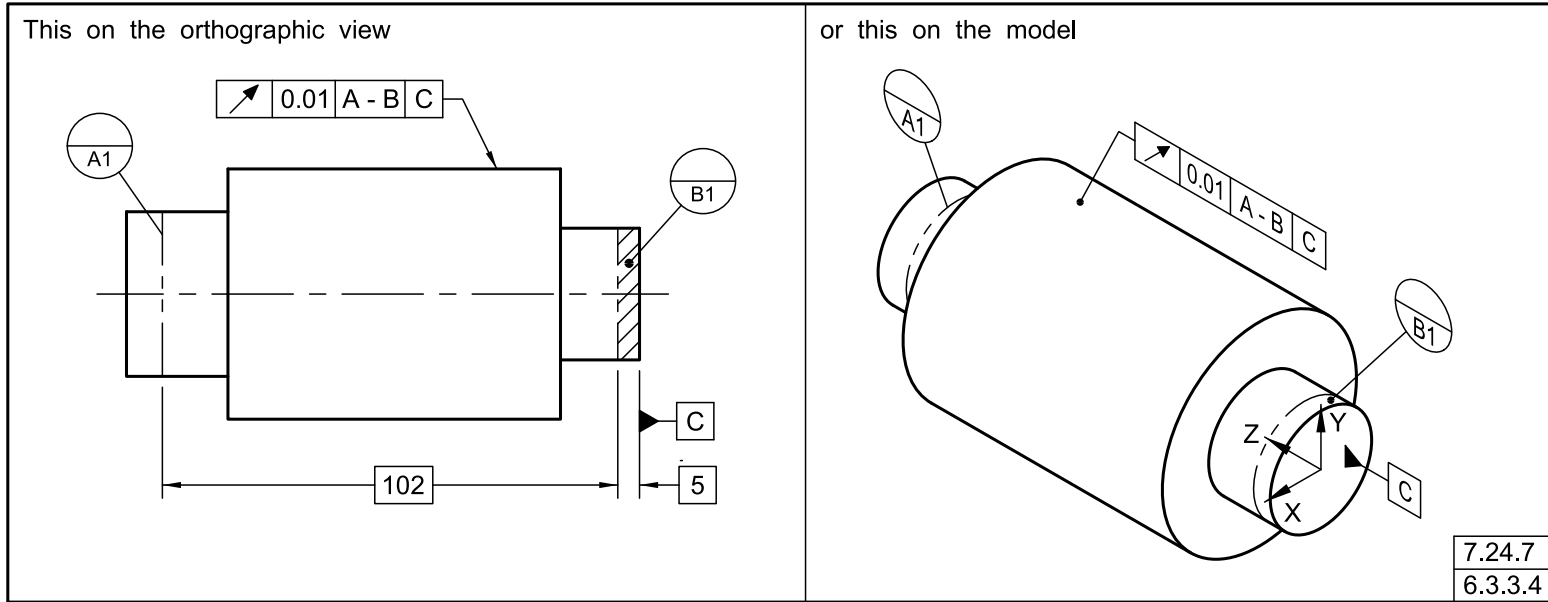
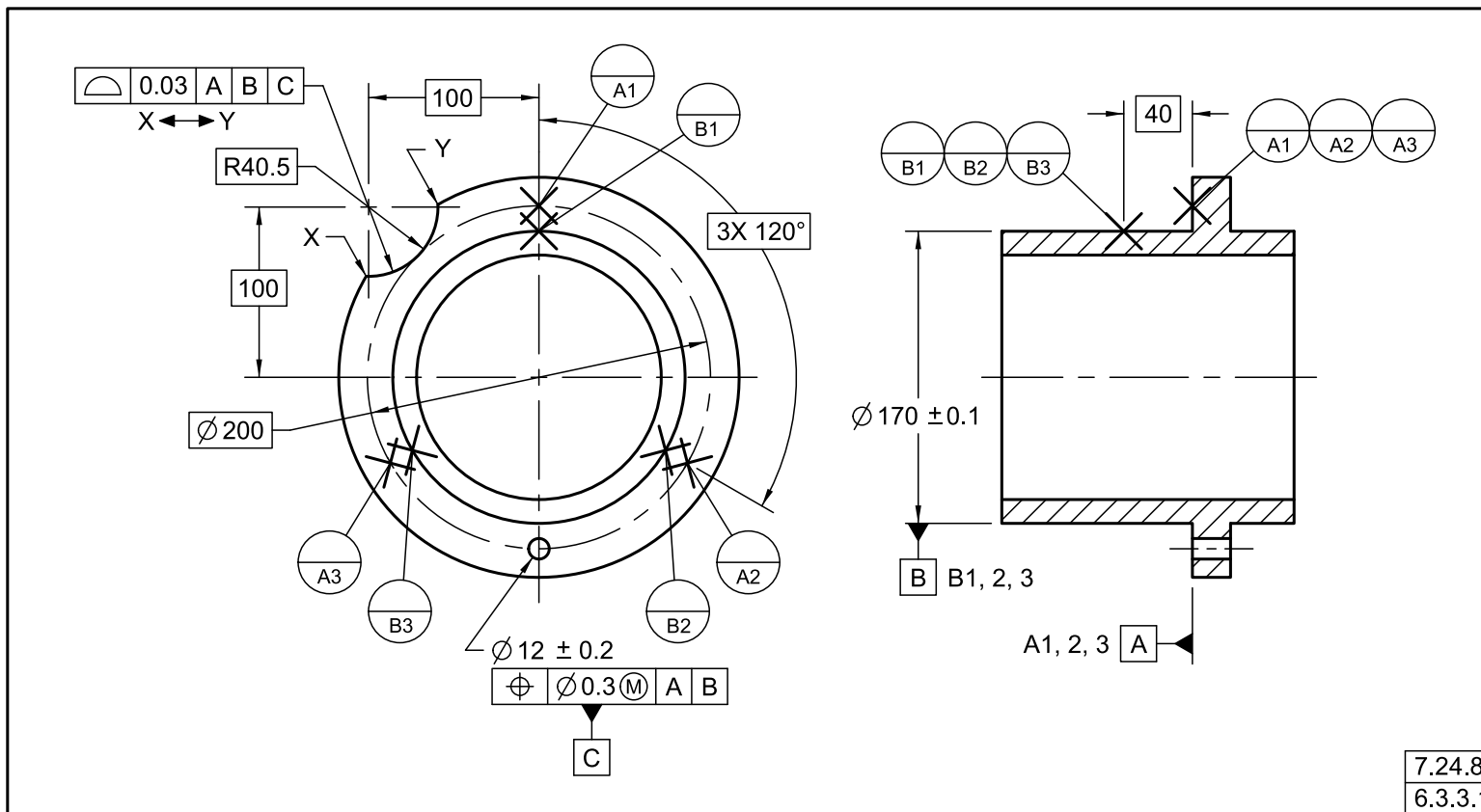

Figure 7-64 Secondary Datum Axis



Section 8

Tolerances of Form

8.1 GENERAL

This Section establishes the principles and methods of dimensioning and tolerancing to control the form of features.

8.2 FORM CONTROL

Form tolerances control straightness, flatness, circularity, and cylindricity. When specifying a form tolerance, consideration shall be given to the control of form already established through other tolerances such as size (Rule #1), orientation, runout, and profile controls. See paras. 5.8 and 5.8.1 and Figure 5-7.

8.3 SPECIFYING FORM TOLERANCES

Form tolerances critical to function or interchangeability are specified where the tolerances of size do not provide sufficient control. A tolerance of form may be specified where no tolerance of size is given, e.g., in the control of flatness after assembly of the parts. A form tolerance specifies a zone within which the considered feature, its line elements, its derived median line, or its derived median plane must be contained.

8.4 FORM TOLERANCES

Form tolerances are applicable to single (individual) features, elements of single features, single features of size, and single features established by the application of the “CF” symbol; therefore, form tolerances are not related to datums. Paragraphs 8.4.1 through 8.4.4 cover the particulars of the form tolerances, i.e., straightness, flatness, circularity, and cylindricity.

8.4.1 Straightness

A straightness tolerance specifies a tolerance zone within which the considered element of a surface or derived median line shall lie. A straightness tolerance is applied in the view where the elements to be controlled are represented by a straight line.

8.4.1.1 Straightness of Line Elements. Figure 8-1 illustrates the use of straightness tolerance on a flat surface. Each line element of the surface shall lie between two parallel lines separated by the amount of the prescribed straightness tolerance and in a direction indicated by the

orthographic view or by supplemental geometry in the model. Straightness may be applied to control line elements in a single direction on a flat surface; it may also be applied in multiple directions. The straightness tolerance shall be less than the size tolerance relative to any opposed surfaces and any other geometric tolerances that affect the straightness of line elements except for those features where the “free state” or the “independency” symbol is applied. Where function requires the line elements to be related to a datum feature(s), the profile of a line shall be specified relative to datums. See Figures 11-33 and 11-34.

8.4.1.2 Straightness of Line Elements on the Surface of Cylindrical Features. Figure 8-2 shows an example of a cylindrical feature in which all circular elements of the surface are to be within the specified size tolerance. Each longitudinal element of the surface shall lie between two parallel lines separated by the amount of the prescribed straightness tolerance and in a plane common with the axis of the unrelated AME of the feature. The feature control frame is attached to a leader directed to the surface or extension line of the surface but not to the size dimension. The straightness tolerance shall be less than the size tolerance and any other geometric tolerances that affect the straightness of line elements except for those features where the “free state” or the “independency” symbol is applied. Since the limits of size must be respected, the full straightness tolerance may not be available for opposing elements in the case of waisting or barreling of the surface. See Figure 8-2.

8.4.1.3 Derived Median Line Straightness. When the feature control frame is associated with the size dimension or attached to an extension of the dimension line of a cylindrical feature, the straightness tolerance applies to the derived median line of the cylindrical feature. A diameter symbol precedes the tolerance value indicating a cylindrical tolerance zone, and the tolerance is applied on an RFS, MMC, or LMC basis. The tolerance value may be greater than the size tolerance; the boundary of perfect form at MMC does not apply. See Figures 8-3 and 8-4. When the straightness tolerance at MMC is used in conjunction with an orientation or position tolerance at MMC, the specified straightness tolerance value shall not be greater than the specified orientation or position

tolerance value and does not contribute to the IB or OB of the position or orientation tolerance. The collective effect of the MMC size and form tolerance produces a VC, OB, or IB resulting from the form tolerance but does not affect the IB or OB created by any orientation or position tolerances on the feature. See [Figure 7-22](#).

When applied on an MMC basis, as in [Figure 8-4](#), the maximum straightness tolerance is the specified tolerance plus the amount the actual local size of the feature departs from its MMC size. The derived median line of the actual feature at MMC shall be within a cylindrical tolerance zone as specified. As each actual local size departs from MMC, an increase in the local diameter of the tolerance zone is allowed that is equal to the amount of this departure. Each circular element of the surface (i.e., actual local size) shall be within the specified limits of size.

When applied RFS, as in [Figure 8-3](#), the maximum straightness tolerance is the specified tolerance. The derived median line of the actual feature RFS shall be within a cylindrical tolerance zone as specified. When the straightness tolerance RFS is used in conjunction with an orientation tolerance RFS or position tolerance RFS, the specified straightness tolerance value combines with the specified orientation or position tolerance value and contributes to the IB or OB of the position or orientation tolerance.

8.4.1.4 Applied on a Unit Basis. Straightness may be applied on a unit basis as a means of limiting an abrupt surface variation within a relatively short length of the feature. See [Figure 8-5](#). When using unit control on a feature of size, a maximum limit is typically specified to limit the relatively large theoretical variations that may result if left unrestricted. If the unit variation appears as a “bow” in the toleranced feature, and the bow is allowed to continue at the same rate for several units, the overall tolerance variation may result in an unsatisfactory part. [Figure 8-6](#) illustrates the possible condition in which straightness per unit length given in [Figure 8-5](#) is used alone, i.e., if straightness for the total length is not specified. A multiple-segment feature control frame showing one symbol or multiple single segments may be used. See [para. 8.4.2.2](#).

8.4.2 Flatness

A flatness tolerance specifies a tolerance zone defined by two parallel planes within which the surface or derived median plane shall lie. When a flatness tolerance is specified on a surface, the feature control frame is attached to a leader directed to the surface or to an extension line of the surface. See [Figure 8-7](#). With flatness of a surface, where the considered surface is associated with a size dimension, the flatness tolerance shall be less than the size tolerance except for those features to which the “free state” or “independency” symbol is applied. When the “independency” symbol is applied to the size dimension, the requirement

for perfect form at MMC is removed and the form tolerance may be larger than the size tolerance.

8.4.2.1 Application of Flatness RFS, MMC, or LMC to Width. Flatness may be applied on an RFS, MMC, or LMC basis to width features of size, and the tolerance value may be greater than the size tolerance; the boundary of perfect form at MMC does not apply. In this instance, the derived median plane shall lie in a tolerance zone between two parallel planes separated by the amount of the tolerance. Feature control frame placement and arrangement as described in [para. 8.4.1.3](#) apply, except the diameter symbol is not used, since the tolerance zone is a width. See [Figures 8-8](#) and [8-9](#).

8.4.2.2 Applied on a Unit Basis. Flatness may be applied on a unit basis as a means of limiting an abrupt surface variation within a relatively small area of the feature. The unit variation is used either in combination with a specified total variation or alone. Caution should be exercised when using unit control alone for the reasons given in [para. 8.4.1.4](#). Since flatness involves surface area, the size of the unit area, e.g., a square area “25 X 25” or a circular area “25” in diameter, is specified to the right of the flatness tolerance, separated by a slash. A multiple-segment feature control frame may be used showing one symbol (as illustrated in the figures below) or multiple single-segment frames may be used, as in the following examples:

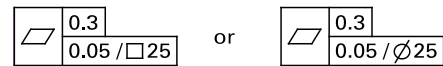

8.4.3 Circularity (Roundness)

A circularity tolerance specifies a tolerance zone bounded by two concentric circles within which each circular element of the surface shall lie, and applies independently at any plane described in [paras. 3.6\(a\)](#) and [3.6\(b\)](#). See [Figures 8-10](#) and [8-11](#). A callout for circularity shall be specified on a surface and not to a size dimension. The circularity tolerance shall be less than the size tolerance and other geometric tolerances that affect the circularity of the feature, except for those features where Rule #1 does not apply (e.g., “free state” symbol, average diameter, “independency” symbol). See subsection [8.5](#).

NOTE: See ANSI B89.3.1 and ASME Y14.5.1M for further information on this subject.

8.4.4 Cylindricity

A cylindricity tolerance specifies a tolerance zone bounded by two concentric cylinders. The surface shall be within these two concentric cylinders. In the case of cylindricity, unlike that of circularity, the tolerance applies simultaneously to both circular and longitudinal elements of the surface (the entire surface). See [Figure 8-12](#). When shown in

orthographic views, the leader from the feature control frame may be directed to either view. The cylindricity tolerance shall be less than the size tolerance except for those features where the “free state” or “independency” symbol is applied. A callout for cylindricity shall be specified on a surface and not to a size dimension. Cylindricity may be applied on a unit basis as a means of limiting an abrupt surface variation within a relatively short length of the feature.

NOTE: The cylindricity tolerance is a composite control of form that includes circularity, straightness, and taper of a cylindrical feature.

8.5 AVERAGE DIAMETER

An average diameter is the average of several diametric measurements across a circular or cylindrical feature. The individual measurements may violate the limits of size, but the average value shall be within the limits of size. Typically, an average diameter is specified for parts that are

flexible in a nonrestrained condition; however, its application is not limited to such cases. Enough measurements (at least four) should be taken to ensure the establishment of an average diameter. If practical, an average diameter may be determined by a peripheral or circumferential measurement. The pertinent diameter is qualified with the abbreviation “AVG.” See [Figures 8-13](#) and [8-14](#). Specifying circularity on the basis of an average diameter may be necessary to ensure that the actual diameter of the feature can conform to the desired shape at assembly. Note that the circularity tolerance can be greater than the size tolerance on the diameter. Invoking average diameter constitutes an exception to Rule #1 for the size tolerance; see [para. 5.8.2](#). [Figure 8-13](#), illustrations (a) and (b) (simplified by showing only two measurements) show the permissible diameters in the free state for two extreme conditions of maximum average diameter and minimum average diameter, respectively. The same method applies when the average diameter is anywhere between the maximum and minimum limits.

Figure 8-1 Specifying Straightness of a Flat Surface

This on the orthographic views

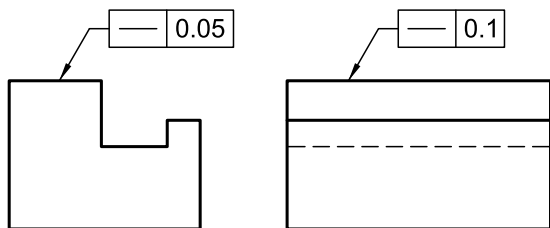

Means this

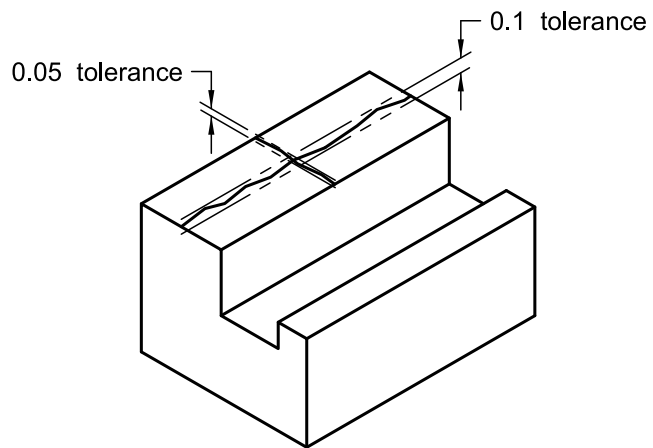

Each longitudinal element of the surface shall be within two parallel lines 0.05 apart in the left view and 0.1 in the right view of the drawing.

or this on the model

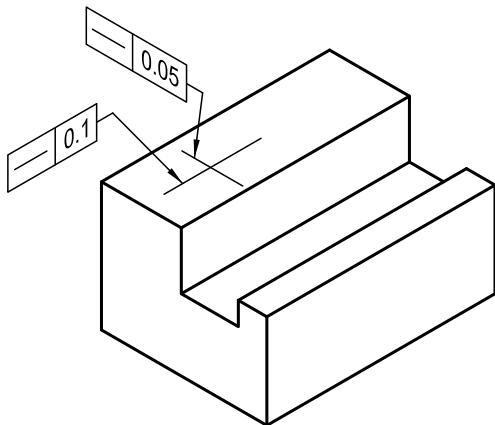

8.4.1.1

Figure 8-2 Specifying Straightness of Surface Elements

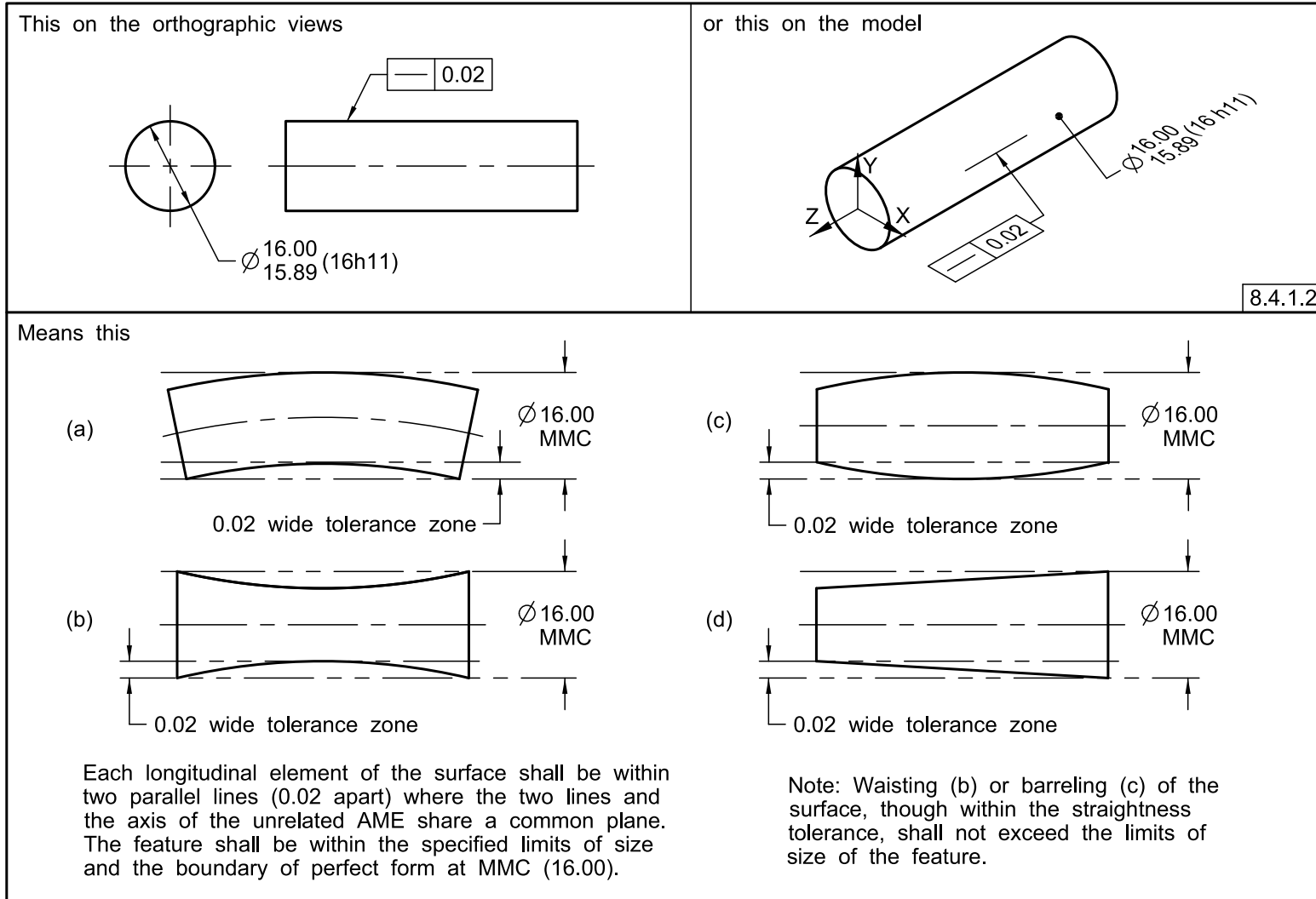

Figure 8-3 Specifying Straightness RFS

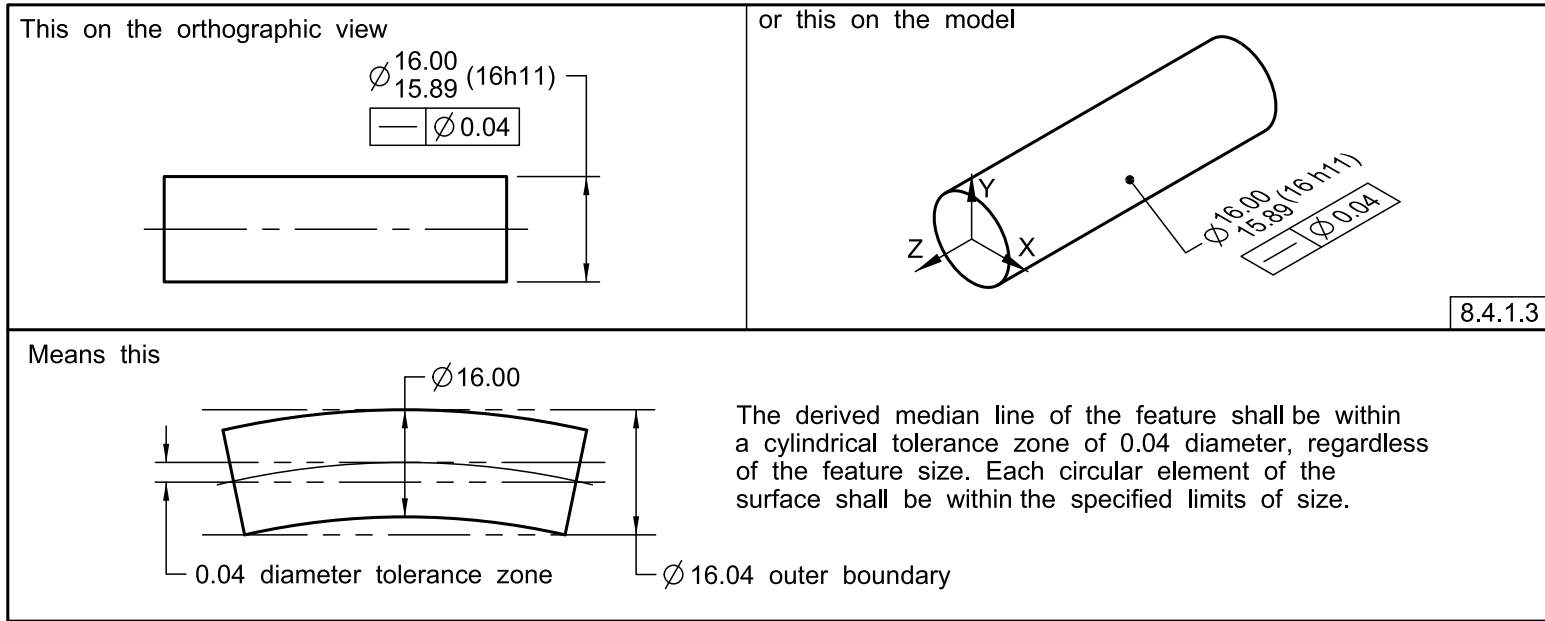

Figure 8-4 Specifying Straightness at MMC

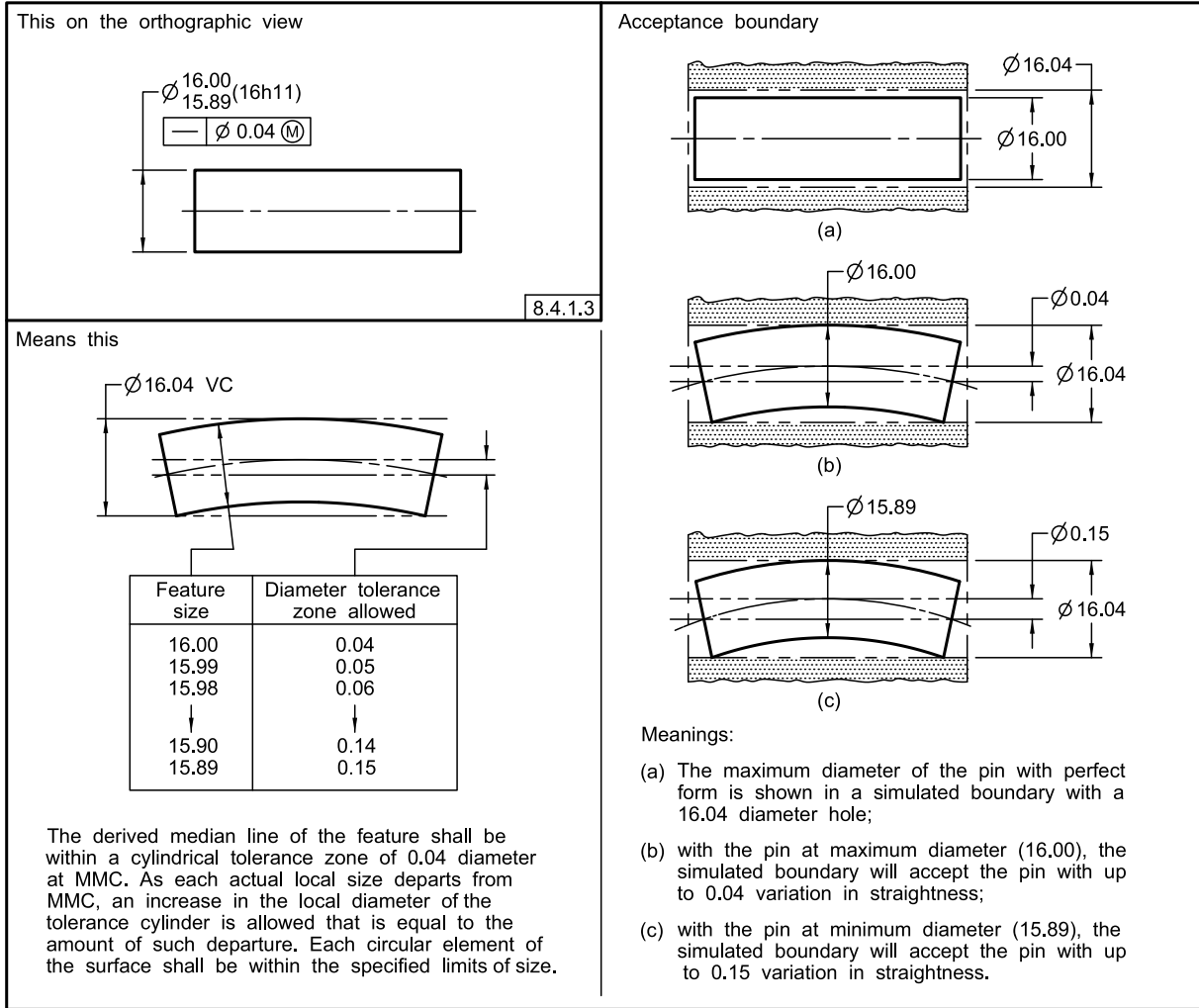
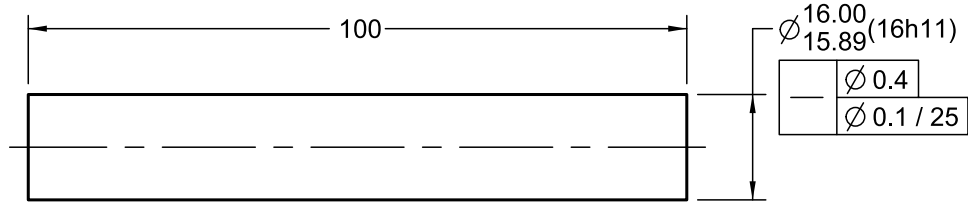

Figure 8-5 Specifying Straightness per Unit Length With Specified Total Straightness, Both RFS

This on the orthographic view



8.4.1.4

Means this

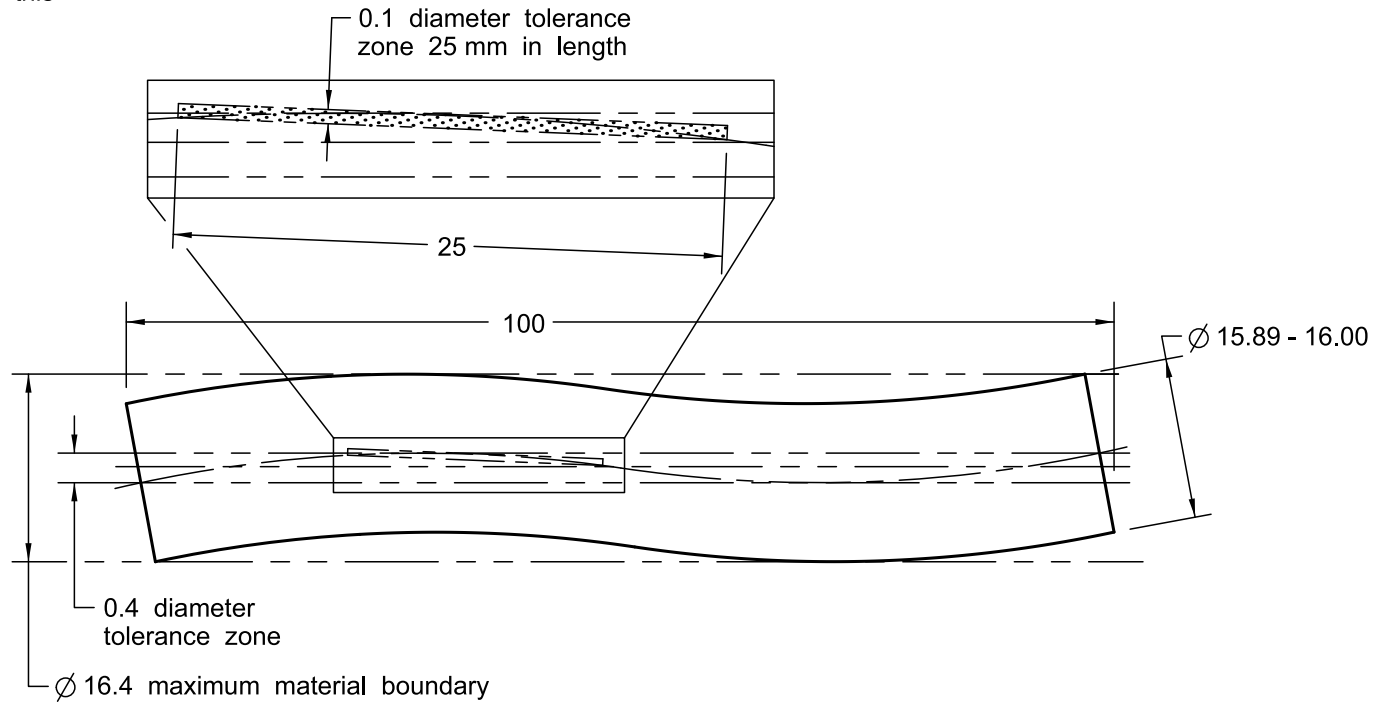

The derived median line of the feature shall be within a cylindrical tolerance zone of 0.4 diameter for the total 100 mm of length and within a 0.1 diameter cylindrical tolerance zone for any 25 mm in length at any location, RFS. Each circular element of the surface shall be within the specified limits of size.

Figure 8-6 Possible Results of Specifying Straightness per Unit Length RFS, With No Specified Total

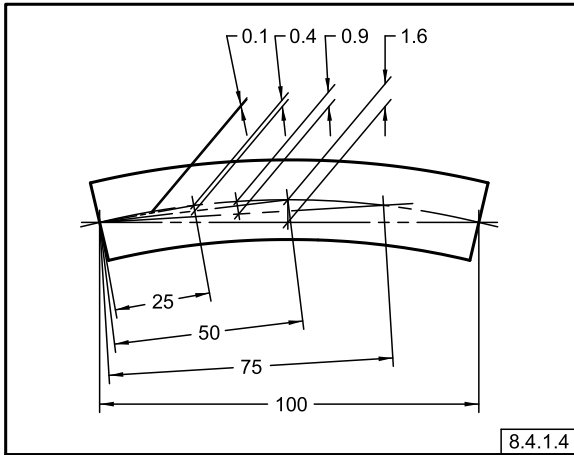

Figure 8-7 Specifying Flatness of a Surface

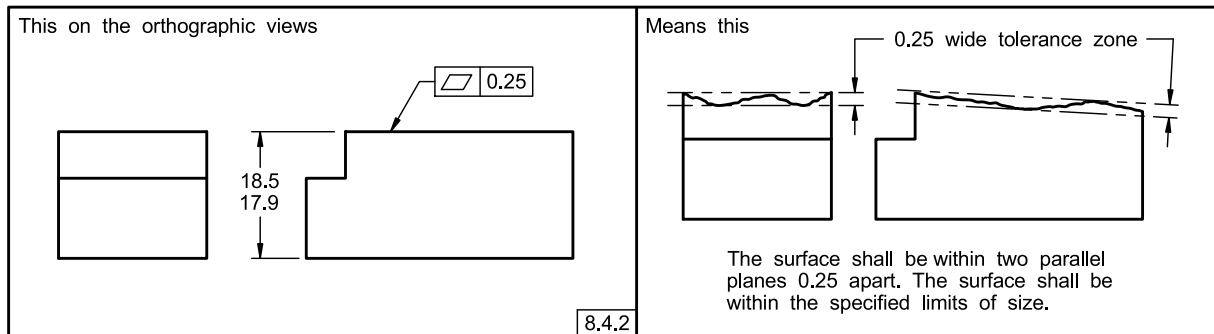

Figure 8-8 Specifying Flatness of a Derived Median Plane RFS

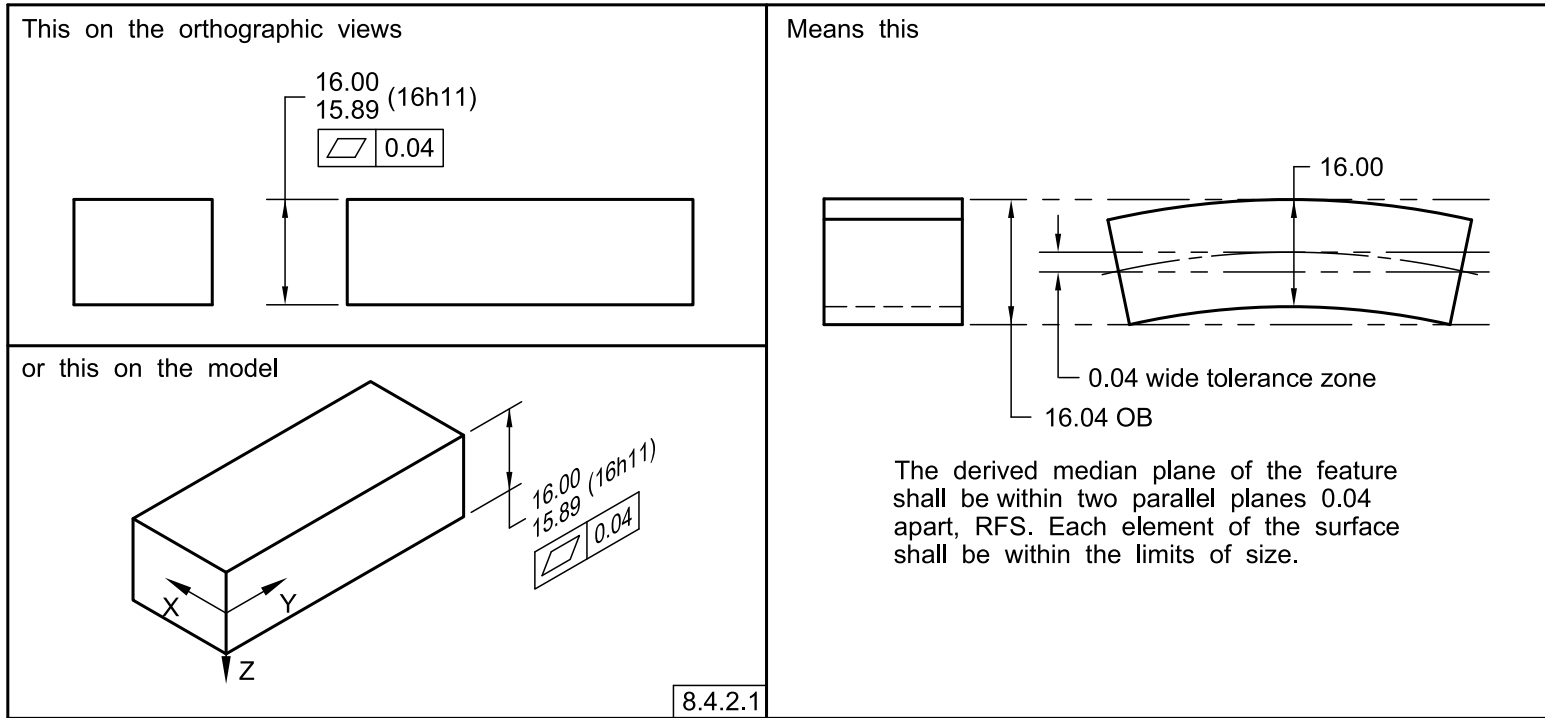

Figure 8-9 Specifying Flatness of a Derived Median Plane at MMC

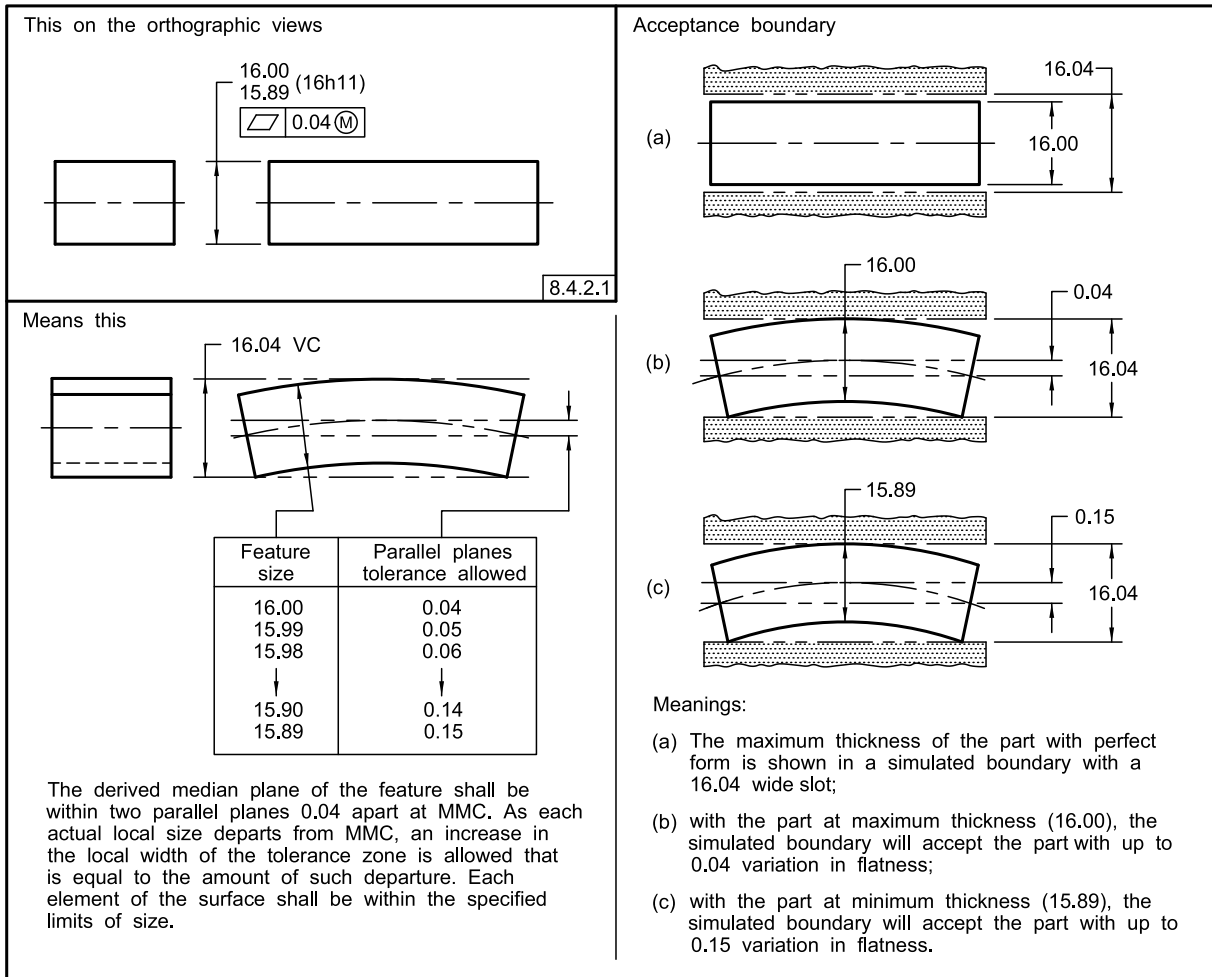
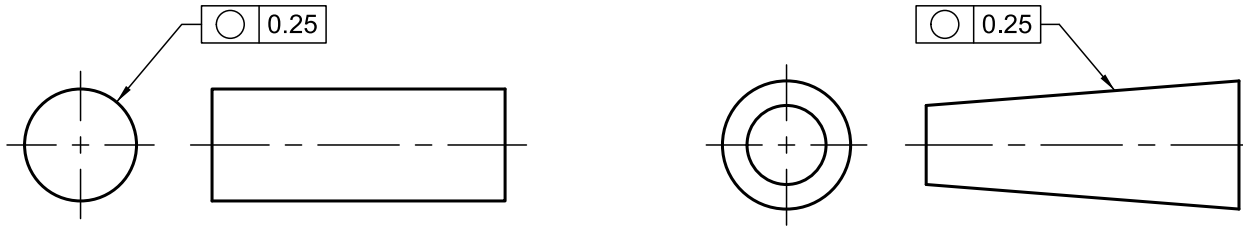
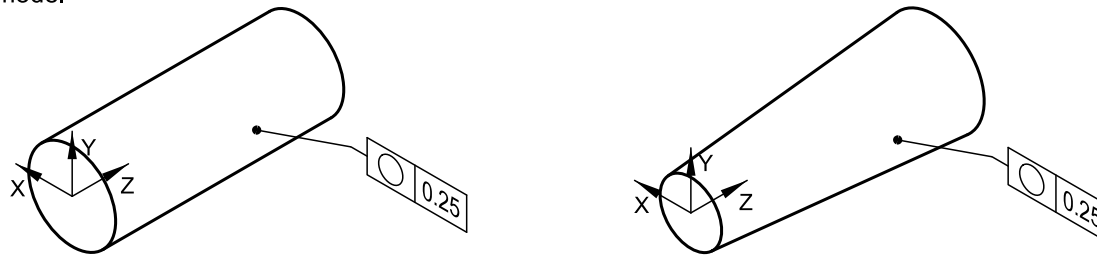

Figure 8-10 Specifying Circularity for a Cylinder or Cone

This on the orthographic views



or this on the model



8.4.3

Means this

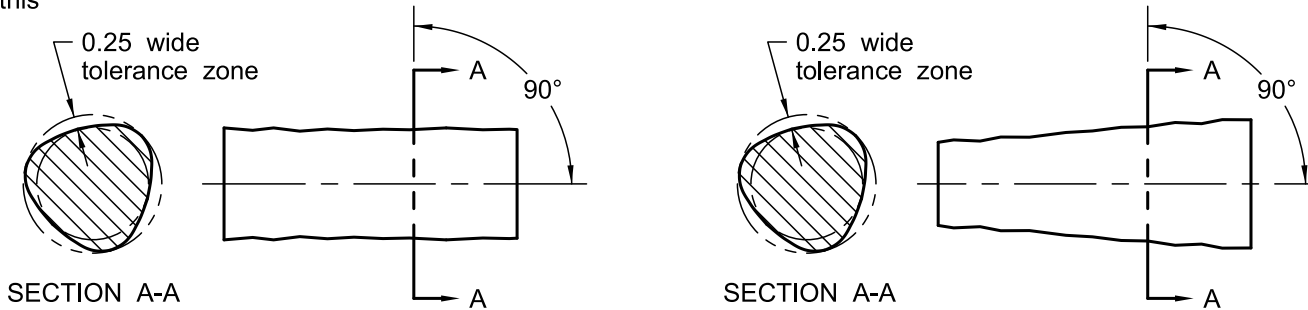

Each circular element of the surface in a plane perpendicular to the axis of the unrelated AME shall be within two concentric circles, one having a radius 0.25 larger than the other. Each circular element of the surface shall be within the specified limits of size.

Figure 8-11 Specifying Circularity of a Sphere

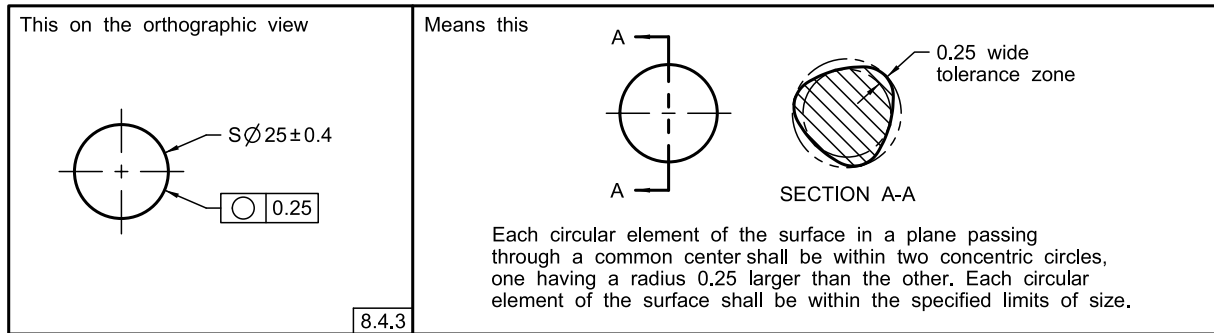

Figure 8-12 Specifying Cylindricity

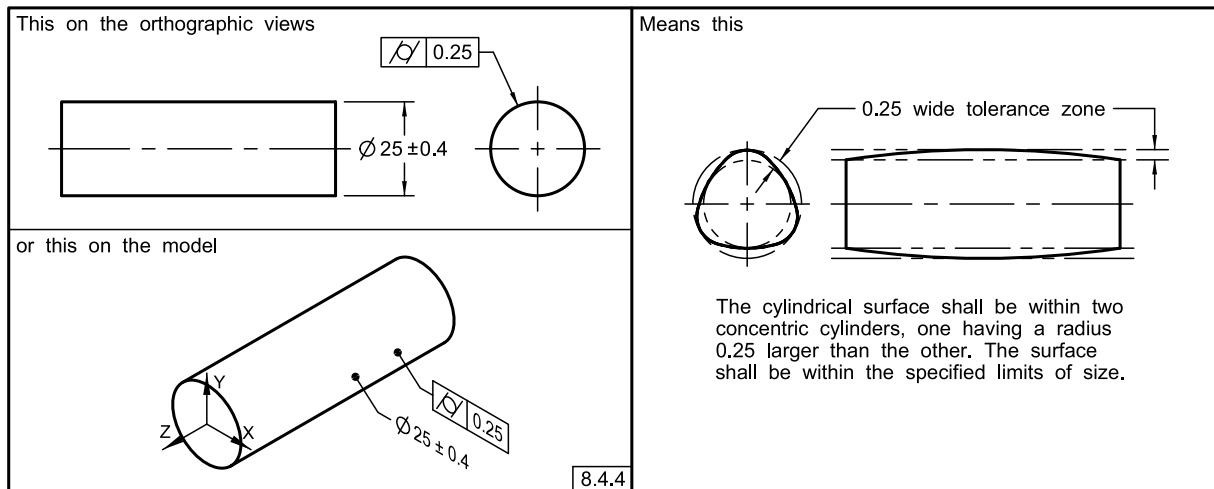

Figure 8-13 Specifying Circularity With Average Diameter

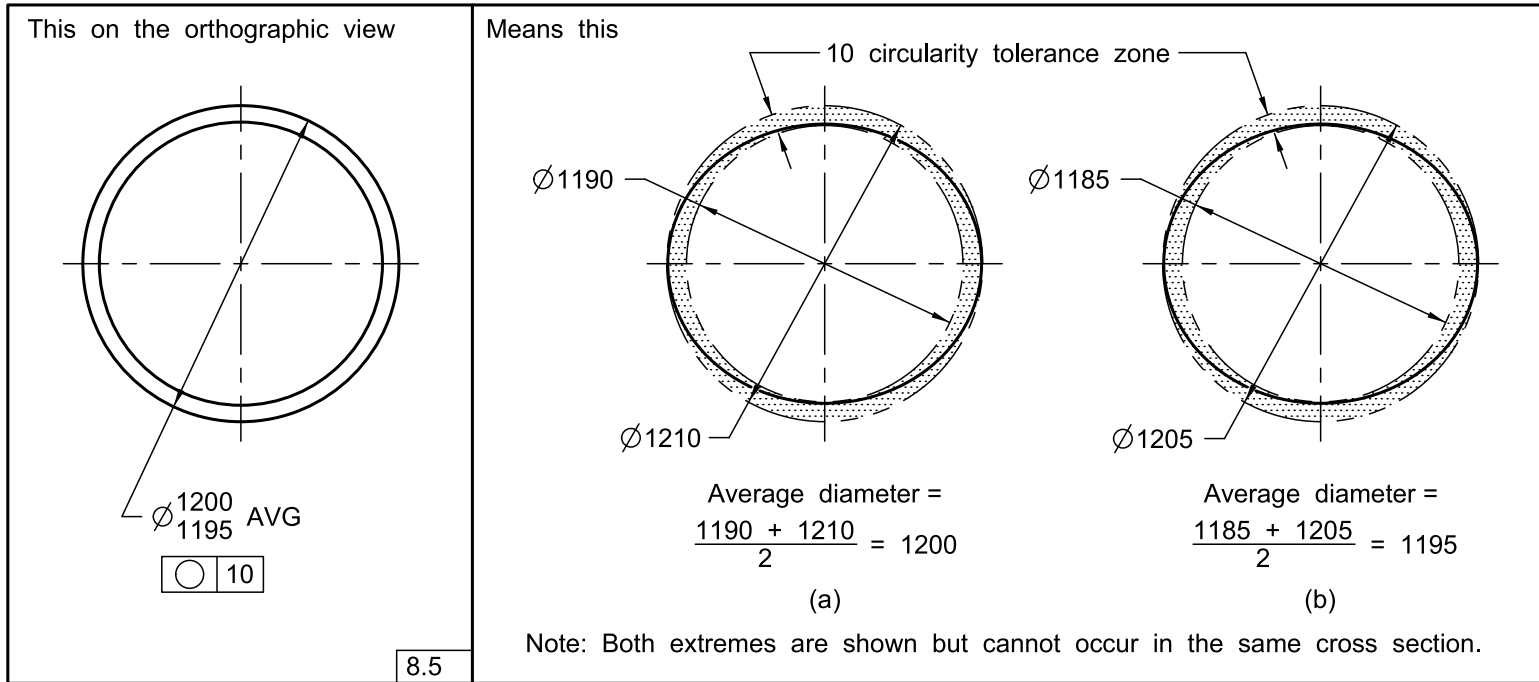
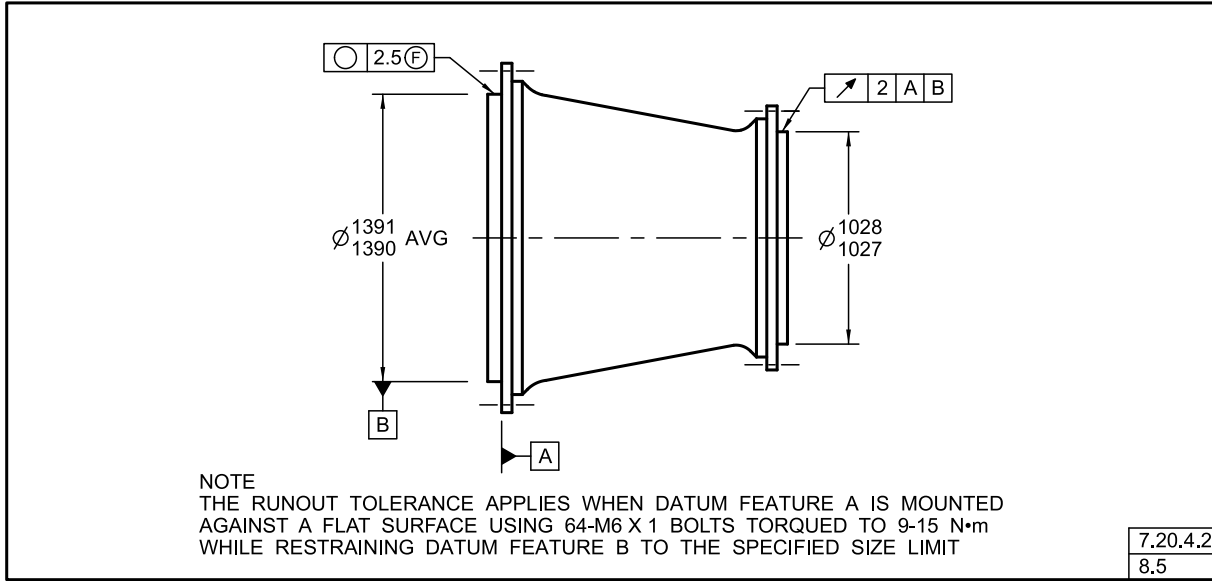

Figure 8-14 Specifying Restraint for Nonrigid Parts



Section 9

Tolerances of Orientation

9.1 GENERAL

This Section establishes the principles and methods of dimensioning and tolerancing to control orientation of features.

9.2 ORIENTATION CONTROL

Orientation tolerances control angularity, parallelism, and perpendicularity, i.e., all angular relationships. Note that an orientation tolerance, when applied to a plane surface, controls flatness to the extent of the orientation tolerance unless the tangent plane symbol is added. When the flatness control in the orientation tolerance is not sufficient, a separate flatness tolerance should be considered. See [Figure 7-15](#). An orientation tolerance does not control the location of features. When specifying an orientation tolerance, consideration should be given to the control of orientation already established through other tolerances, such as position, runout, and profile controls. See [Figures 10-8](#) and [10-9](#).

9.3 SPECIFYING ORIENTATION TOLERANCES

When specifying an orientation tolerance, the tolerance zone shall be related to one or more datums. See [Figures 7-15](#) and [9-4](#). Orientation tolerances are constrained only in rotational degrees of freedom relative to the referenced datums; they are not constrained in translational degrees of freedom. Thus, with orientation tolerances, even in those instances where datum features may constrain all degrees of freedom, the tolerance zone only orients to that datum reference frame. Sufficient datum features shall be referenced to constrain the required rotational degrees of freedom. If the primary datum feature alone does not constrain sufficient degrees of freedom, additional datum features shall be specified.

An angularity tolerance may be applied to a surface, center plane, or axis that is an implied 0° (parallel), implied 90° (perpendicular), or other basic angle from one or more datum planes or datum axes.

9.3.1 Orientation Tolerance Zone

An orientation tolerance specifies a zone within which the considered feature, its line elements, its axis, or its center plane shall be contained.

9.3.2 Orientation Tolerance

An orientation tolerance specifies one of the following:

(a) a tolerance zone defined by two parallel planes at the specified basic angle from, parallel to, or perpendicular to one or more datum planes or datum axes, within which the surface, axis, or center plane of the considered feature shall be contained. See [Figures 9-1](#) through [9-7](#).

(b) a cylindrical tolerance zone at the specified basic angle from, parallel to, or perpendicular to one or more datum planes or datum axes, within which the axis of the considered feature shall be contained. See [Figures 9-8](#) through [9-15](#).

(c) a tolerance zone defined by two parallel lines at the specified basic angle from, parallel to, or perpendicular to a datum plane or axis, within which the line element of the surface shall be contained. See [Figures 9-16](#) through [9-18](#).

9.3.3 Application of Each Element's Tolerance Zones

Tolerance zones apply to the full extent of a feature, UOS. When it is a requirement to control only individual line elements of a surface, a qualifying notation, such as "EACH ELEMENT" is added to the drawing. See [Figure 9-16](#). This permits control of individual elements of the surface independently in relation to the datum and does not limit the total surface to an encompassing zone. Each distance between the line element tolerance zone boundaries remains normal to the as-designed theoretically perfect surface. Orientation tolerances only constrain rotational degrees of freedom relative to the referenced datums.

Adding a notation such as "EACH RADIAL ELEMENT" invokes a translational degree of freedom that cannot be controlled by orientation tolerances. When control of radial elements is required, profile shall be used. See [subsection 11.9](#).

9.3.4 Application of Zero Tolerance at MMC

When no variations of orientation are permitted at the MMC size limit of a feature of size, the feature control frame contains a zero for the tolerance, modified by the symbol for MMC. If the feature of size is at its MMC limit of size, it shall be perfect in orientation with respect to the datum. A tolerance can exist only as the feature of size departs from MMC. The allowable orientation tolerance is equal to the amount of the

departure. See [Figures 9-14](#) and [9-15](#). These principles are also applicable to features of size toleranced for orientation at LMC. There may be applications in which the full additional allowable tolerance does not meet the functional requirements. In such cases, the amount of additional tolerance shall be limited by stating “MAX” following the MMC modifier. See [Figure 9-15](#).

9.3.5 Explanation of Orientation Tolerance at MMC

An orientation tolerance applied at MMC may be explained in terms of the surface or the axis of a cylindrical feature or the surfaces or center plane of a width feature. In certain cases of extreme form deviation (within limits of size) of the cylinder or width feature, the tolerance in terms of the feature axis or center plane may not be equivalent to the tolerance in terms of the surface. In such cases, the surface method shall take precedence as in [Figure 10-6](#).

(a) *In Terms of the Surface of a Hole.* While maintaining the specified size limits of a hole, no element of the hole surface shall be inside a theoretical boundary (VC) constrained in rotation to the datum reference frame. See [Figure 10-6](#).

(b) *In Terms of the Axis of a Hole.* When a hole is at MMC (minimum diameter), the feature axis shall fall within a cylindrical tolerance zone whose axis is constrained in rotation to the datum reference frame. The axis of a feature is the axis of the unrelated AME. The diameter of this zone is equal to the orientation tolerance. See [Figure 9-14](#). It is only when the hole is at MMC that the specified tolerance zone applies. When the unrelated AME size of the hole is larger than MMC, the orientation tolerance increases. This increase of orientation tolerance is equal to the difference between the specified MMC limit

of size and the unrelated AME size of the hole. When the unrelated AME size is larger than MMC, the specified orientation tolerance for a hole may be exceeded and still satisfy function and interchangeability requirements.

NOTE: These concepts are equally applicable to all features of size except spheres.

9.4 TANGENT PLANE

When it is desired to control a tangent plane established by the contacting points of a surface, the tangent plane symbol shall be added in the feature control frame after the stated tolerance. See [Figures 9-17](#) and [9-18](#). When a tangent plane symbol is specified with a geometric tolerance, a plane contacting the high points of the feature shall be within the tolerance zone established by the geometric tolerance. Some points of the toleranced feature may lie outside of the tolerance zone. The form of the toleranced feature is not controlled by the geometric tolerance. When irregularities on the surface cause the tangent plane to be unstable (i.e., it rocks) when brought into contact with the corresponding toleranced feature, see ASME Y14.5.1M for definition of mathematical requirements.

NOTE: The tangent plane symbol is illustrated with orientation tolerances; however, it may also have applications using other geometric characteristic symbols such as runout and profile when it is applied to a planar feature.

9.5 ALTERNATIVE PRACTICE

As an alternative practice, the angularity symbol may be used to control parallel and perpendicular relationships. The tolerance zones derived are the same as those described in [para. 9.3.2](#). See [Figure 9-4](#).

Figure 9-1 Specifying Angularity for a Plane Surface

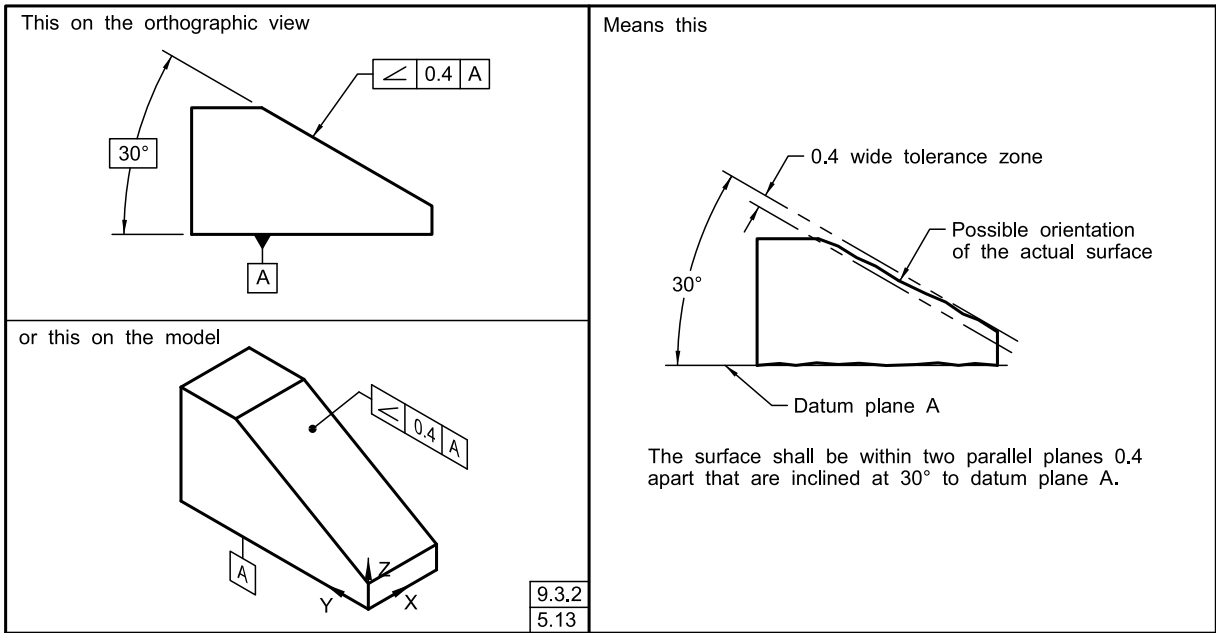

Figure 9-2 Specifying Parallelism for a Plane Surface

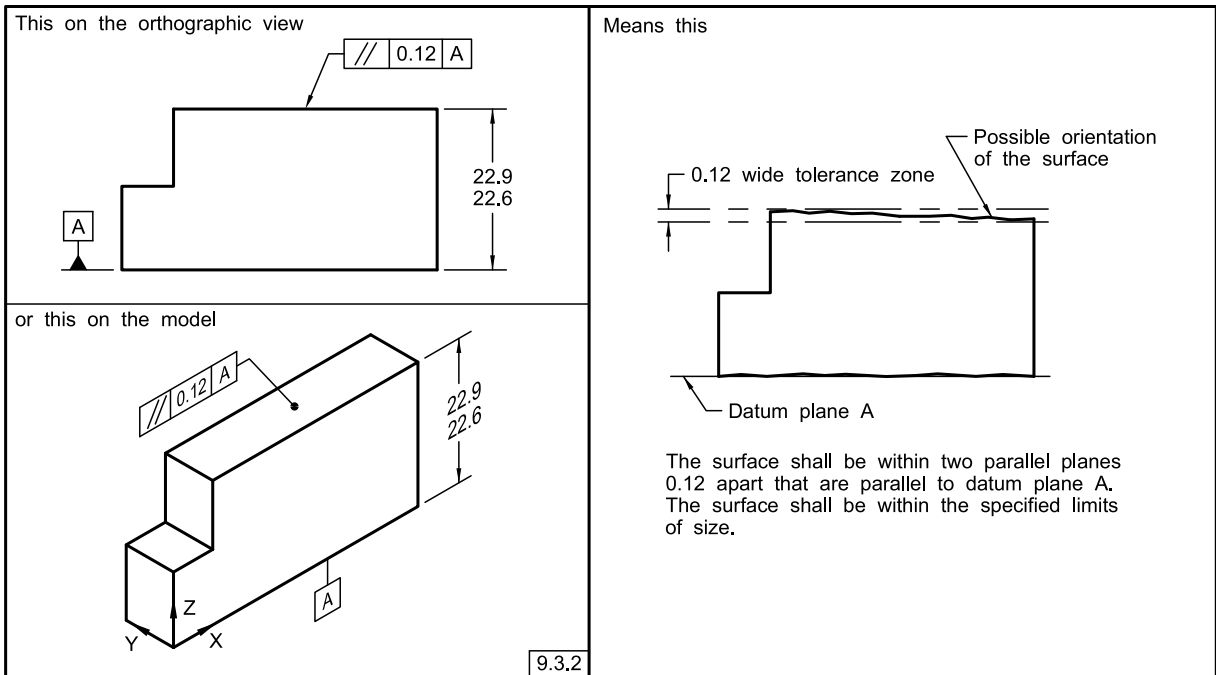

Figure 9-3 Specifying Perpendicularity for a Plane Surface

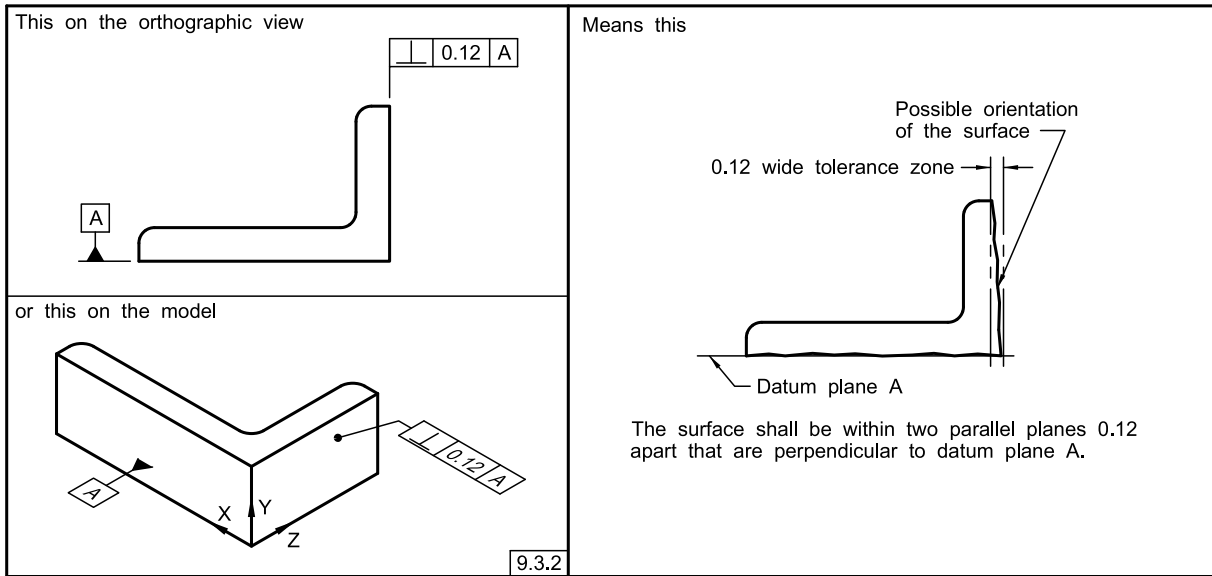

Figure 9-4 Specifying Orientation for a Plane Surface Relative to Two Datums

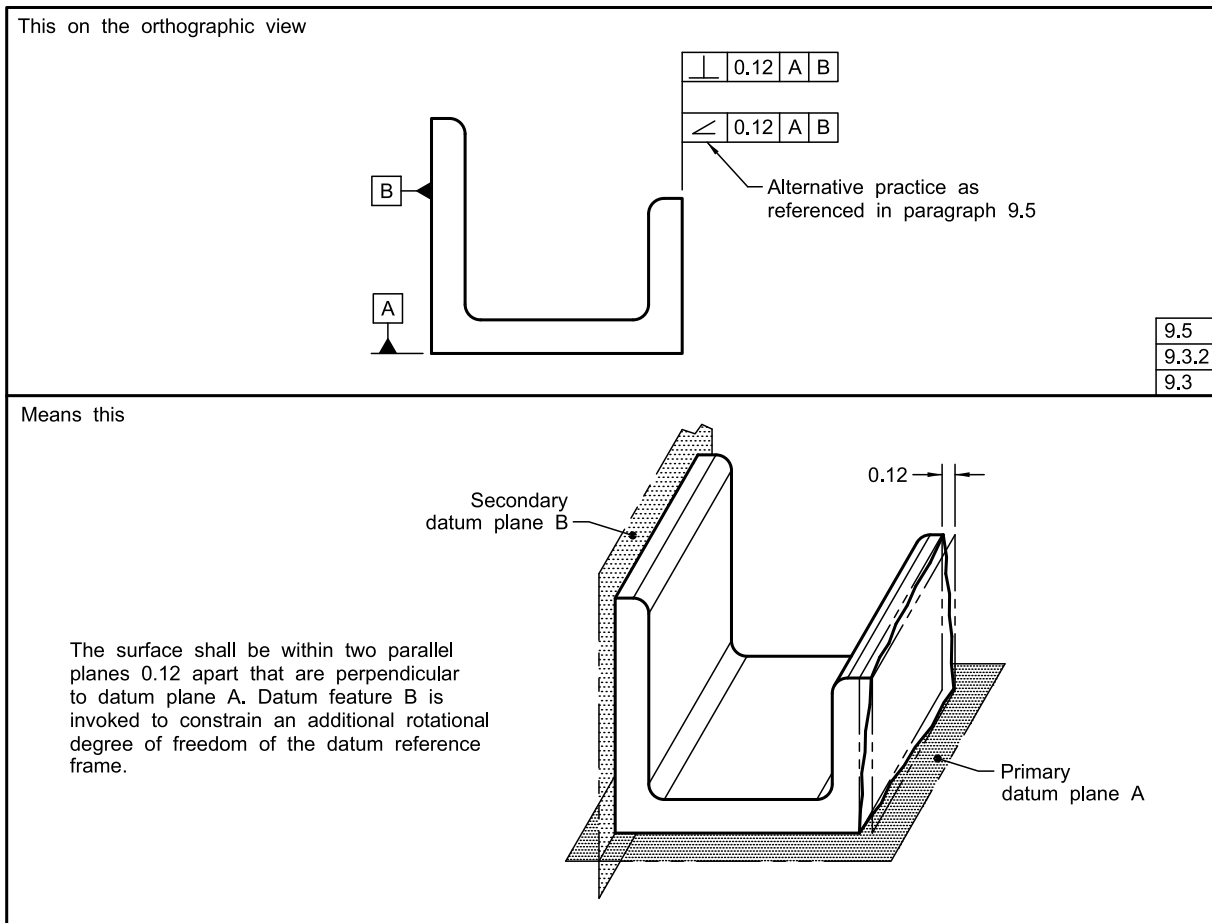

Figure 9-5 Specifying Perpendicularity for a Center Plane (Feature RFS)

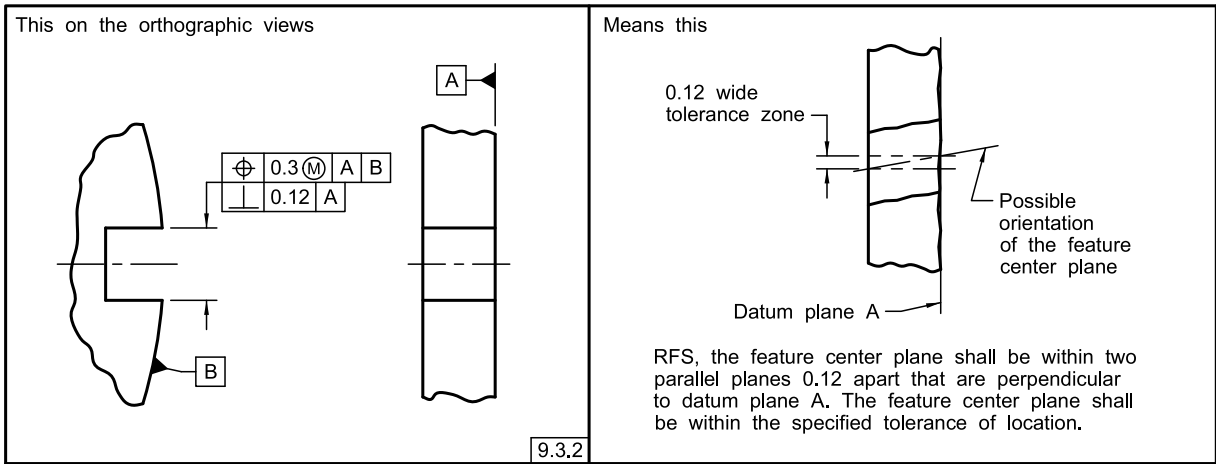

Figure 9-6 Specifying Angularity for an Axis (Feature RFS)

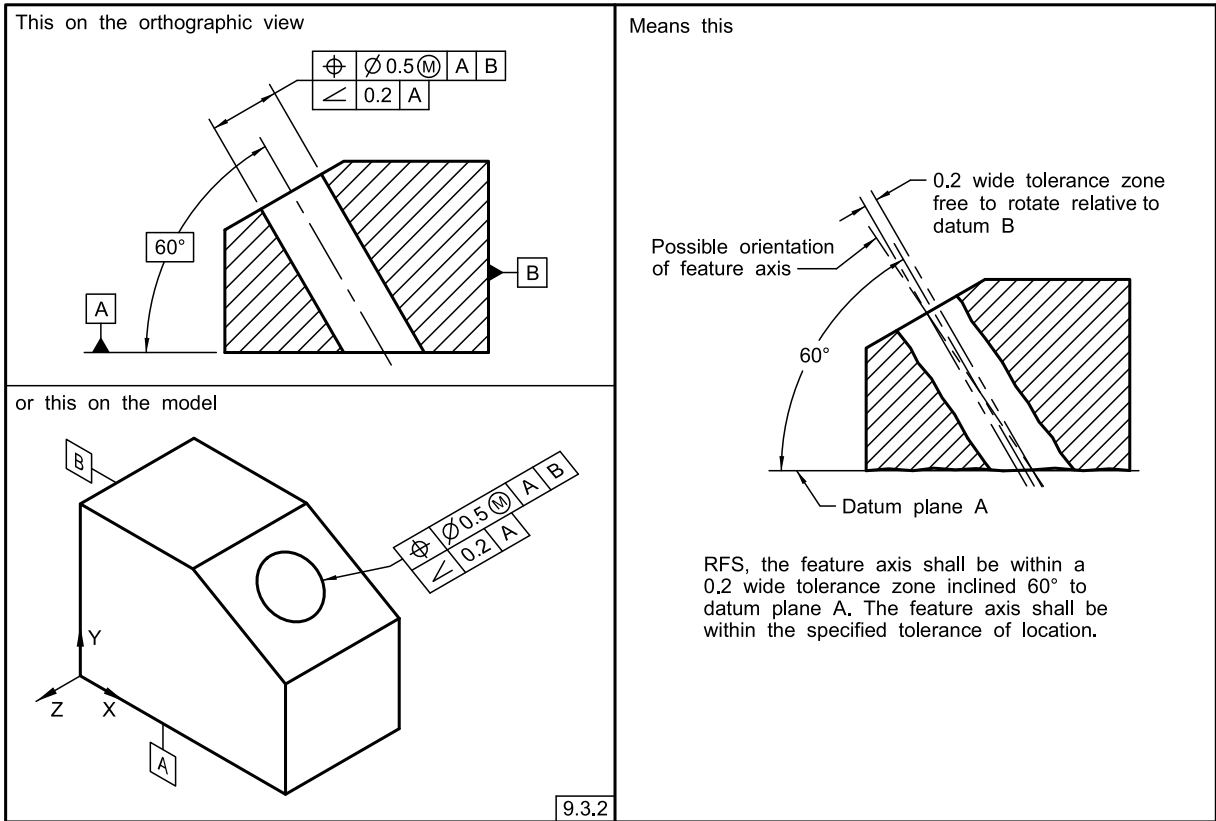

Figure 9-7 Specifying Parallelism for an Axis (Feature RFS)

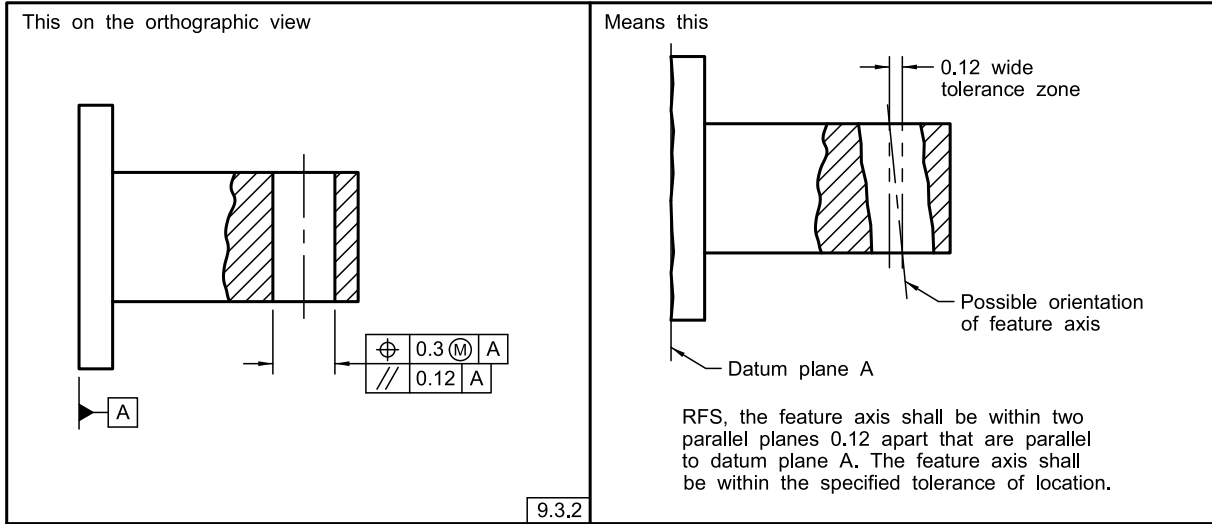
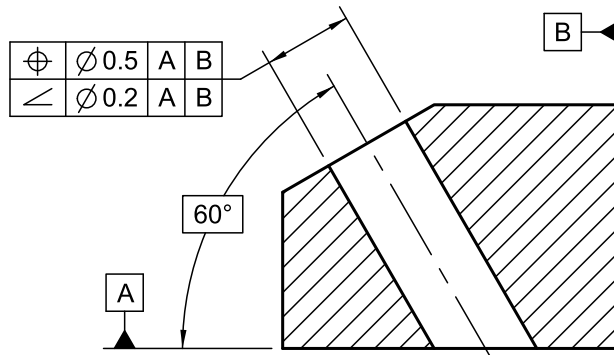

Figure 9-8 Specifying Angularity for an Axis With Two Datum Feature References (Feature RFS)

This on the orthographic view



9.3.2

Means this

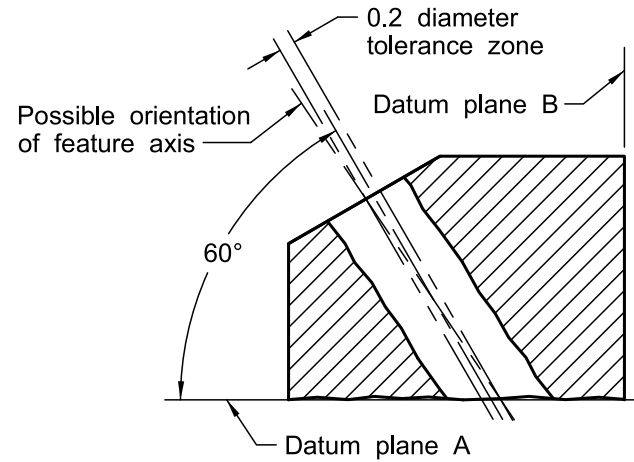

RFS, the feature axis shall be within a 0.2 diameter cylindrical zone inclined 60° to datum plane A. Datum feature B is invoked to constrain an additional rotational degree of freedom of the datum reference frame.

Figure 9-9 Specifying Parallelism for an Axis (Both Feature and Datum Feature RFS)

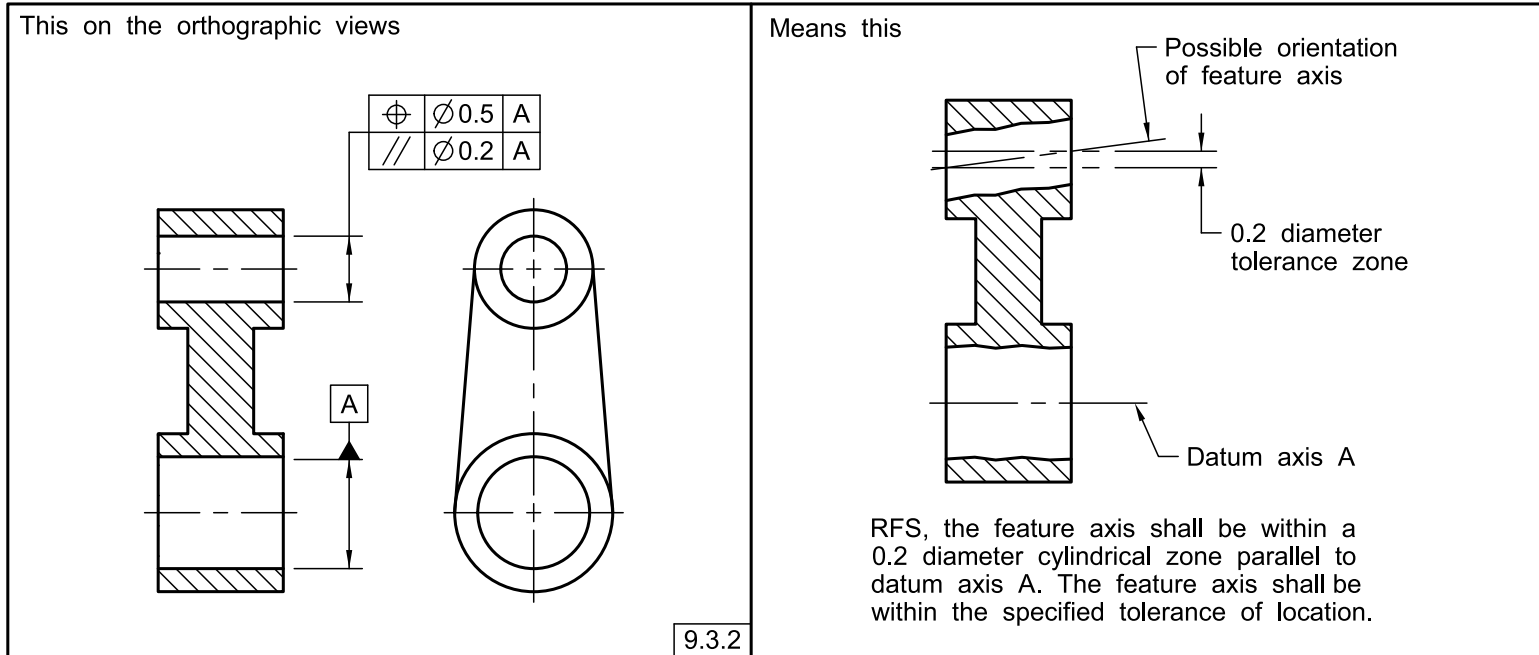
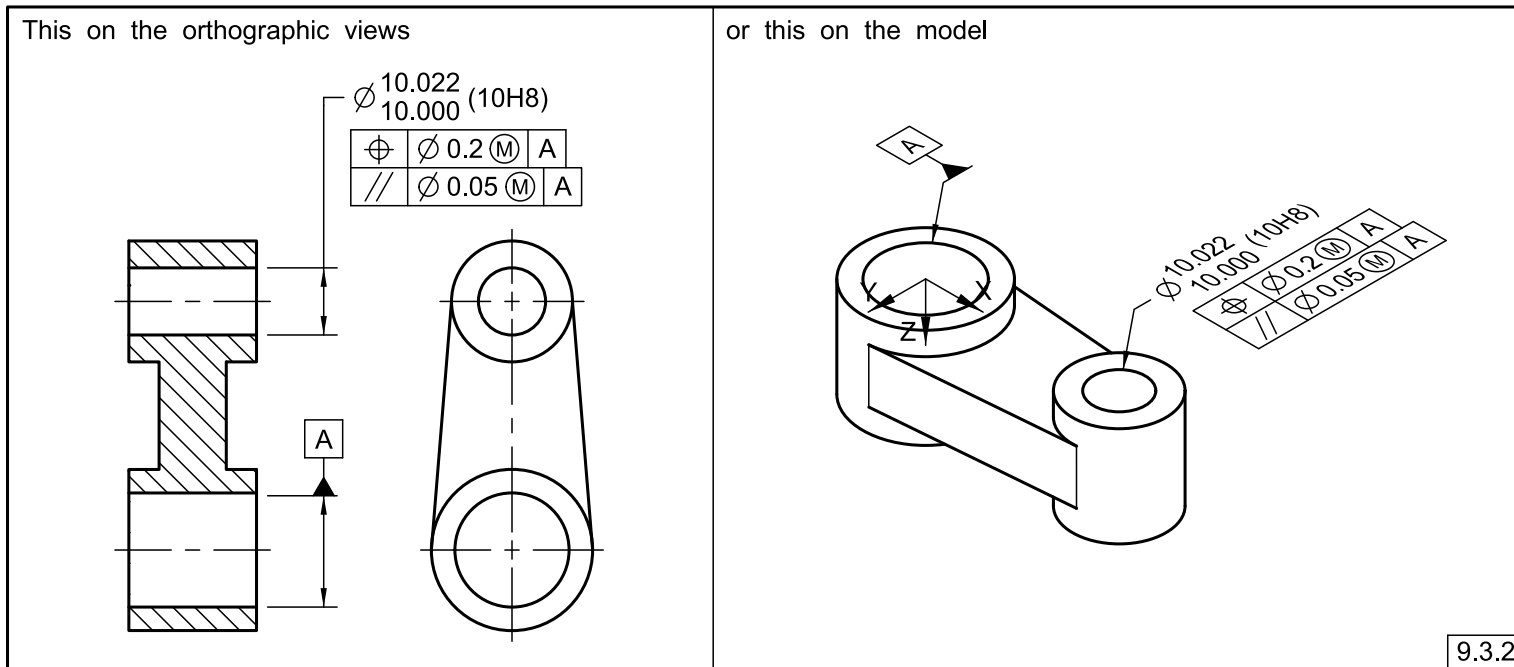
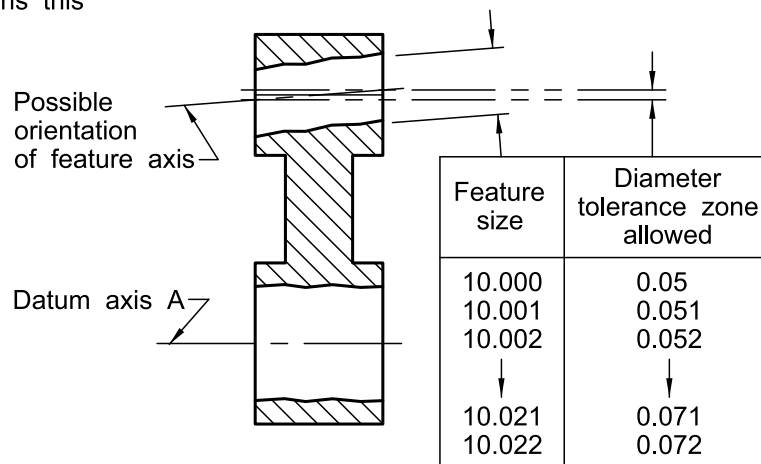

Figure 9-10 Specifying Parallelism for an Axis (Feature at MMC and Datum Feature RFS)



Means this



Where the feature is at MMC (10.00), the allowable parallelism tolerance zone is $\varnothing 0.05$. Where the feature departs from its MMC size, an increase in the parallelism tolerance is allowed that is equal to the amount of such departure. The feature axis shall be within the specified tolerance of location.

Figure 9-11 Specifying Perpendicularity for an Axis at a Projected Height (Threaded Hole or Insert at MMC)

This on the orthographic view

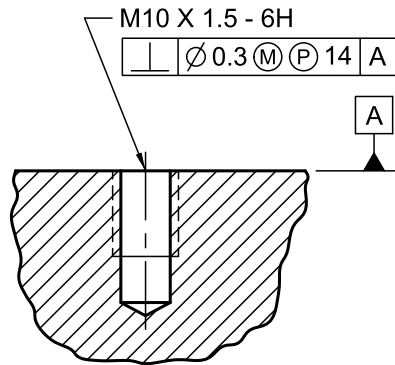

Means this

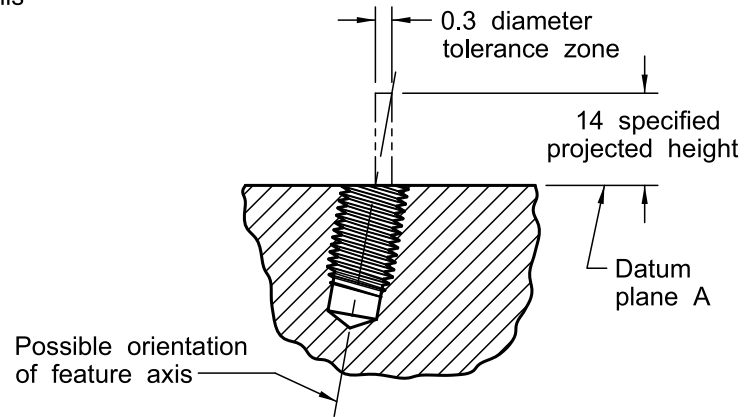

Where the thread profile is at MMC, the feature axis shall be within a cylindrical zone 0.3 diameter that is perpendicular to and projects from datum plane A for the 14 specified height. The projected feature axis shall be within the specified tolerance of orientation over the projected height.

Note: A threaded hole may be located and defined from its thread profile at MMC. Consideration should be given to the additive tolerance that results from the departure from MMC. The centering effect of the fastener at assembly may reduce or negate such added tolerance.

10.4.1
9.3.2

Figure 9-12 Specifying Perpendicularity for an Axis (Pin or Boss RFS)

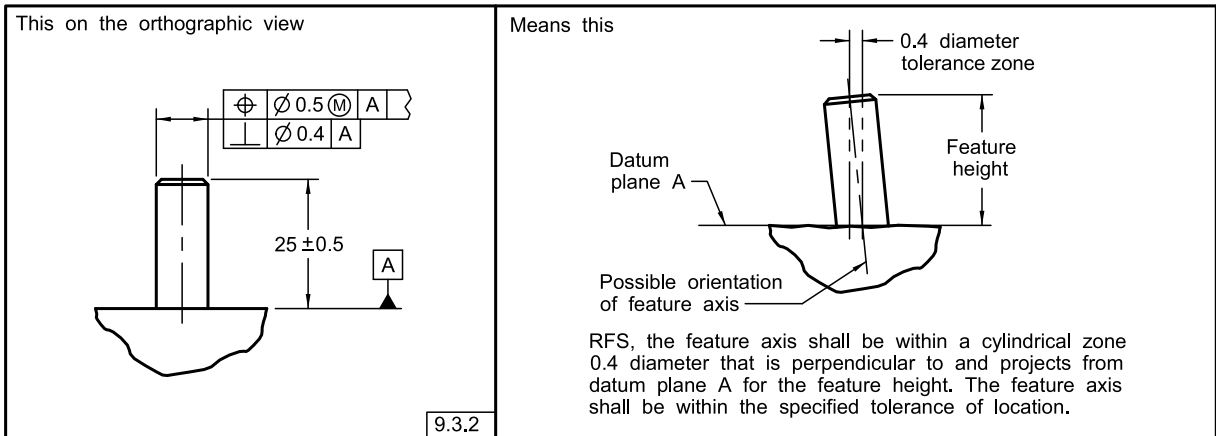

Figure 9-13 Specifying Perpendicularity for an Axis Showing Acceptance Boundary (Pin or Boss at MMC)

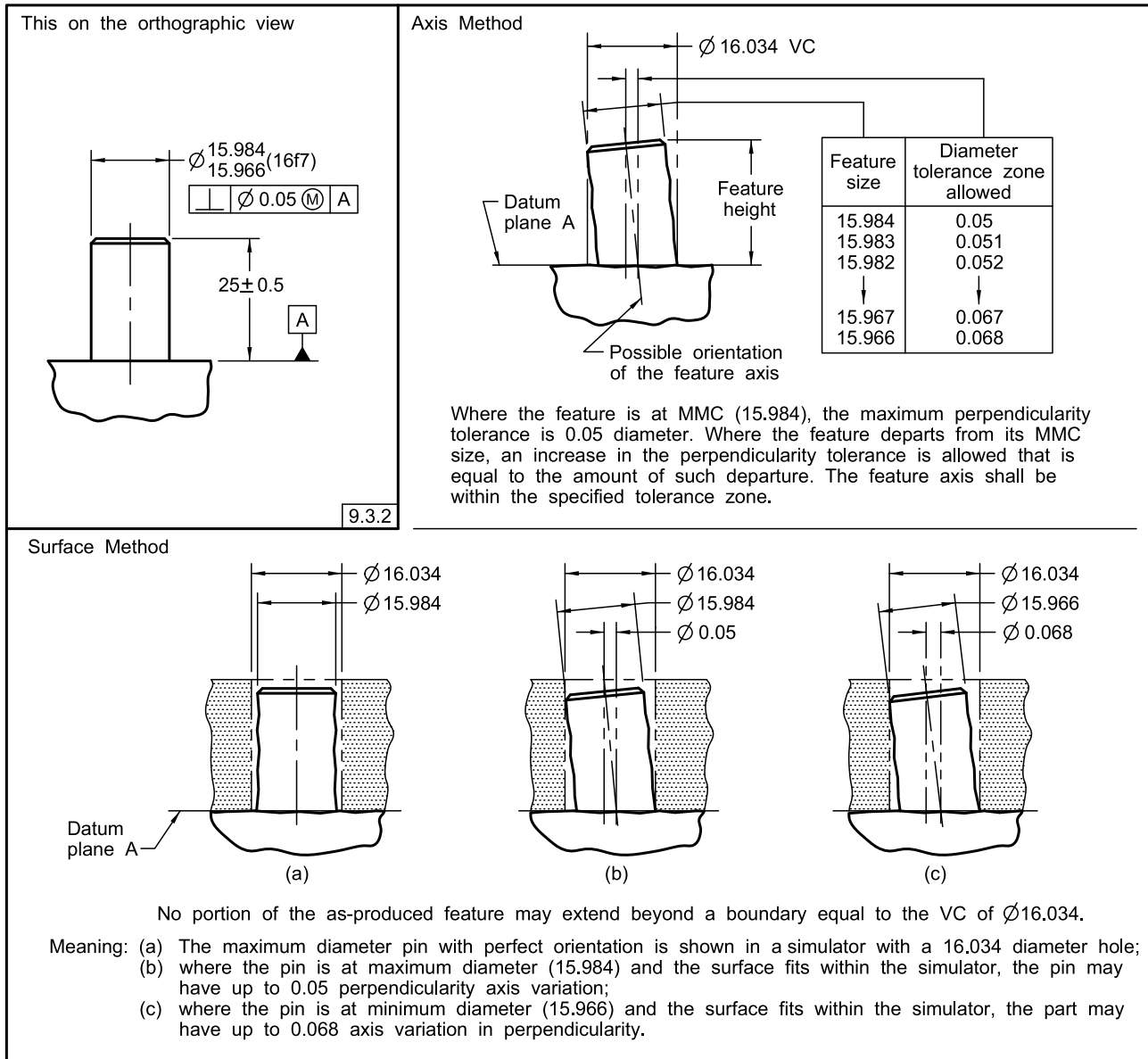

Figure 9-14 Specifying Perpendicularity for an Axis (Zero Tolerance at MMC)

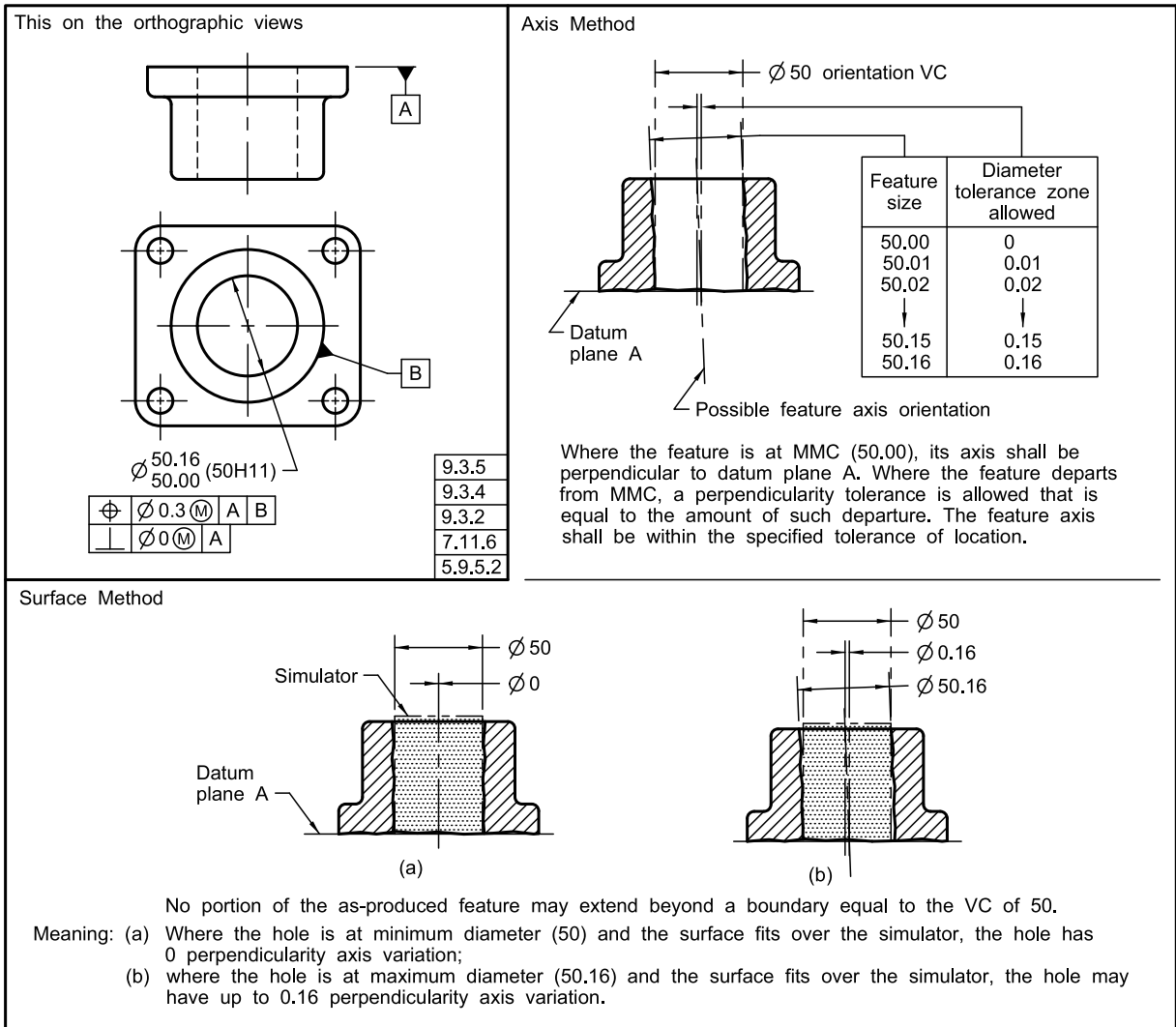
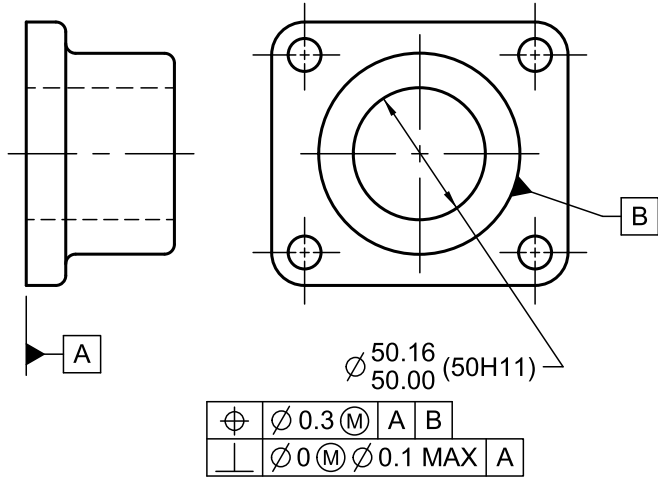
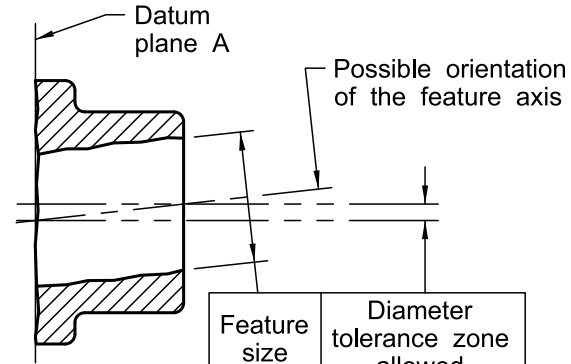

Figure 9-15 Specifying Perpendicularity for an Axis (Zero Tolerance at MMC With a Maximum Specified)

This on the orthographic views



Means this



Feature size	Diameter tolerance zone allowed
50.00	0
50.01	0.01
50.02	0.02
↓	↓
50.10	0.1
↓	↓
50.16	0.1

Where the feature is at MMC (50.00), its axis shall be perpendicular to datum plane A. Where the feature departs from MMC, a perpendicularity tolerance is allowed that is equal to the amount of such departure, up to the 0.1 maximum. The feature axis shall be within the specified tolerance of location.

9.3.4
9.3.2
5.9.5.2

Figure 9-16 Specifying Orientation for a Curved Surface Relative to a Planar Datum Feature

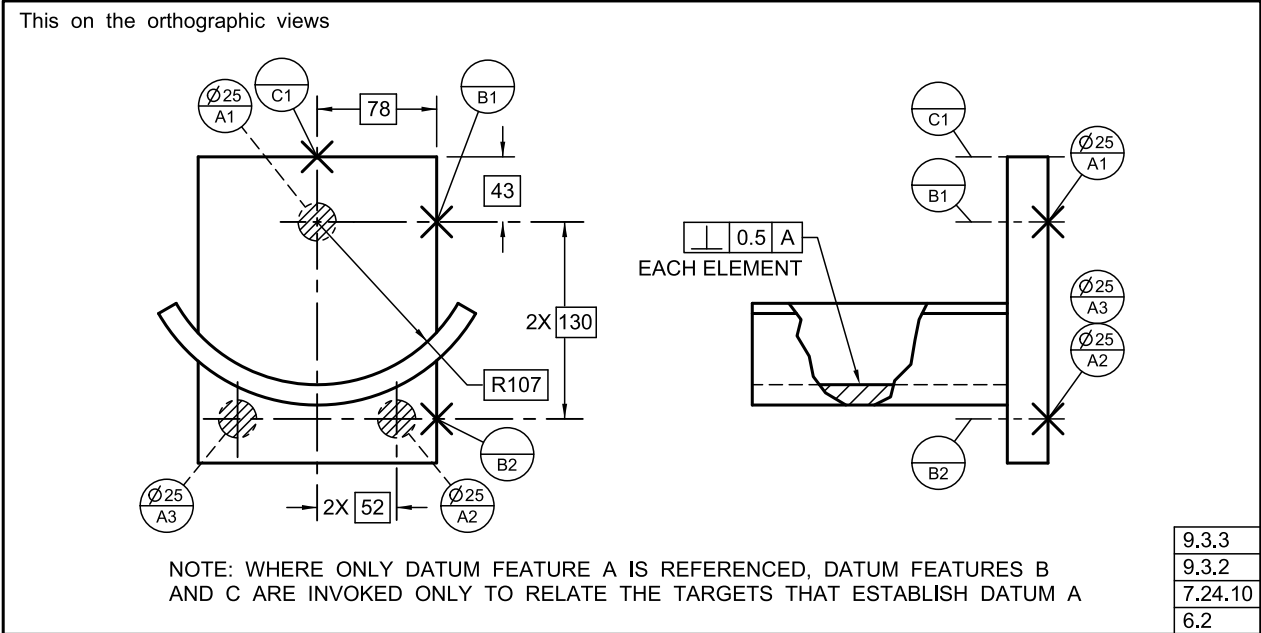

Means this

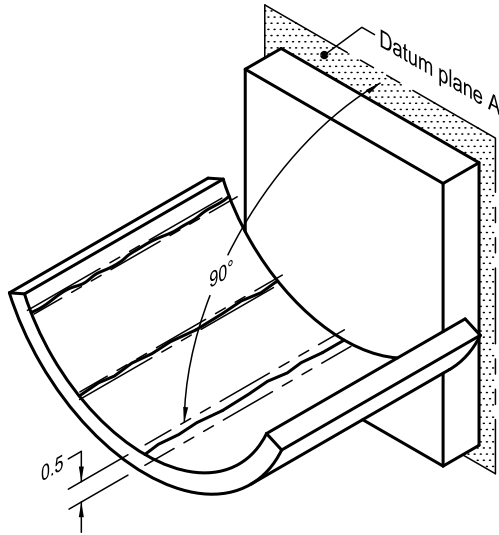

Each element of the surface shall be within the 0.5 tolerance zone that is basically oriented to datum feature A and normal to the nominal surface.

Figure 9-17 Specifying Parallelism With a Tangent Plane and Profile of a Surface

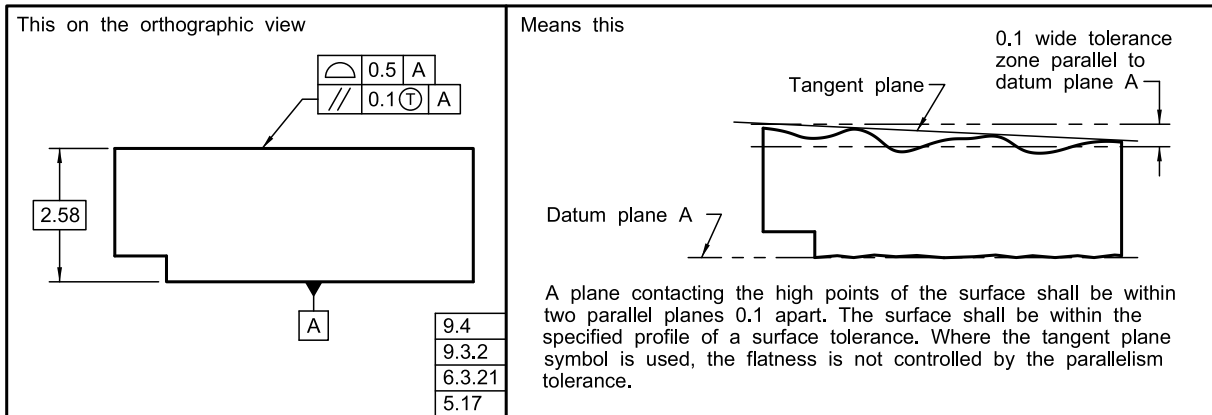
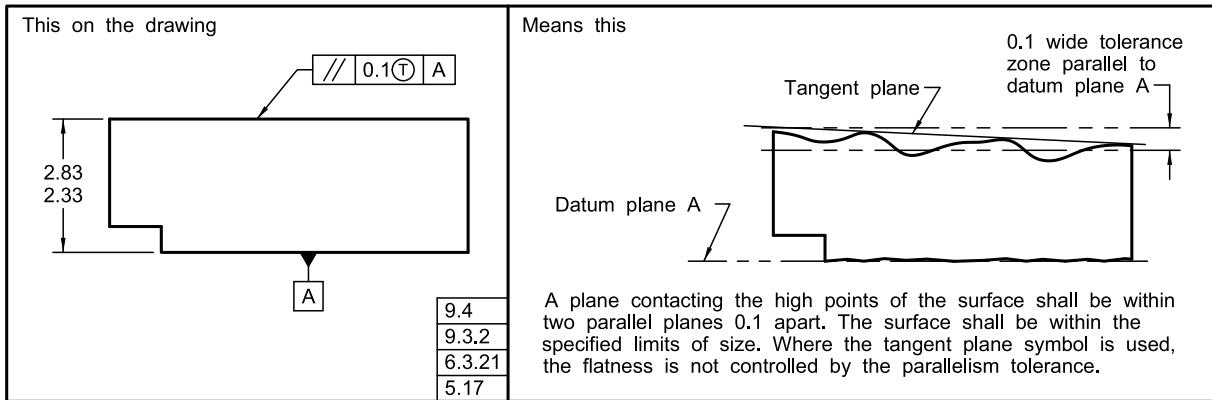

Figure 9-18 Specifying Parallelism With a Tangent Plane



Section 10

Tolerances of Position

10.1 GENERAL

This Section establishes the principles of tolerances of location through application of position tolerances. Position may be used to control the following relationships:

- (a) center distance between features of size such as holes, slots, bosses, and tabs
- (b) location of features of size [such as in (a)] as a group, from datums
- (c) coaxial relationships of features of size
- (d) symmetrical relationships of features of size

10.2 POSITIONAL TOLERANCING

A positional tolerance establishes requirements as explained in (a) and (b) below.

- (a) a zone within which the center point, axis, or center plane of a feature of size is permitted to vary from a true (theoretically exact) position
- (b) (where specified on an MMC or LMC basis) a boundary, defined as the VC, located at the true (theoretically exact) position, that shall not be violated by the surface or surfaces of the considered feature of size

Basic dimensions establish the true position from specified datums and between interrelated features. A positional tolerance shall be indicated by the position symbol, a tolerance value, applicable material condition modifiers, and appropriate datum feature references placed in a feature control frame.

10.2.1 Components of Positional Tolerancing

Paragraphs 10.2.1.1 through 10.2.1.3 describe the components of positional tolerancing.

10.2.1.1 Dimensions for True Position. Dimensions used to locate true position shall be basic and defined in accordance with para. 5.1.1.2. See Figure 10-1. For applicable notes in digital data files, see ASME Y14.41.

10.2.1.2 Use of Feature Control Frame. A feature control frame is added to the notation used to specify the size and number of features. See Figures 10-2 through 10-4, which show different types of feature pattern dimensioning.

10.2.1.3 Identifying Features to Establish Datums. It is necessary to identify features or features of size on a part to establish datums for dimensions locating true positions except where the positioned features establish the primary datum. (The exception is explained in para. 10.6.2.3.) For example, in Figure 10-2, if datum references had been omitted, it would not be clear whether the inside diameter or the outside diameter was the intended datum feature for the dimensions locating true positions. The intended datum features are identified with datum feature symbols, and the applicable datum feature references are included in the feature control frame. For information on specifying datums in an order of precedence, see subsection 7.10.

10.3 POSITIONAL TOLERANCING FUNDAMENTALS — I

This subsection is a general explanation of positional tolerancing.

10.3.1 Material Condition Basis

Positional tolerancing shall be applied on an MMC, RFS, or LMC basis. When MMC or LMC is required, the appropriate modifier follows the specified tolerance. See subsection 5.8.

10.3.2 RFS as Related to Positional Tolerancing

The design or function of a part may require the positional tolerance to be maintained regardless of the feature's unrelated AME size. RFS, where applicable to the positional tolerance associated with a feature of size, requires the axis, center plane, or center point of each feature of size to be located within the specified positional tolerance regardless of the size of the feature. In Figure 10-5, the six holes may vary in size from 25 dia. to 25.6 dia. Each hole axis shall be located within the specified positional tolerance regardless of the size of the hole.

10.3.3 MMC as Related to Positional Tolerancing

When positional tolerancing at MMC is specified, the stated positional tolerance applies at the feature size limit that results in the maximum material in the part. MMC should be specified in positional tolerancing

applications when the functional consideration is to fit with mating features while allowing an increase in tolerance as the feature of size departs from MMC. See [para. 5.8.1](#) regarding perfect form at MMC.

10.3.3.1 Explanation of Positional Tolerance at MMC.

A positional tolerance applied at MMC may be explained in terms of the surface or the axis of the feature of size. In cases of form or orientation deviation of the feature of size, the tolerance requirements in terms of the axis method are not equivalent to the tolerance requirements in terms of the surface method. The surface method shall take precedence. See [Figure 10-6](#) for an example of possible axis interpretation error due to form deviation. The axis method is shown in this Standard for visualization purposes. See ASME Y14.5.1M. In some instances, the additional tolerance may indirectly benefit features other than the one that departed from MMC.

(a) *Surface Method.* While maintaining the specified size limits of the feature, no element of the surface shall violate a theoretical boundary (VC based on the feature MMC and the specified position tolerance) located at true position. See [Figures 10-7](#) and [10-8](#).

(b) *Axis or Center Plane Method.* When a feature of size is at MMC, its axis or center plane shall fall within a tolerance zone located at true position. The size of this zone is equal to the positional tolerance. See [Figure 10-9](#), illustrations (a) and (b). This tolerance zone also defines the limits of variation in the orientation of the axis or center plane of the feature of size in relation to the datum surface. See [Figure 10-9](#), illustration (c). It is only where the feature of size is at MMC that the specified tolerance value applies. Where the unrelated AME size of the feature of size departs from MMC, positional tolerance increases. See [Figure 10-10](#). This increase of positional tolerance is equal to the difference between the specified MMC limit of size and the unrelated AME size.

10.3.3.2 Calculating Positional Tolerance. [Figure 10-11](#) shows a drawing for one of two identical plates to be assembled with four 14 maximum diameter fasteners. The 14.25 minimum diameter clearance holes are selected with a size tolerance as shown. The required positional tolerance is found by appropriate calculation methods for the specific application. See [Nonmandatory Appendix B](#). The following formula does not accommodate factors other than hole and fastener diameter tolerances:

$$\begin{aligned} T &= H - F \\ &= 14.25 - 14 \\ &= 0.25 \text{ diameter} \end{aligned}$$

Note that if the clearance holes were located exactly at true position, in theory the parts would still assemble with clearance holes as small as 14 diameter. However, otherwise usable parts with clearance holes smaller than 14.25 diameter would be rejected for violating the size limit.

10.3.4 Zero Positional Tolerance at MMC

The application of MMC permits the position tolerance zone to increase to a larger value than the value specified, provided the features of size are within the size limits and the feature of size locations make the part acceptable. However, rejection of usable parts can occur when these features of size are actually located on or close to their true positions but are produced to a size smaller than the specified minimum (outside of limits). The principle of zero positional tolerancing at MMC allows the maximum amount of tolerance for the function of assembly. This is accomplished by adjusting the minimum size limit of a hole to the absolute minimum required for insertion of an applicable maximum fastener located precisely at true position, and specifying a zero positional tolerance at MMC. In this case, the positional tolerance allowed is totally dependent on the unrelated AME size of the considered feature, as explained in [para. 5.8.4](#). [Figure 10-12](#) shows a drawing of the same part shown in [Figure 10-11](#) with a zero positional tolerance at MMC specified. Note that the maximum size limit of the clearance holes remains the same, but the minimum was adjusted to correspond with a 14-diameter fastener. The result is an increase of the size tolerance for the clearance holes, with the increase equal to the positional tolerance specified in [Figure 10-11](#). Although the positional tolerance specified in [Figure 10-12](#) is zero at MMC, the positional tolerance allowed increases directly with the actual clearance hole size as shown by the following tabulation:

Clearance Hole Diameter (Feature Actual Mating Size)	Positional Tolerance Diameter Allowed
14	0
14.1	0.1
14.2	0.2
14.25	0.25
14.3	0.3
14.4	0.4
14.5	0.5

10.3.5 LMC as Related to Positional Tolerancing

Where positional tolerancing at LMC is specified, the stated positional tolerance applies at the feature size limit that results in the least material in the part. Specification of LMC requires perfect form at LMC. Perfect form at MMC is not required. Where the feature's minimum material envelope departs from its LMC limit of size, an increase in positional tolerance is allowed, equal to the amount of the departure. See [Figure 10-13](#). LMC shall be specified in positional tolerancing applications when the functional consideration is to ensure that a minimum distance is maintained while allowing an increase in tolerance as the feature of size departs from LMC. See [Figures](#)

10-14 through 10-18. LMC may be used to maintain a desired relationship between the surface of a feature and its true position at tolerance extremes. As with MMC, the surface method shall take precedence over the axis method. See [para. 10.3.3.1](#) and [Figure 10-6](#).

10.3.5.1 LMC to Protect Wall Thickness. [Figure 10-14](#) illustrates a boss and hole combination located by basic dimensions. Wall thickness is minimum when the boss and hole are at their LMC sizes and both features of size are displaced in opposite extremes. As each feature of size departs from LMC, the wall thickness may increase. The departure from LMC permits a corresponding increase in the positional tolerance, thus maintaining the desired minimum wall thickness between these surfaces.

10.3.5.2 LMC Applied to Single Features of Size. LMC may also be applied to single features of size, such as the hole shown in [Figure 10-16](#). In this example, the position of the hole relative to the inside web is critical. When LMC is applied, an increase in the positional tolerance is permitted while protecting the wall thickness.

10.3.5.3 Zero Positional Tolerance at LMC. The application of LMC permits the tolerance to exceed the value specified, provided features of size are within the size limits and the feature of size locations make the part acceptable. However, rejection of usable parts can occur where features of size, such as holes, are actually located on or close to their true positions but are produced larger than the specified maximum size (outside of size limits). The principle of zero positional tolerancing at LMC may be used in applications in which it is desired to protect a minimum distance on a part and allow an increase in tolerance when the toleranced feature departs from LMC. This is accomplished by adjusting the maximum size limit of a hole to the absolute maximum allowed to meet functional requirements (such as wall thickness) while specifying a zero positional tolerance at LMC. When this is done, the positional tolerance allowed is totally dependent on the actual minimum material size of the considered feature of size. [Figure 10-15](#) shows the same drawing as [Figure 10-14](#), except the tolerances have been changed to show zero positional tolerance at LMC. Note that the minimum size limit of the hole remains the same, but the maximum was adjusted to correspond with a 20.25-diameter VC. This results in an increase of the size tolerance for the hole, with the increase equal to the positional tolerance specified in [Figure 10-14](#). Although the positional tolerance specified in [Figure 10-15](#) is zero at LMC, the positional tolerance allowed is directly related to the minimum material hole size as shown by the following tabulation:

Hole Diameter (Feature Minimum Material Size)	Positional Tolerance Diameter Allowed
20.25	0
20	0.25
19.75	0.5
19.5	0.75

10.3.6 Datum Feature Modifiers in Positional Tolerances

References to datum features of size shall be made RMB or at MMB or LMB.

10.3.6.1 Datum Features RMB. The functional requirements of some designs may require that a datum feature be applicable RMB. That is, it may be necessary to require the axis of an actual datum feature (such as datum diameter B in [Figure 10-5](#)) to be the datum axis for the holes in the pattern regardless of the datum feature's size. The RMB application does not permit any translation or rotation between the axis of the datum feature and the tolerance zone framework for the pattern of features, where the datum feature size varies.

10.3.6.2 Displacement Allowed by Datum Features at MMB. For some applications, a feature or group of features (such as a group of mounting holes) may be positioned relative to a datum feature(s) of size at MMB. See [Figure 10-19](#), where displacement is allowed when the datum feature departs from MMB.

10.3.6.2.1 Datum Feature of Size at MMB. When a datum feature is at MMB, its axis or center plane is coincident with the datum axis or datum center plane and it determines the location of the pattern of features as a group. The tolerance zone framework is constrained in translation on the datum axis or center plane. See [Figure 10-19](#), illustration (a).

10.3.6.2.2 Departure of Datum Features From MMB. When a datum feature departs from MMB, relative movement can occur between the datum axis or datum center plane and the axis or center plane of the related AME of datum feature B. See [para. 7.11.11](#) and [Figure 10-19](#), illustration (b).

(a) *Effect on Considered Features.* The amount of the datum feature's departure from MMB does not provide additional positional tolerance for each considered feature in relation to the others within the pattern, but it does allow the pattern of features as a group to move within the amount of departure.

(b) *Inspection Method Variation.* If a functional gage is used to check the part, the relative movement between datum axis B and the axis of the datum feature is automatically accommodated. However, this relative movement shall be taken into account if open setup inspection methods are used.

10.3.6.3 Displacement Allowed by Datum Features at LMB. For some applications, a feature or group of features may be positioned relative to a datum feature at LMB. See [Figure 10-18](#). In such a case, allowable displacement results when the datum feature departs from LMB.

10.4 POSITIONAL TOLERANCING FUNDAMENTALS — II

This subsection expands on the principles of the general explanation of positional tolerancing in [subsection 10.3](#).

10.4.1 Projected Tolerance Zone

The application of the projected tolerance zone shall be used where the variation in orientation of threaded or press-fit holes could cause fasteners, such as screws, studs, or pins, to interfere with mating parts. See [Figure 10-20](#). An interference can occur where a tolerance is specified for the location of a threaded or press-fit hole and the hole is inclined within the positional limits. Unlike the floating fastener application involving clearance holes only, the orientation of a fixed fastener is governed by the produced hole into which it assembles. [Figure 10-21](#) illustrates how the projected tolerance zone concept realistically treats the condition shown in [Figure 10-20](#). Note that it is the variation in orientation of the portion of the fastener passing through the mating part that is significant. The location and orientation of the threaded hole are only important insofar as they affect the extended portion of the engaging fastener. Where design considerations require closer control in the orientation of a threaded hole than is required by the positional tolerance, an orientation tolerance applied as a projected tolerance zone may be specified. See [Figure 9-11](#). To control the feature within the part, an additional tolerance may be specified. Where a composite feature control frame is used, the placement of the projected tolerance zone symbol is defined in [para. 10.5.1.7](#). Where multiple single-segment feature control frames are used, the projected tolerance zone symbol shall be shown in all applicable segments.

10.4.1.1 Clearance Holes in Mating Parts. Specifying a projected tolerance zone ensures that fixed fasteners do not interfere with mating parts having clearance hole sizes determined by the formulas recommended in [Nonmandatory Appendix B](#). Further enlargement of clearance holes to provide for extreme variation in orientation of the fastener may not be necessary.

10.4.1.2 Projected Zone Application for Orthographic Views. [Figures 10-22](#) and [10-23](#) illustrate the application of a positional tolerance using a projected tolerance zone in an orthographic view. The specified value for the projected tolerance zone is a minimum and represents the maximum permissible mating part thickness or the maximum installed length or height of the components, such as screws, studs, or dowel pins. See [para.](#)

10.4.1.3. The direction and height of the projected tolerance zone are indicated as illustrated. The minimum extent and direction of the projected tolerance zone are shown in a drawing view as a dimensioned value with a chain line drawn closely adjacent to an extension of the center line of the hole.

10.4.1.3 Stud and Pin Application. Where studs or press-fit pins are located on an assembly drawing, the specified positional tolerance applies only to the height of the projecting portion of the stud or pin after installation, and the specification of a projected tolerance zone is unnecessary. However, a projected tolerance zone is applicable when threaded or plain holes for studs or pins are located on a detail part drawing. In these cases, the specified projected height shall equal the maximum permissible height of the stud or pin after installation, not the mating part thickness. See [Figure 10-24](#).

10.4.2 Coaxial Features

When positional tolerances are used to locate coaxial features, such as counterbored holes, the following practices apply:

(a) A single feature control frame, placed under the specified feature size requirements, establishes the same positional tolerance for all the coaxial features. See [Figure 10-25](#). Identical diameter tolerance zones for all coaxial features are constrained in translation and rotation at the true position relative to the specified datums.

(b) When different positional tolerances are used to locate two or more coaxial features, multiple feature control frames are used. A feature control frame is applied to each coaxial feature. See [Figure 10-26](#), where different diameter tolerance zones for hole and counterbore are coaxially located at the true position relative to the specified datums.

(c) When positional tolerances are used to locate holes and control individual coaxial relationships relative to different datum features, two feature control frames may be used as in (b). In addition, a note shall be placed under the datum feature symbol for one coaxial feature and another under the feature control frame for the other coaxial feature, indicating the number of places each applies on an individual basis. See [Figure 10-27](#).

10.4.3 Closer Control at One End of a Feature of Size

When design permits, different positional tolerances may be specified for the extremities of long holes; this establishes a conical rather than a cylindrical tolerance zone. See [Figure 10-28](#).

10.4.4 Bidirectional Positional Tolerancing of Features of Size

When it is desired to specify a greater tolerance in one direction than another, bidirectional positional tolerancing may be applied. Bidirectional positional tolerancing results in a noncylindrical tolerance zone for locating round holes; therefore, the diameter symbol shall be omitted from the feature control frame in these applications.

NOTE: A further refinement of orientation within the positional tolerance may be required.

10.4.4.1 Rectangular Coordinate Method. For features located by basic rectangular coordinate dimensions, separate feature control frames are used to indicate the direction and magnitude of each positional tolerance relative to specified datums. See [Figure 10-29](#). The feature control frames are attached to dimension lines applied in perpendicular directions. Each tolerance value represents a distance between two parallel planes equally disposed about the true position.

10.4.4.2 Polar Coordinate Method. Bidirectional positional tolerancing may also be applied to features located by basic polar coordinate dimensions relative to specified datums. When a different tolerance is desired in each direction, one dimension line shall be applied in a radial direction and the other perpendicular to the line-of-centers. The positional tolerance values represent distances between two concentric arc boundaries (for the radial direction), and two planes parallel to the plane between the centers and equally disposed about the true position. See [Figure 10-30](#), where a further requirement of perpendicularity within the positional tolerance zone has been specified. In all cases, the shape and extent of the tolerance zone shall be made clear.

10.4.5 Noncircular Features of Size

The fundamental principles of true position dimensioning and positional tolerancing for circular features of size, such as holes and bosses, apply also to noncircular features of size, such as open-end slots, tabs, and elongated holes. For such features of size, a positional tolerance may be used to locate the center plane established by parallel surfaces of the feature of size. The tolerance value represents a distance between two parallel planes; therefore, the diameter symbol shall be omitted from the feature control frame. See [Figures 10-31](#) and [10-32](#).

10.4.5.1 Noncircular Features of Size at MMC. When a positional tolerance of a noncircular feature of size applies at MMC, the following apply:

(a) *In Terms of the Surfaces of a Feature of Size.* While maintaining the specified size limits of the feature, no surface element of an internal feature of size shall be inside a theoretical boundary located at true position

and no surface element of an external feature of size shall be outside a theoretical boundary located at true position. See [Figure 10-33](#).

(b) *In Terms of the Center Plane of a Feature of Size.* When a feature of size is at MMC, its center plane must fall within a tolerance zone defined by two parallel planes equally disposed about the true position. The width of this zone is equal to the positional tolerance. See [Figure 10-34](#). This tolerance zone also defines the limits of variation in the orientation of the center plane of the feature of size in relation to the referenced datums. It is only where the feature of size is at MMC that the specified tolerance zone applies. When the unrelated AME size of an internal feature of size is larger than MMC, additional positional tolerance results. Likewise, where the unrelated AME size of an external feature of size is smaller than MMC, additional positional tolerance results. This increase of positional tolerance is equal to the difference between the specified MMC limit of size and the unrelated AME size of the feature of size.

(c) *In Terms of the Boundary of a Feature of Size.* A positional tolerance applied to a feature of size establishes a control of the surface relative to a boundary. While maintaining the specified size limits of the feature of size, no element of its surface shall violate a theoretical boundary of identical shape located at true position. For an internal feature, the size of the boundary is equal to the MMC size of the feature minus its positional tolerance. See [Figure 10-35](#). For an external feature, the size of the boundary is equal to the MMC size of the feature plus its positional tolerance. The term “BOUNDARY” may be placed beneath the feature control frames but is not required. In this example, a greater positional tolerance is allowed for length than for width. When the same positional tolerance can be allowed for both, only one feature control frame is necessary, directed to the feature by a leader and separated from the size dimensions.

NOTE: This method may also be applied to other irregular shaped features of size when a profile tolerance is applied to the feature and the center is not conveniently identifiable. See [subsection 11.8](#).

10.4.5.2 LMC Applied to a Radial Pattern of Slots. In [Figure 10-17](#), a radial pattern of slots is located relative to an end face and a center hole. LMC is specified to maintain the desired relationship between the side surfaces of the slots and the true position, where rotational alignment with the mating part may be critical.

10.4.6 Spherical Features

A positional tolerance may be used to control the location of a spherical feature relative to other features of a part. See [Figure 10-36](#). The symbol for spherical diameter precedes the size dimension of the feature and the positional tolerance value, to indicate a spherical tolerance zone. When it is intended for the tolerance zone shape

to be otherwise, dimensions shall be shown, similar to the examples shown in [Figures 10-29](#) and [10-30](#) for a bidirectional tolerance zone of a cylindrical hole.

10.4.7 Nonparallel Axis Hole Patterns

Positional tolerancing may be applied to a pattern of holes where axes are neither parallel to each other nor normal to the surface. See [Figure 10-37](#).

10.4.8 Repetitive Pattern of Features of Size Related to a Repeated Datum Reference Frame

When positional tolerances are used to locate patterns of features of size relative to repetitive datums, the feature control frames and datums are specified as shown in [Figures 10-27](#) and [10-38](#). The same note shall be placed beneath or adjacent to the datum feature symbol and also beneath or adjacent to the feature control frame for the controlled features of size indicating the number of places each applies on an individual basis. To establish association with one line of a multiple-segment feature control frame, placement shall be adjacent to the applicable segment. When the individual requirements are shown on the main view or in a CAD model without a detail view, the indication of the number of occurrences shall be shown. [Figure 10-38](#) shows the application of individual requirements in a detail view. When a detail view includes a notation of the number of occurrences of that detail view, then the “6X” on the “INDIVIDUALLY” notation may be omitted. The “6X INDIVIDUALLY” notation beside the datum feature D symbol indicates that each of the six occurrences of the 79.4-diameter hole acts as a separate datum feature and establishes a separate datum D. The “6X INDIVIDUALLY” notation associated with the second segment of the positional tolerances on the “4X” 3.6-diameter holes indicates that each pattern of four holes has a tolerance zone framework located relative to the specified datums.

10.5 PATTERN LOCATION

A pattern of features of size may have multiple levels of positional control required. The pattern of features of size may require a larger tolerance relative to the datum reference frame while a smaller tolerance is required within the pattern. Multiple levels of tolerance control may be applied using composite positional tolerances or multiple single-segment feature control frames.

10.5.1 Composite Positional Tolerancing

Composite positional tolerancing provides an application of positional tolerancing for the location of feature of size patterns as well as the interrelation (constrained in rotation and translation) of features of size within these

patterns. Requirements are annotated by the use of a composite feature control frame. See [para. 6.4.4](#) and [Figure 6-27](#), illustration (a). The position symbol shall be entered once and shall be applicable to all horizontal segments. Each complete horizontal segment in the feature control frames of [Figures 10-39](#) and [10-40](#) should be verified separately.

(a) *PLTZF*. When composite controls are used, the uppermost segment is the pattern-locating control. The PLTZF is constrained in rotation and translation relative to the specified datums. The PLTZF specifies the larger positional tolerance for the location of the pattern of features of size as a group. Applicable datum features are referenced in a desired order of precedence and serve to relate the PLTZF to the datum reference frame. See [Figure 10-39](#), illustration (a).

(b) *FRTZF*. Each lower segment is a feature-relating control that governs the smaller positional tolerance for each feature of size within the pattern (feature-to-feature relationship). Basic dimensions used to relate the PLTZF to specified datums are not applicable to the location of the FRTZF. See [Figure 10-39](#), illustration (b). The toleranced feature shall be within both the PLTZF and the FRTZF. In some instances, portions of the FRTZF may lie outside of the PLTZF and are not usable.

(1) When datum feature references are not specified in a lower segment of the composite feature control frame, the FRTZF is free to rotate and translate.

(2) When datum feature references are specified in a lower segment, the FRTZF is constrained only in rotation relative to the datum reference frame.

(3) When datum feature references are specified, one or more of the datum feature references specified in the upper segment of the frame are repeated, as applicable, and in the same order of precedence, to constrain rotation of the FRTZF. In some instances, the repeated datum feature references may not constrain any degrees of freedom; however, they are necessary to maintain the identical datum reference frame, such as datum feature B in the lower segment in [Figure 10-43](#).

10.5.1.1 Primary Datum Repeated in Lower Segment(s).

As can be seen from the sectional view of the tolerance zones in [Figure 10-39](#), illustration (c), since datum plane A has been repeated in the lower segment of the composite feature control frame, the axes of both the PLTZF and FRTZF cylinders are perpendicular to datum plane A and therefore are parallel to each other. In certain instances, portions of the smaller zones may fall beyond the peripheries of the larger tolerance zones. However, these portions of the smaller tolerance zones are not usable because the axes of the features must not violate the boundaries of the larger tolerance zones. The axes of the holes shall be within the larger tolerance zones and within the smaller tolerance zones. The axes of the actual holes may vary obliquely (out of

perpendicularity) only within the confines of the respective smaller FRTZF positional tolerance zones.

NOTE: The zones in Figures 10-39 and 10-40 are shown as they exist at the MMC of the features. The large zones would increase in size by the amount the features depart from MMC, as would the smaller zones; the two zones are not cumulative.

10.5.1.2 Primary and Secondary Datums Repeated in Lower Segment(s). Figure 10-40 repeats the hole patterns of Figure 10-39. In Figure 10-40, the lower segment of the composite feature control frame repeats datums A and B. The pattern-locating tolerance requirements established by the first segment are the same as explained in Figure 10-39. Figure 10-40, illustration (a) shows that the tolerance cylinders of the FRTZF may be translated (displaced) from the true position locations (as a group) as governed by the tolerance cylinders of the PLTZF, while they are constrained in rotation to datum planes A and B. Figure 10-40, illustration (a) shows that the actual axes of the holes in the actual feature pattern must reside within the tolerance cylinders of both the FRTZF and the PLTZF.

10.5.1.3 In Terms of Hole Surfaces. Figure 10-39, illustrations (d) through (f) illustrate the positional tolerance requirements of the six-hole pattern shown in Figure 10-39, which is explained in terms of hole surfaces relative to acceptance boundaries. See para. 10.3.3.1(a). The result is the same for the surface explanation as for an axis, except as noted in para. 10.3.3.1.

10.5.1.4 Applied to Patterns of Features of Size Relative to Datum Features. Composite positional tolerancing may be applied to patterns of features of size on circular parts. See Figure 10-41. With datum A repeated in the lower segment of the composite feature control frame, Figure 10-41, illustration (b) shows the tolerance cylinders of the FRTZF translated (as a group) from the basic locations within the bounds imposed by the PLTZF, while constrained in rotation to datum plane A.

10.5.1.5 Applied to a Radial Hole Pattern. Figure 10-42 shows an example of a radial hole pattern where the plane of the PLTZF is located from a datum face by a basic dimension. When datum references are not specified in the lower segment of a composite feature control frame, the FRTZF is free to rotate and translate as governed by the tolerance zones of the PLTZF. The same explanation given in para. 10.5.1 also applies to Figure 10-42. With datum plane A referenced in the lower segment of the composite feature control frame, the tolerance zones of the FRTZF (as a group) are constrained in rotation (parallel to datum plane A) and may be translated as governed by the tolerance zones of the PLTZF. See also Figure 10-42, illustrations (a) through (d).

10.5.1.6 Controlling Radial Location. The control shown in Figures 10-43 and 10-44 may be specified when rotational constraint is important but the design permits a feature-relating tolerance zone to be displaced within the bounds governed by a pattern-locating tolerance zone, while being held parallel and perpendicular to the three mutually perpendicular planes of the datum reference frame. See also Figure 10-43, illustrations (a) and (b).

10.5.1.7 Projected Tolerance Zones for Composite Positional Tolerancing. When the design dictates the use of a projected tolerance zone for composite positional tolerancing, the projected tolerance zone symbol shall be placed in all segments of the composite feature control frame. The feature axes shall simultaneously be within both the pattern-locating and the feature-relating tolerance zones.

10.5.1.8 Composite Positional Tolerances — Multiple Segments. Composite tolerances have two or more segments. Each segment of a composite position feature control frame establishes tolerance zones and constraints to any referenced datums shown in the segment. Datum references in the first segment establish all applicable rotational and translational constraints relative to the referenced datums. Datum references in the second and subsequent segments establish only rotational constraints relative to the referenced datums. See Figure 10-45. For a pattern of features with a composite positional tolerance applied, a PLTZF is created by the first segment and a separate FRTZF is created by each subsequent segment. Each FRTZF is constrained only to the referenced datums within the segment. Absence of datum references in a segment indicates that no rotational or translation constraints are established by that segment. See Figure 10-46. The first segment of the given example creates a PLTZF that is a straight line with two 0.5-diameter tolerance zones (at MMC) constrained in rotation and translation relative to datum A, datum B at MMB, and datum C at MMB. The second segment creates an FRTZF that is a straight line with two 0.12-diameter tolerance zones (at MMC) that are constrained in rotation relative to datum A. The third segment creates an FRTZF that is a straight line with two 0.07-diameter tolerance zones (at MMC) with no constraint to any datum.

10.5.2 Multiple Single-Segment Positional Tolerancing

Multiple single-segment positional tolerances provide multiple positional tolerancing requirements for the location of features of size and establish requirements for pattern location as well as the interrelation (constrained in rotation and translation) of features of size within the patterns. Requirements are annotated by the use of two or more feature control frames. The position symbol is entered in each of the single segments. The datum

feature references in any segment are not permitted to be an exact repeat of all the datum feature references in other segments. Each complete horizontal segment may be verified separately. When multiple single-segment positional controls are used, each segment creates a tolerance zone framework. It is neither a PLTZF nor an FRTZF since those terms are specific to composite tolerances. Applicable datum feature references are specified in the desired order of precedence and serve to relate the tolerance zone framework to the datum reference frame. See [Figures 6-27](#), illustration (b) and [10-47](#) through [10-49](#).

10.5.2.1 Multiple Single-Segment Feature Control Frames. When it is desired to invoke basic dimensions along with the datum references, single-segment feature control frames are used. [Figure 10-47](#) shows two single-segment feature control frames. The lower feature control frame repeats datums A and B. [Figure 10-47](#), illustration (a) shows that the tolerance cylinders of the tolerance zone framework for Segment 2 (as a group) are free to be translated (displaced) to the left or right as governed by the basically located tolerance cylinders of the tolerance zone framework for Segment 1, while remaining perpendicular to datum plane A and basically located to datum plane B. [Figure 10-47](#), illustration (b) shows that the actual axes of the holes in the actual feature pattern must reside within both the tolerance cylinders of the tolerance zone framework for Segment 2 and the tolerance zone framework for Segment 1. [Figure 10-47](#), illustration (c) repeats the relationships for the six-hole pattern of features shown in [Figure 10-47](#).

10.5.2.2 Multiple Single Segments Applied to Patterns of Features of Size on Circular Parts. Multiple single-segment positional tolerancing may be applied to patterns of features of size on circular parts. [Figure 10-48](#) shows two single-segment feature control frames. These are used when it is desired to establish a coaxiality relationship between the tolerance zone framework for Segment 2 and Segment 1. [Figure 10-48](#), illustration (a) shows that the tolerance zone framework for Segment 2 may rotate relative to the tolerance zone framework for Segment 1. The actual hole axes of the actual feature of size pattern must reside within both the tolerance cylinders of the tolerance zone framework for Segment 2 and the tolerance zone framework for Segment 1.

10.5.2.3 Multiple Single Segments Applied to a Radial Hole Pattern. [Figure 10-49](#) shows two single-segment feature control frames. These are used when it is desired to specify a need for a coaxiality relationship between the tolerance zone framework for Segment 2 and the tolerance zone framework for Segment 1. A secondary datum reference is shown in the lower feature control frame. [Figure 10-49](#), illustration (a) shows that the tolerance zones of the tolerance zone

framework for Segment 2 are parallel to datum plane A and coaxial about datum axis B. While remaining parallel and coaxial, the tolerance zone framework for Segment 2 may be displaced rotationally, as governed by the tolerance cylinders of the tolerance zone framework for Segment 1. The axes of the features in the actual feature pattern may be displaced, individually or as a pattern, within the boundaries of the smaller tolerance cylinders. Portions of the smaller tolerance zones located outside the larger tolerance zones are not usable, since the actual feature axes must reside within the boundaries of both zones. See [Figure 10-49](#), illustration (b).

10.5.3 Coaxial Positional Tolerances

[Paragraphs 10.5.3.1](#) through [10.5.3.4](#) explain positional tolerancing as applied to coaxial patterns of features of size.

10.5.3.1 Coaxial Pattern of Features of Size. A composite positional tolerance may be used to control the alignment of two or more coaxial features of size. This method controls the coaxiality of features of size without excessively restricting the pattern-locating tolerance.

10.5.3.2 Two or More Coaxial Features of Size in Pattern-Locating Tolerance. Controls, such as those shown in [Figure 10-50](#), may be specified when it is desired to produce two or more coaxial features of size within a relatively larger pattern-locating tolerance zone. The axis of the PLTZF and its tolerance zones are parallel to datums A and B. Since the lower (feature-relating) segment of the feature control frame does not invoke orientation datums, the axis of the FRTZF and its tolerance zones may be skewed relative to the axis of the PLTZF and its tolerance zones. Depending on the actually produced size of each coaxial feature of size, the axis of each individual feature of size may be inclined within its respective cylindrical tolerance zone.

10.5.3.3 Rotational Constraint of Feature-Relating Tolerances. When it is desired to refine the rotational constraint of the FRTZF and its tolerance zones as governed by the boundary established by the PLTZF and its tolerance zones, datum references specified in the upper segment of the frame are repeated in the lower segment, as applicable, in the same order of precedence as in the upper segment of the feature control frame. See [Figure 10-51](#). Since the lower (feature-relating) segment of the feature control frame invokes datums A and B, the common axis of the FRTZF cylinders must be parallel to the axis of the PLTZF cylinders.

10.5.3.4 Multiple Features of Size Within a Pattern. In orthographic views, where holes are of different specified sizes and the same positional tolerance requirements apply to all holes, a single feature control symbol, supplemented by a notation such as “2X” shall be used. See [Figure](#)

10-52. Holes within a pattern may be labeled with a letter and the pattern referenced below the feature control frames. In a model, the “2X” notation and associativity make clear which holes are toleranced. The same tolerance zone relationships apply as for [Figure 10-50](#).

10.5.4 Simultaneous Requirements

Simultaneous requirements are applicable to positional tolerances as well as profile.

10.5.4.1 Simultaneous Requirement RMB. When multiple patterns of features of size are located relative to common datum features not subject to size tolerances, or to common datum features of size specified RMB, they are considered to be a single pattern. For example, in [Figure 10-53](#), each pattern of features of size is located relative to common datum features not subject to size tolerances. Since all locating dimensions are basic and all measurements are from a common datum reference frame, positional tolerance requirements for the part are considered a single requirement. The actual centers of all holes shall be within their respective tolerance zones when measured from datums A, B, and C.

NOTE: The explanation given in [Figure 10-53](#), illustration (a) still applies when independent verification of pattern locations becomes necessary due to size or complexity of the part.

10.5.4.2 Simultaneous Requirement — at MMB or LMB. When multiple patterns of features are located relative to common datum features in the same order of precedence with the same material boundary modifiers, there is an option whether the patterns are to be considered as a single pattern or as having separate requirements. If no note is added adjacent to the feature control frames, the patterns are to be treated as a single pattern. When it is desired to permit the patterns to be treated as separate patterns, a notation such as “SEP REQT” shall be placed adjacent to each feature control frame. See [Figure 10-54](#). This allows the datum features of size to establish a separate datum reference frame for each pattern of features of size, as a group. These datum reference frames may translate and rotate independently of each other, resulting in an independent relationship between the patterns. This principle does not apply to the lower segments of composite feature control frames except as noted in [subsection 7.19](#).

10.5.5 Multiple Positional Tolerances for a Pattern of Features of Size

If different datum features, different datum feature modifiers, or the same datum features in a different order of precedence are specified, this constitutes a different datum reference frame and design requirements. This is not to be specified using the composite positional tolerancing method. A separately specified tolerance, using a second single-segment feature control frame, is

used, including applicable datum features, as an independent requirement. See [Figure 10-55](#).

10.6 COAXIAL FEATURE CONTROLS

The amount of permissible variation from coaxiality may be expressed by a variety of means, including a positional tolerance, a runout tolerance, or a profile of a surface tolerance.

10.6.1 Selection of Coaxial Feature Controls

Selection of the proper control depends on the functional requirements of the design.

(a) When the axis or surface of features must be controlled and the use of the RFS, MMC, or LMC material condition is applicable, positional tolerancing is recommended. See [para. 10.6.2.1](#).

(b) When the surface of a feature must be controlled relative to the datum axis, runout tolerancing is recommended. See [para. 10.6.3](#) and [subsection 12.2](#).

(c) When it is desired to achieve a combined control of size, form, orientation, and location of a feature within the stated tolerance, profile tolerancing is recommended. See [paras. 10.6.5](#) and [11.4.2](#).

10.6.2 Positional Tolerance Control

When the surfaces of revolution are cylindrical and the control of the axes can be applied on a material condition basis, positional tolerancing should be used.

10.6.2.1 Coaxial Relationships. A coaxial relationship may be controlled by specifying a positional tolerance at MMC. See [Figure 10-56](#). A coaxial relationship may also be controlled by specifying a positional tolerance RFS (as in [Figure 10-57](#)) or at LMC (as in [Figure 10-18](#)). The datum feature may be specified on an MMB, LMB, or RMB basis, depending on the design requirements. In [Figure 10-56](#), the datum feature is specified on an MMB basis. In such cases, any departure of the datum feature from MMB may result in an additional displacement between its axis and the axis of the considered feature. See the conditions shown in [Figure 10-56](#). When two or more features are coaxially related to such a datum, e.g., a shaft with several diameters, the considered features are displaced as a group relative to the datum feature, as explained in [para. 10.5.3.2](#) for a pattern of features.

10.6.2.2 Coaxial Features Controlled Within Limits of Size. When it is necessary to control coaxiality of related features within their limits of size, a zero positional tolerance at MMC may be specified. The datum feature is normally specified on an MMB basis. See [Figure 10-56](#), illustration (b). The tolerance establishes coaxial boundaries of perfect form. Variations in coaxiality between the features are permitted only where the features depart from their MMC sizes toward LMC. See [Figure 10-56](#)

for possible displacements. See also [paras. 5.8.4](#) and [6.3.23](#) for use of the “CF” symbol.

10.6.2.3 Coaxial Features Without Datum References.

A coaxial relationship may be controlled by specifying a positional tolerance without datum references, as shown in [Figure 10-58](#). This method allows specific control of feature-to-feature coaxiality. When features are specified with different sizes, a single feature control frame, supplemented by a notation, such as “2X,” shall be used. A positional tolerance specification with no datum reference creates a relationship between the tolerated features but implies no relationship to any other features. The tolerated features may be identified as a single datum feature, which may then be referenced in the feature control frames of other features, as needed.

10.6.3 Runout Tolerance Control

For information on controlling surfaces of revolution, such as cylinders and cones, relative to an axis of rotation with a runout tolerance, see [subsection 12.2](#).

10.6.4 Controlling Features With Positional Tolerances

In [Figure 10-57](#), illustration (a), the axis of the controlled feature’s unrelated AME has been displaced 0.2 to the left, relative to the axis of datum feature A, and 0.5 material has been removed from the right side of the feature’s surface. In [Figure 10-57](#), illustration (b), the axis of the controlled feature’s unrelated AME has also been displaced 0.2 to the left, relative to the axis of datum feature A, while 0.25 material has been removed from the upper side of the feature’s surface and 0.25 material has been removed from the lower side of the feature’s surface. Since the size of the unrelated AME of the controlled features in [Figure 10-57](#) is 25 diameter, the controlled features remain within acceptable limits of size. For coaxial positional tolerance, the location of the axis of the feature’s unrelated AME is controlled relative to the axis of the datum feature. When checked for a coaxial positional tolerance relationship, the items depicted in [Figure 10-57](#) are acceptable.

10.6.5 Profile of a Surface Tolerance Control

For information on controlling the coaxiality of a surface of revolution relative to a datum axis with profile of a surface tolerance, see [para. 11.4.2](#).

10.7 TOLERANCING FOR SYMMETRICAL RELATIONSHIPS

Symmetrical relationships may be controlled using either positional or profile tolerances. However, these two tolerance controls establish significantly different requirements. Positional tolerancing for symmetrical relationships establishes a requirement where the center plane of the unrelated AME of one or more features is congruent with a datum axis or center plane within specified limits. The tolerance value may be specified applicable at MMC, LMC, or RFS and the datum feature references at MMB, LMB, or RMB. Profile tolerancing is explained in [Section 11](#).

10.7.1 Positional Tolerancing at MMC

A symmetrical relationship may be controlled by specifying a positional tolerance at MMC as in [Figure 10-59](#). The explanations given in [paras. 10.4.5.1\(a\)](#) and [10.4.5.1\(b\)](#) apply to the considered feature. The datum feature may be specified on an MMB, LMB, or RMB basis, depending on the design requirements.

10.7.1.1 Zero Positional Tolerancing at MMC for Symmetrical Relationships. When it is necessary to control the symmetrical relationship of related features within their limits of size, a zero positional tolerance at MMC is specified. The tolerance establishes symmetrical boundaries of perfect form. Variations in position between the features are permitted only when the features depart from their MMC sizes toward LMC. This application is the same as that shown in [Figure 10-56](#), illustration (b) except that it applies the tolerance to a center plane location.

10.7.1.2 Positional Tolerancing RFS. Some designs may require a control of the symmetrical relationship between features to apply regardless of their actual sizes. In such cases, the specified positional tolerance is applied RFS and the datum reference applied RMB. See [Figure 10-60](#).

Figure 10-1 Identifying Basic Dimensions

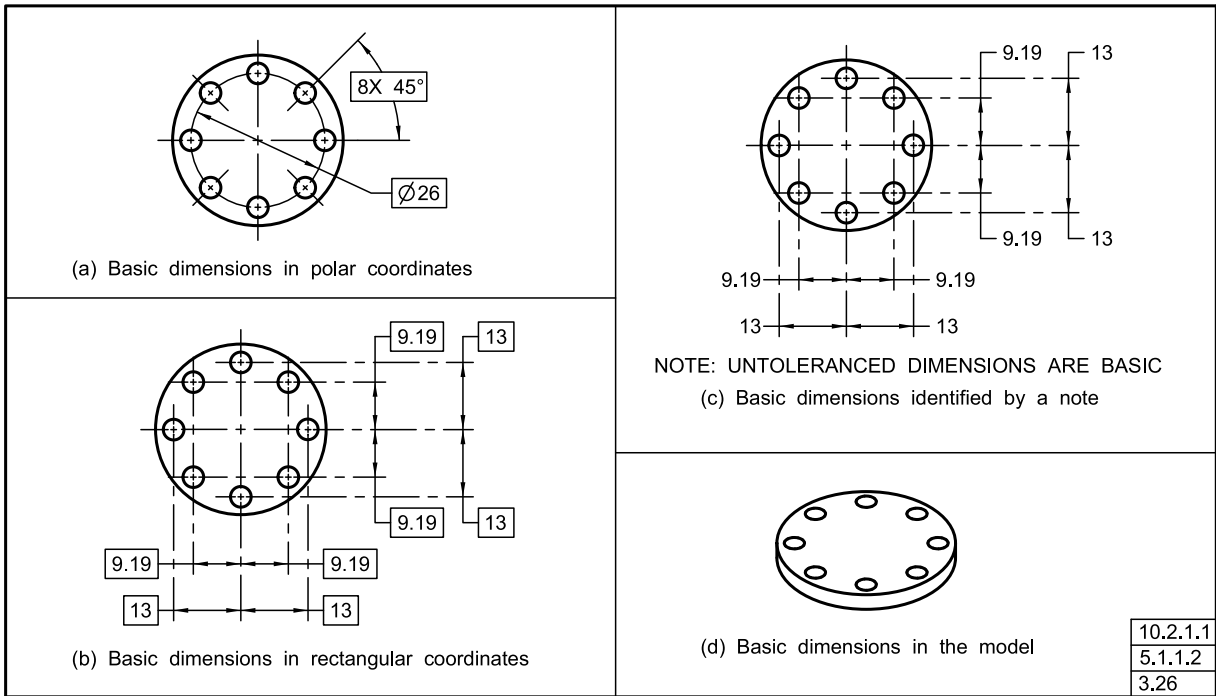

Figure 10-2 Positional Tolerancing With Datum References

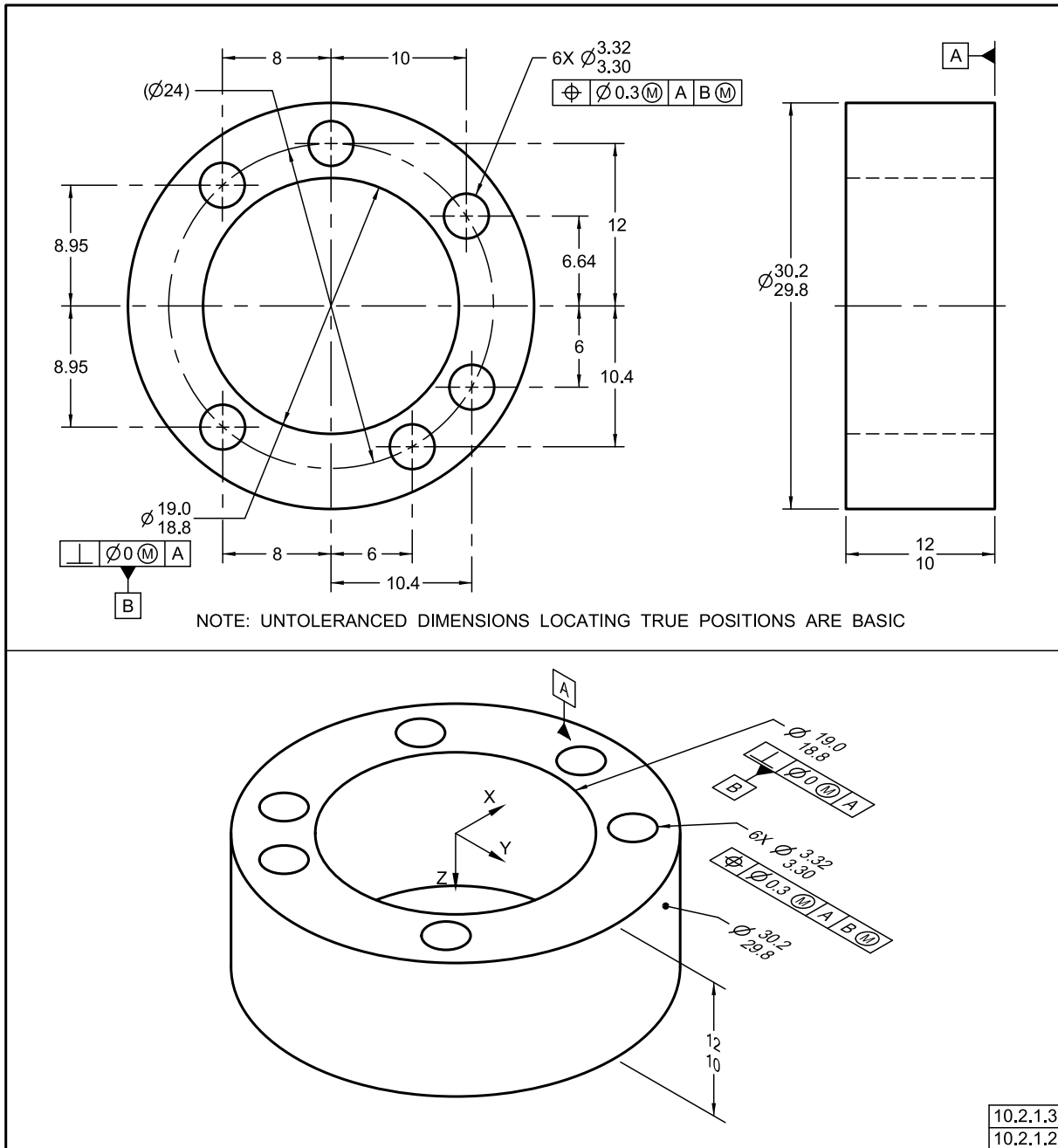

Figure 10-3 Positional Tolerancing Relative to Planar Datum Feature Surfaces

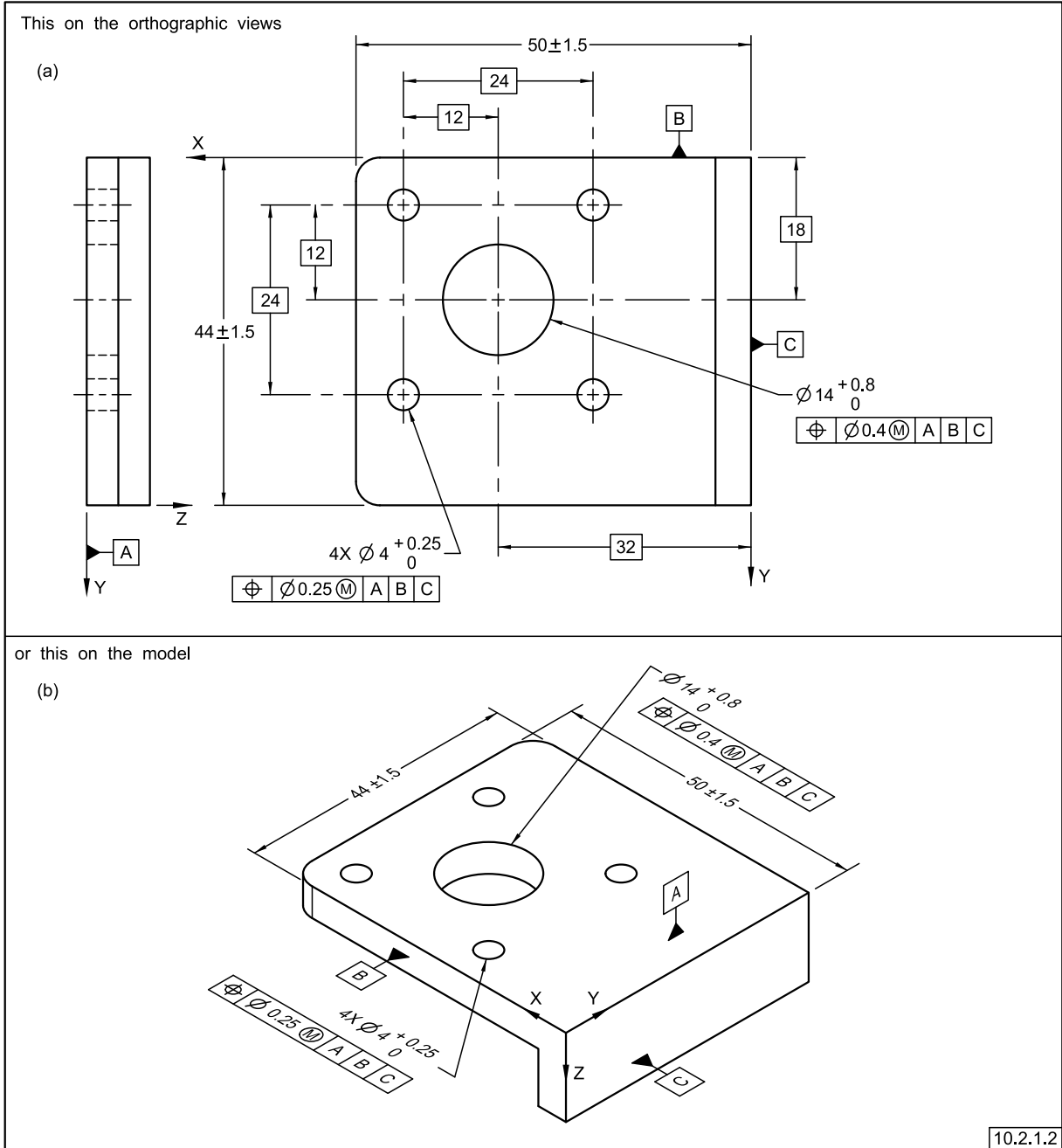

Figure 10-4 Positional Tolerancing at MMC Relative to Datum Feature Center Planes

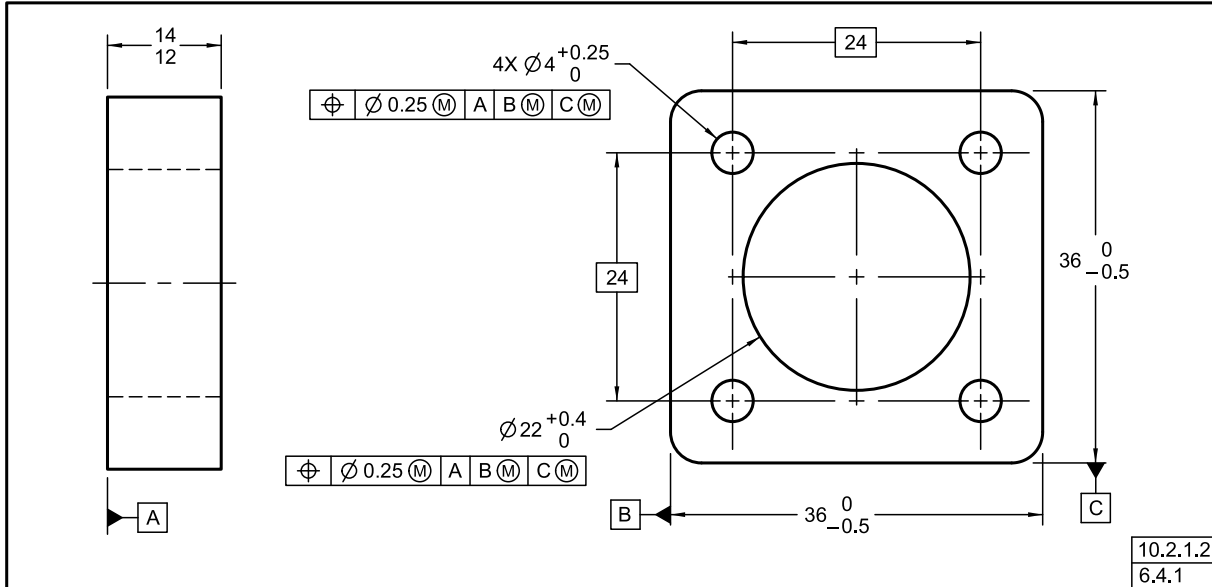

Figure 10-5 RFS Applicable to a Feature Tolerance and RMB Applied to a Datum Feature Reference

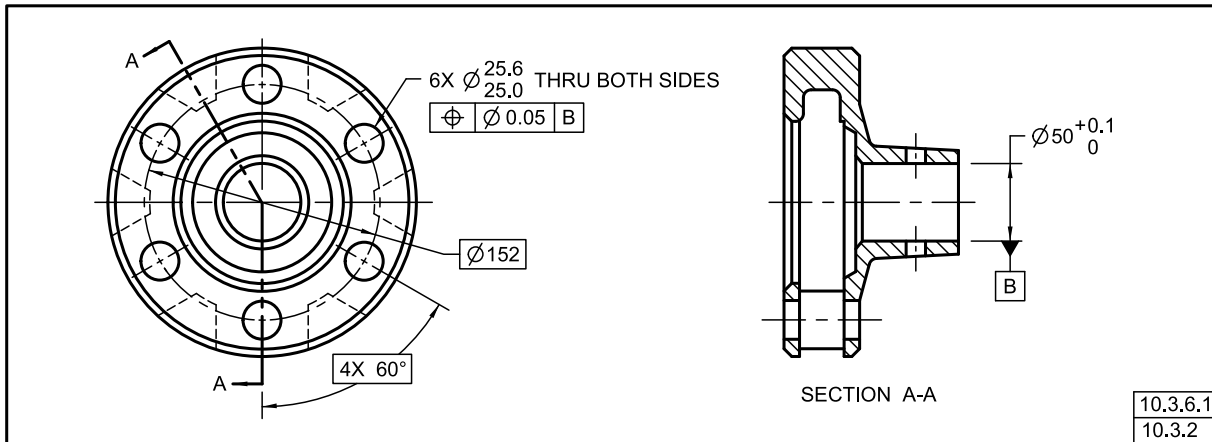

Figure 10-6 Possible Axis Interpretation Error

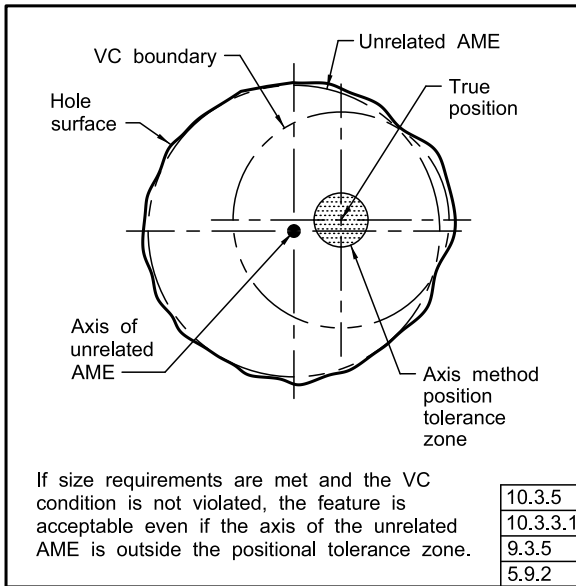

Figure 10-7 Boundary for Surface of a Hole at MMC

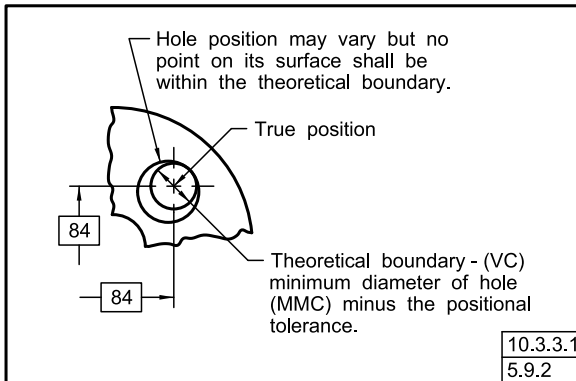

Figure 10-8 Surface Interpretation for Position Tolerance at MMC

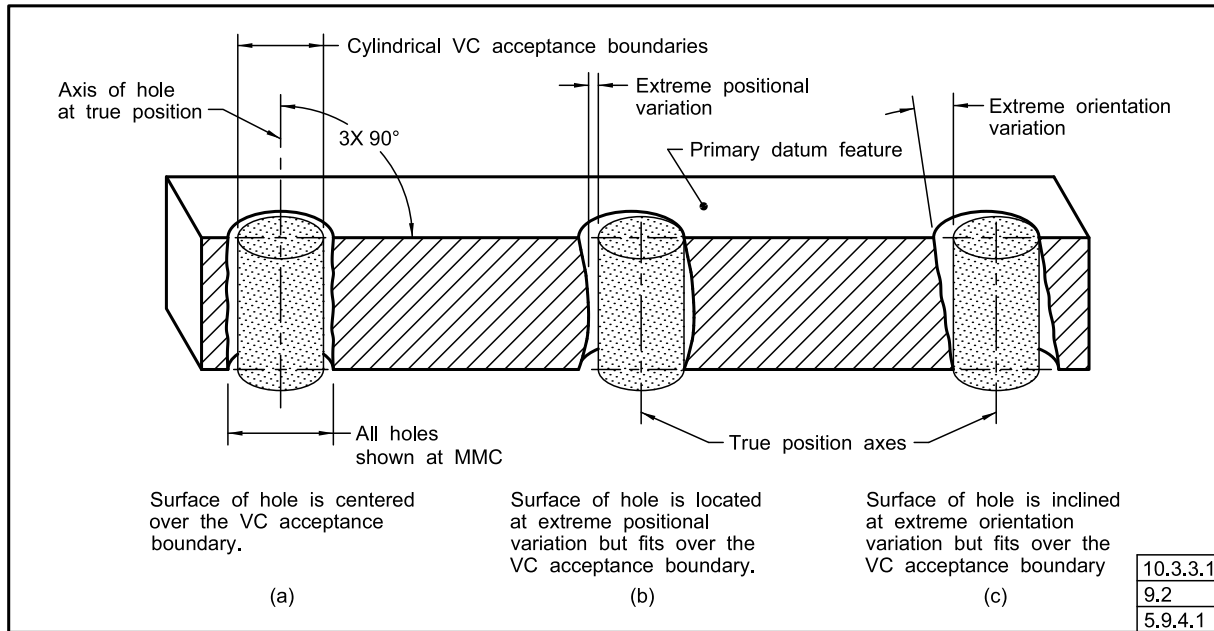

Figure 10-9 Axis Interpretation for Position Tolerance at MMC

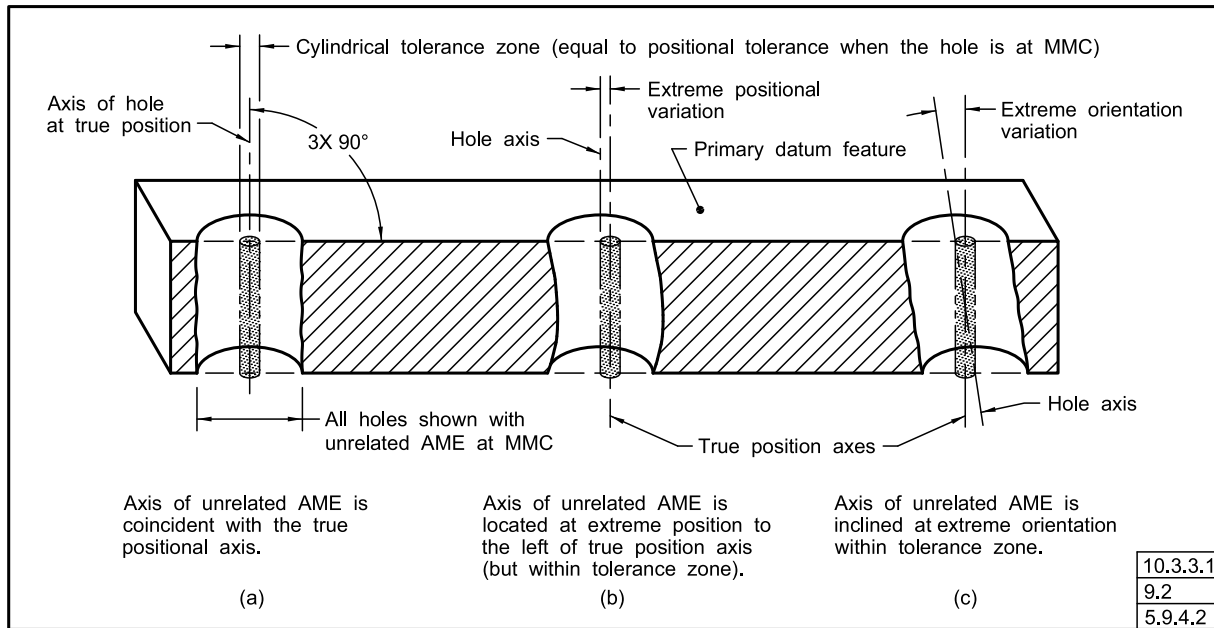

Figure 10-10 Increase in Positional Tolerance Where Hole Is Not at MMC

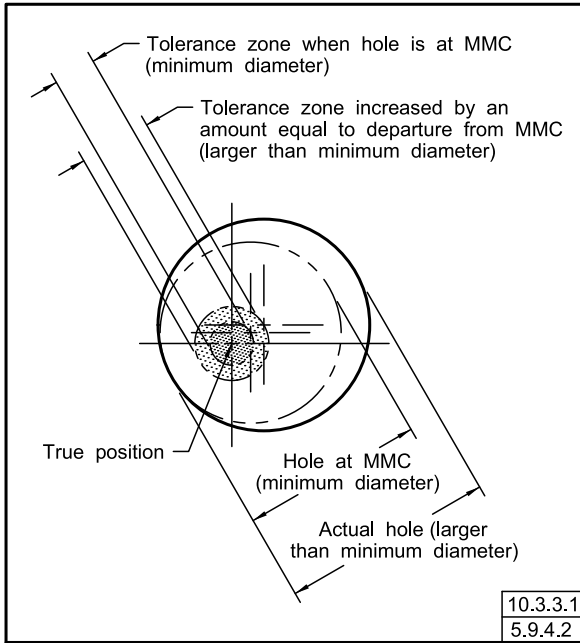

Figure 10-11 Positional Tolerancing at MMC

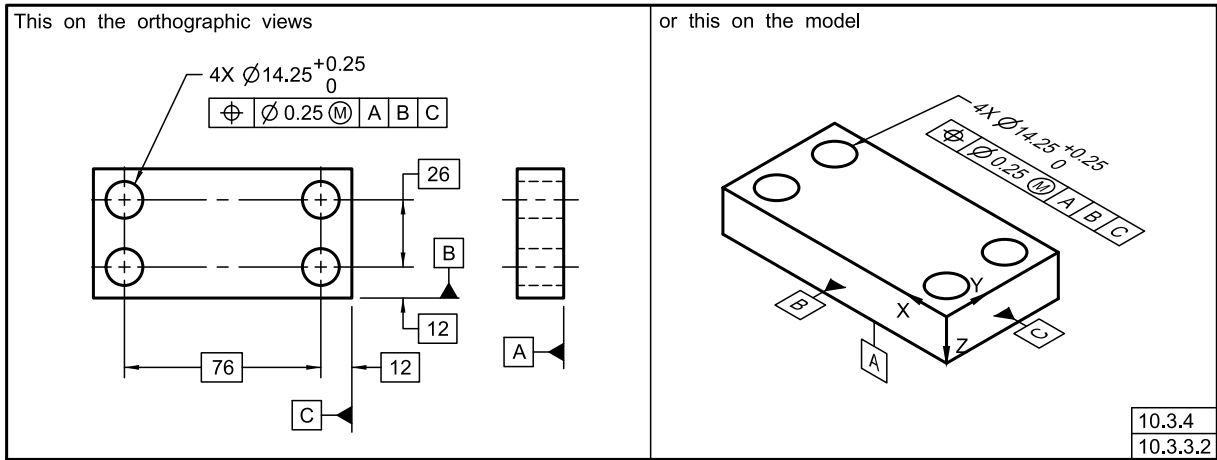
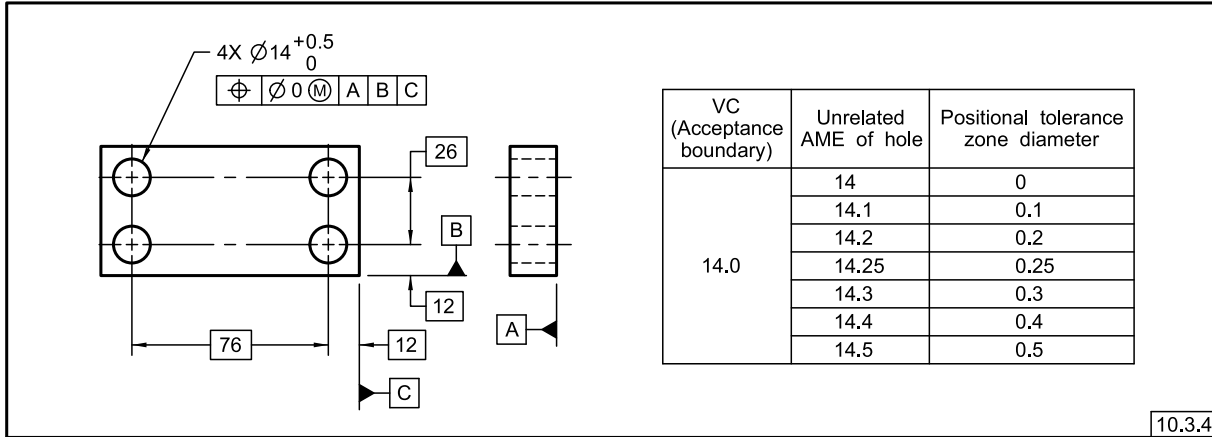
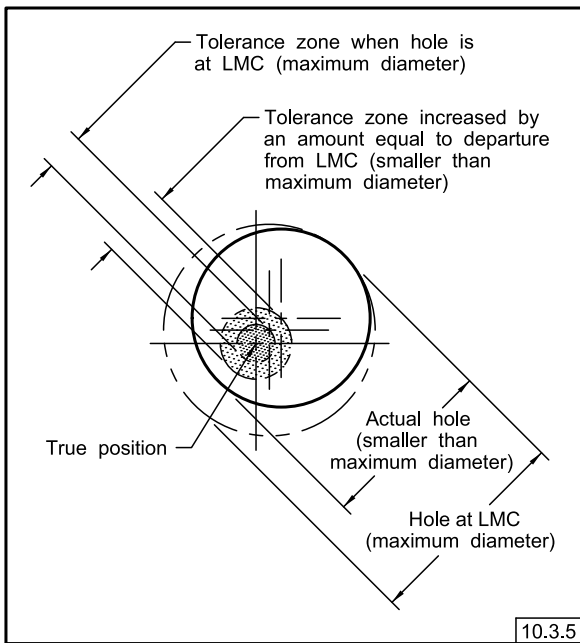

Figure 10-12 Zero Positional Tolerancing at MMC



10.3.4

Figure 10-13 Increase in Positional Tolerance Where Hole Is Not at LMC



10.3.5

Figure 10-14 LMC Applied to Boss and Hole

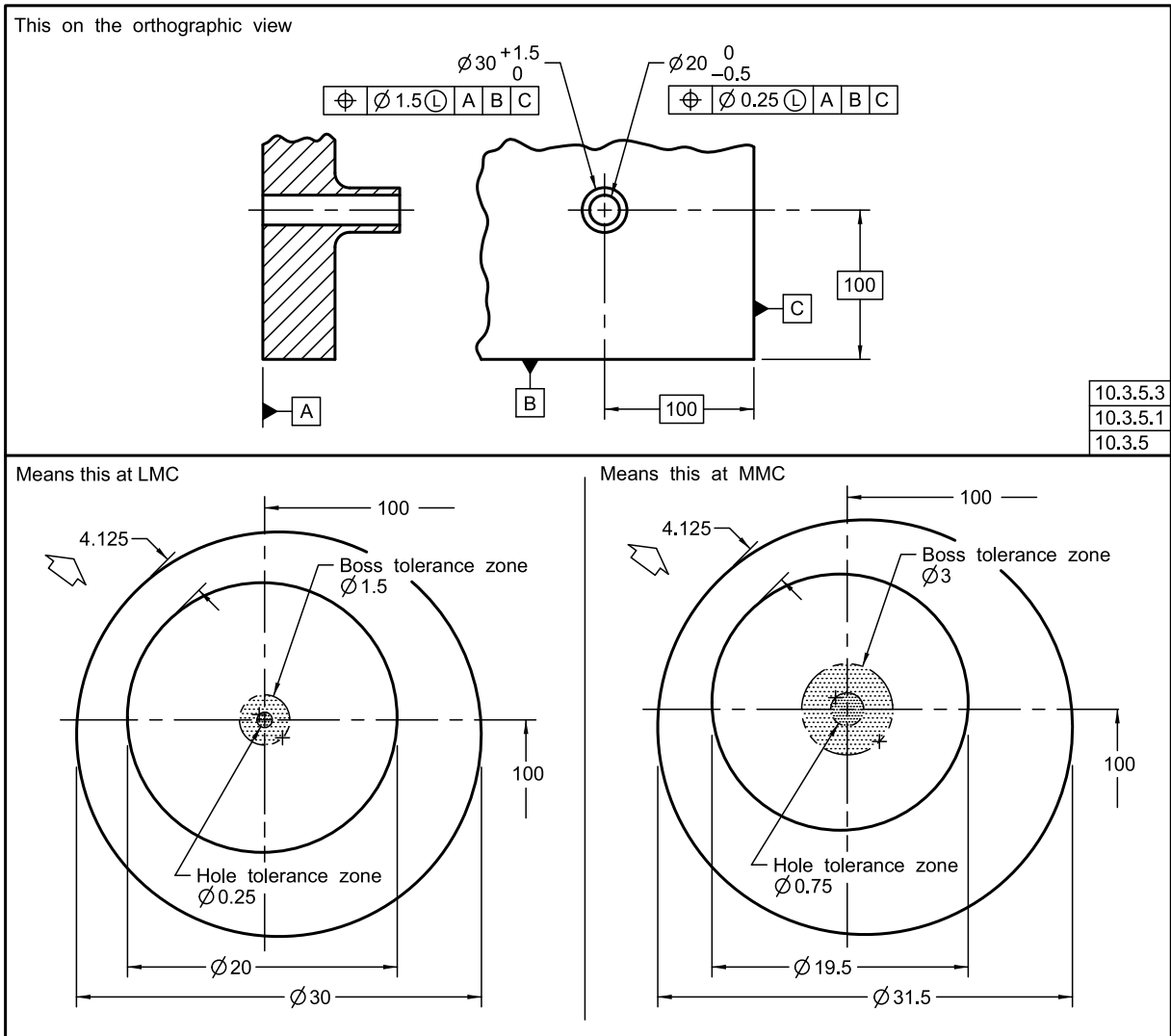

Figure 10-15 Zero Tolerance at LMC Applied to Boss and Hole

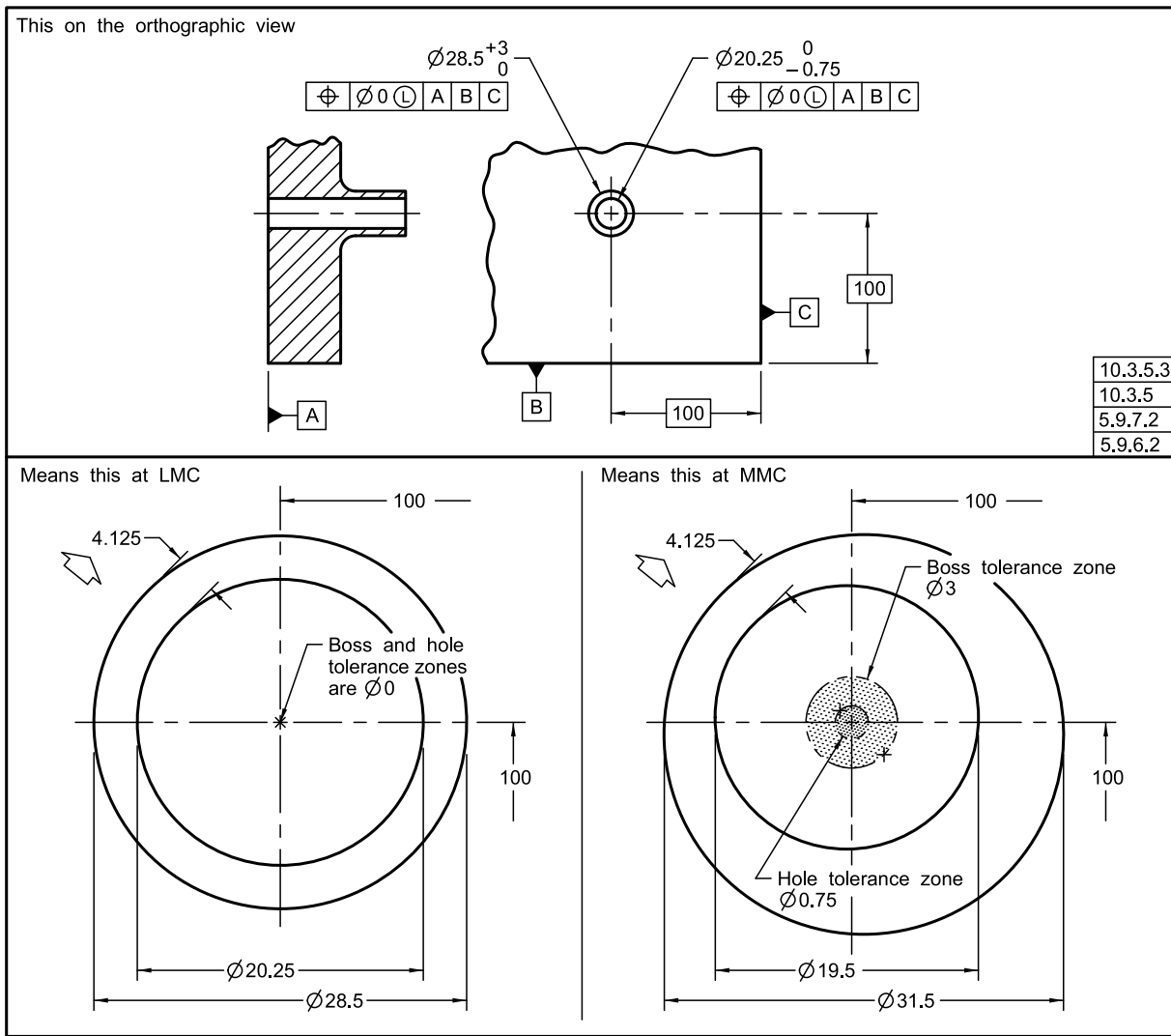

Figure 10-16 LMC Applied to a Single Feature

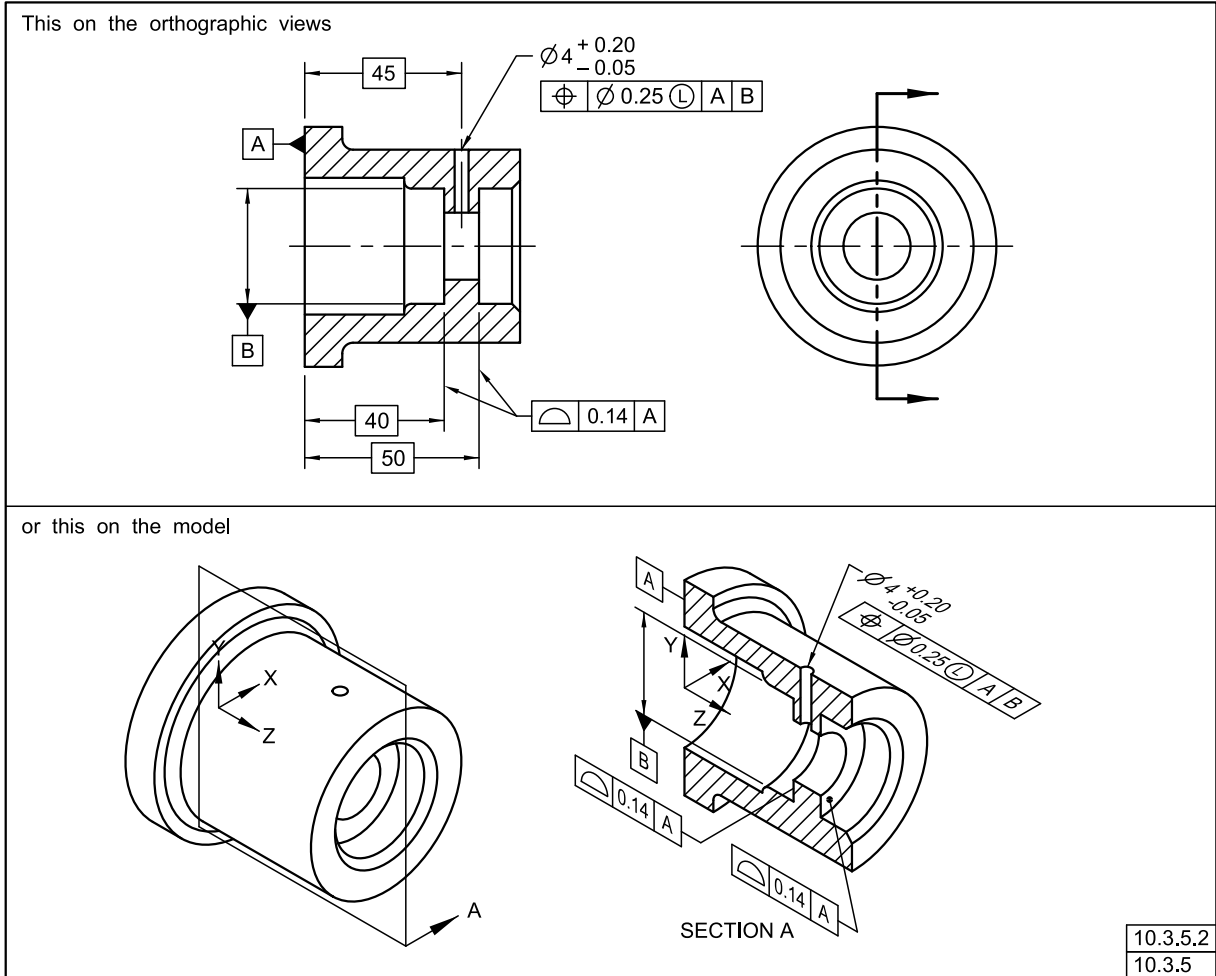

Figure 10-17 LMC Applied to Pattern of Slots

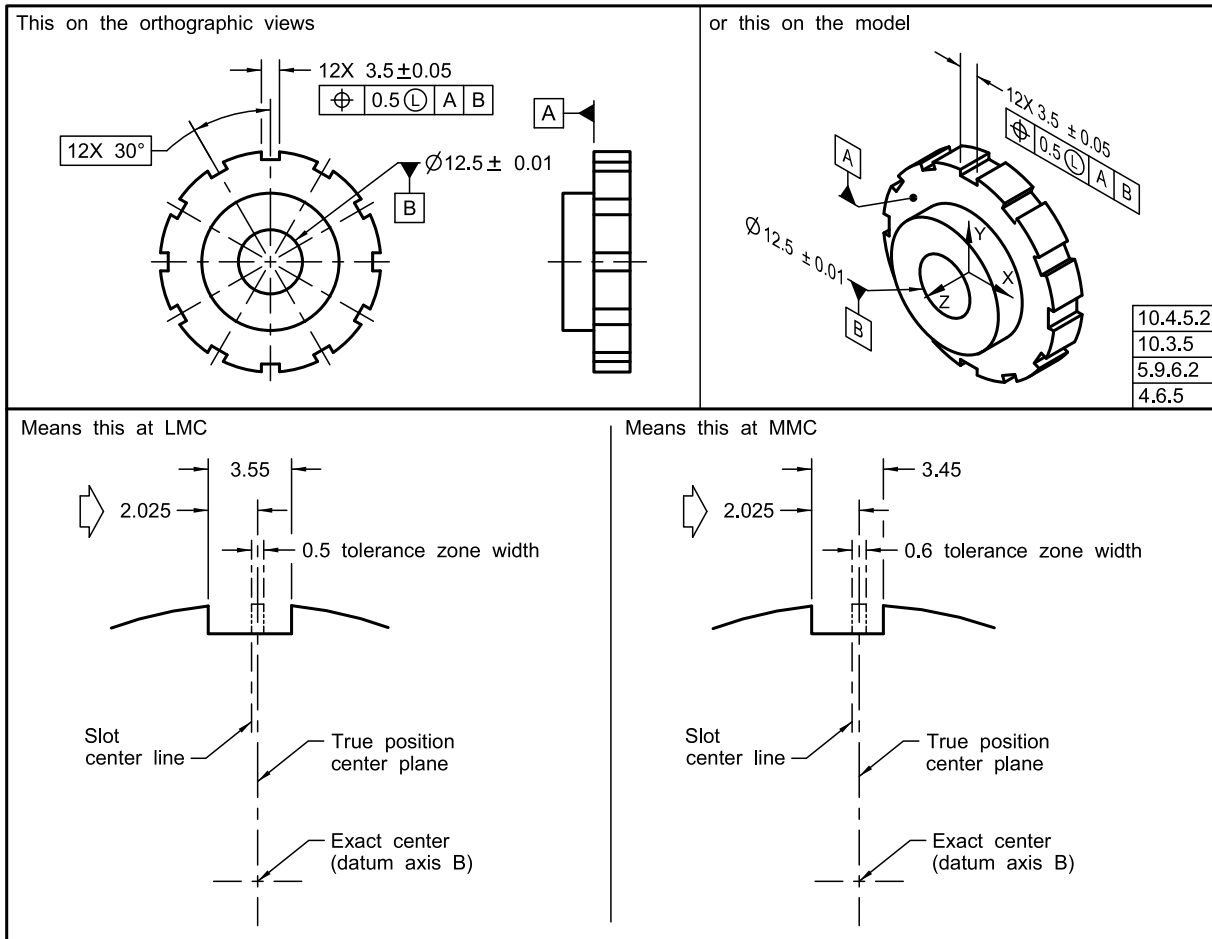

Figure 10-18 Datum Feature at LMB

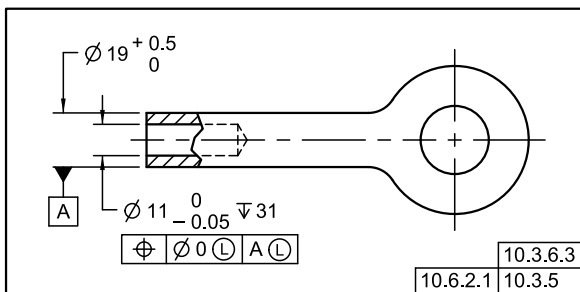
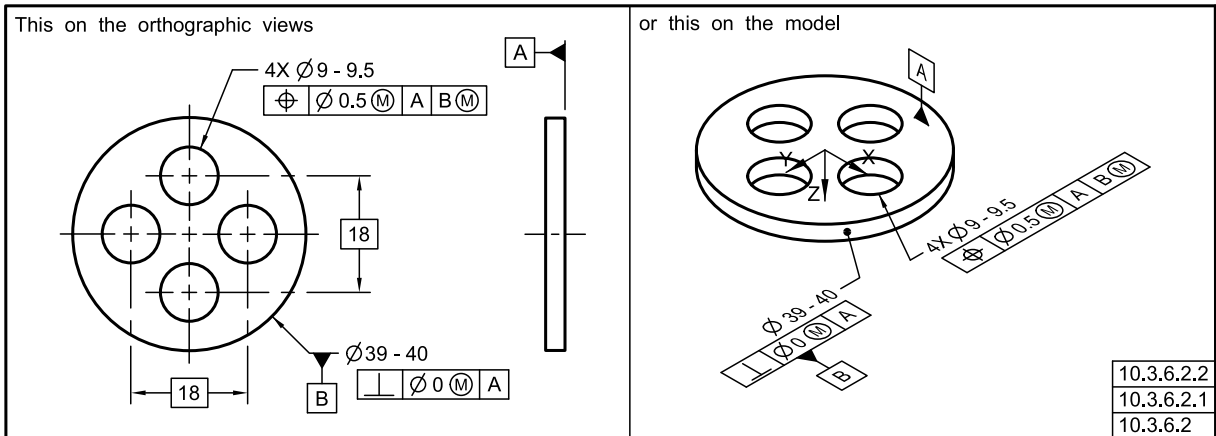
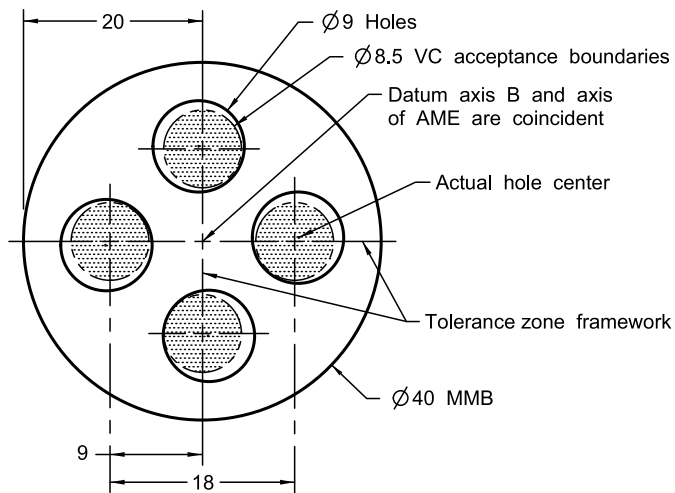

Figure 10-19 Datum Feature Referenced at MMB



Means this



and means this

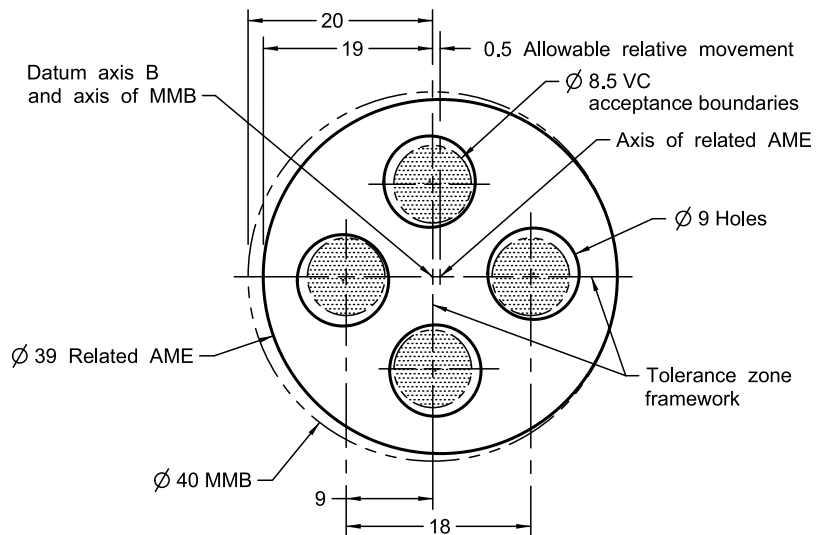

Figure 10-20 Interference Diagram, Fastener and Hole

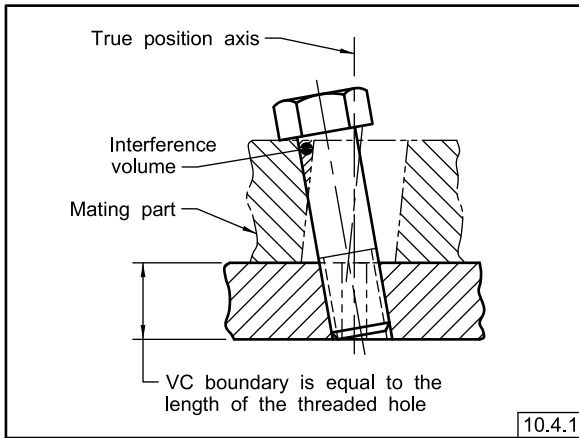

Figure 10-21 Basis for Projected Tolerance Zone

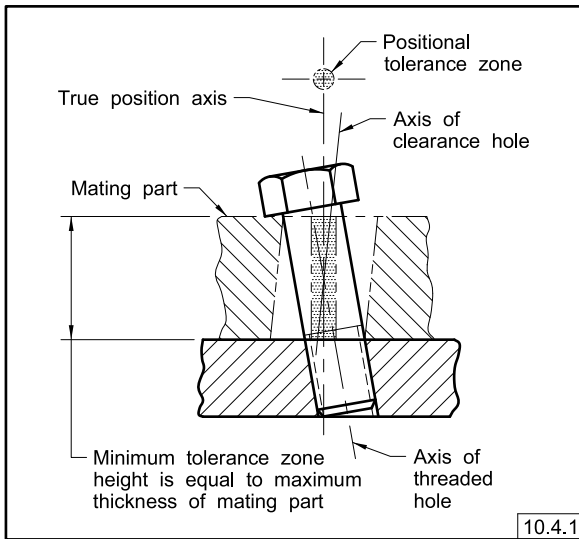

Figure 10-22 Projected Tolerance Zone Specified

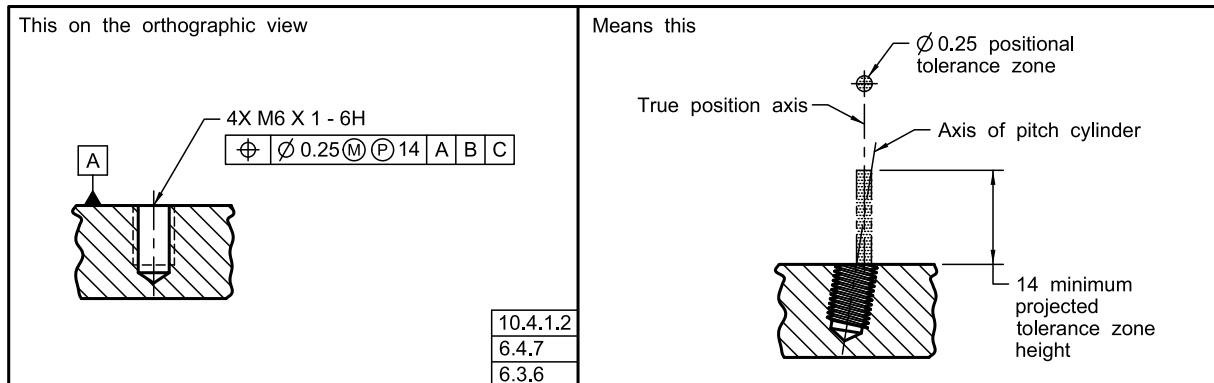

Figure 10-23 Projected Tolerance Zone Indicated With Chain Line

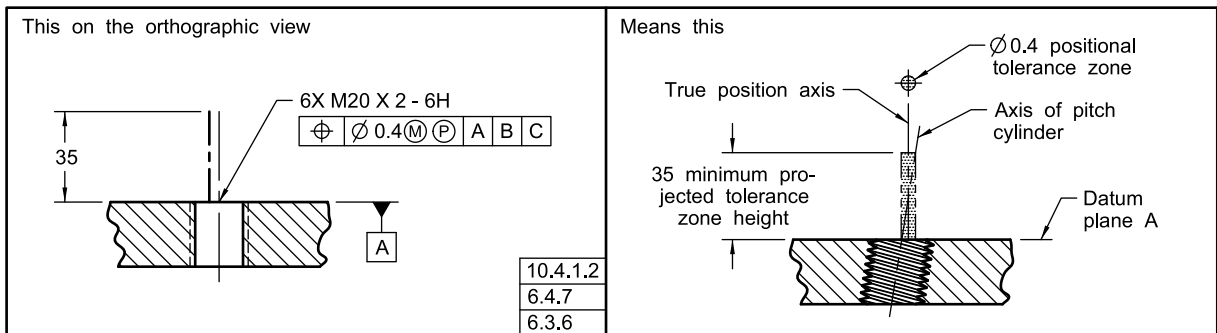

Figure 10-24 Projected Tolerance Zone Applied for Studs or Dowel Pins

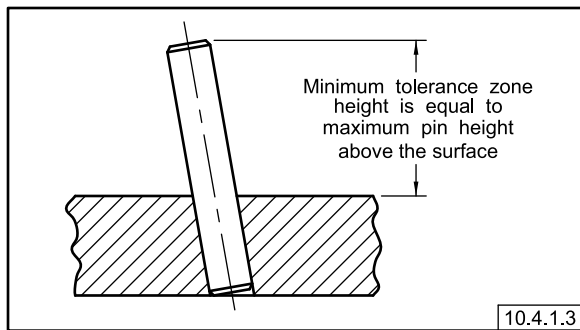

Figure 10-25 Same Positional Tolerance for Holes and Counterbores, Same Datum References

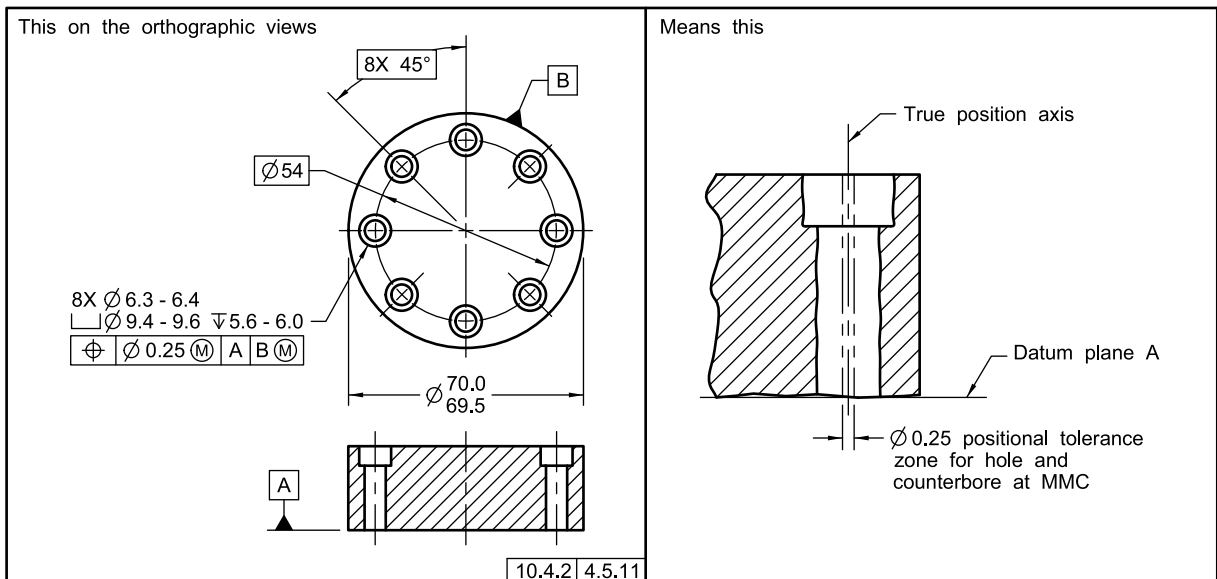

Figure 10-26 Different Positional Tolerances for Holes and Counterbores, Same Datum References

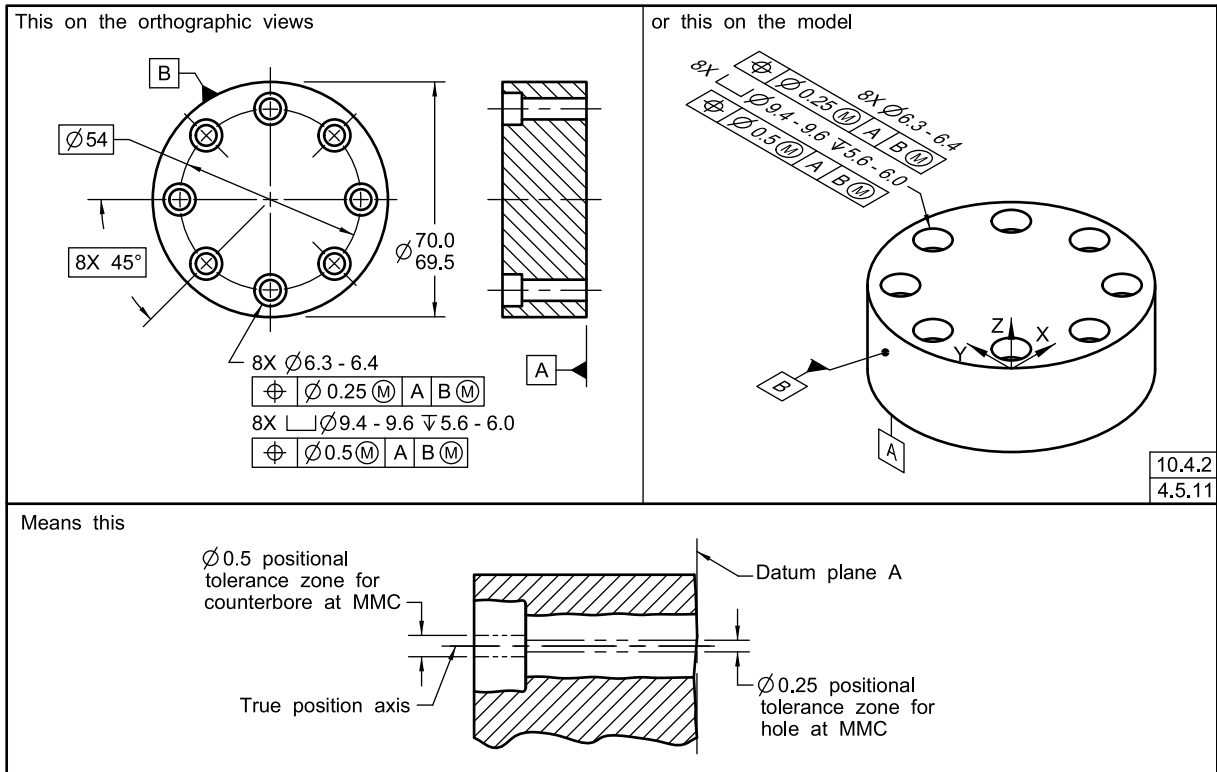

Figure 10-27 Positional Tolerances for Holes and Counterbores, Different Datum References

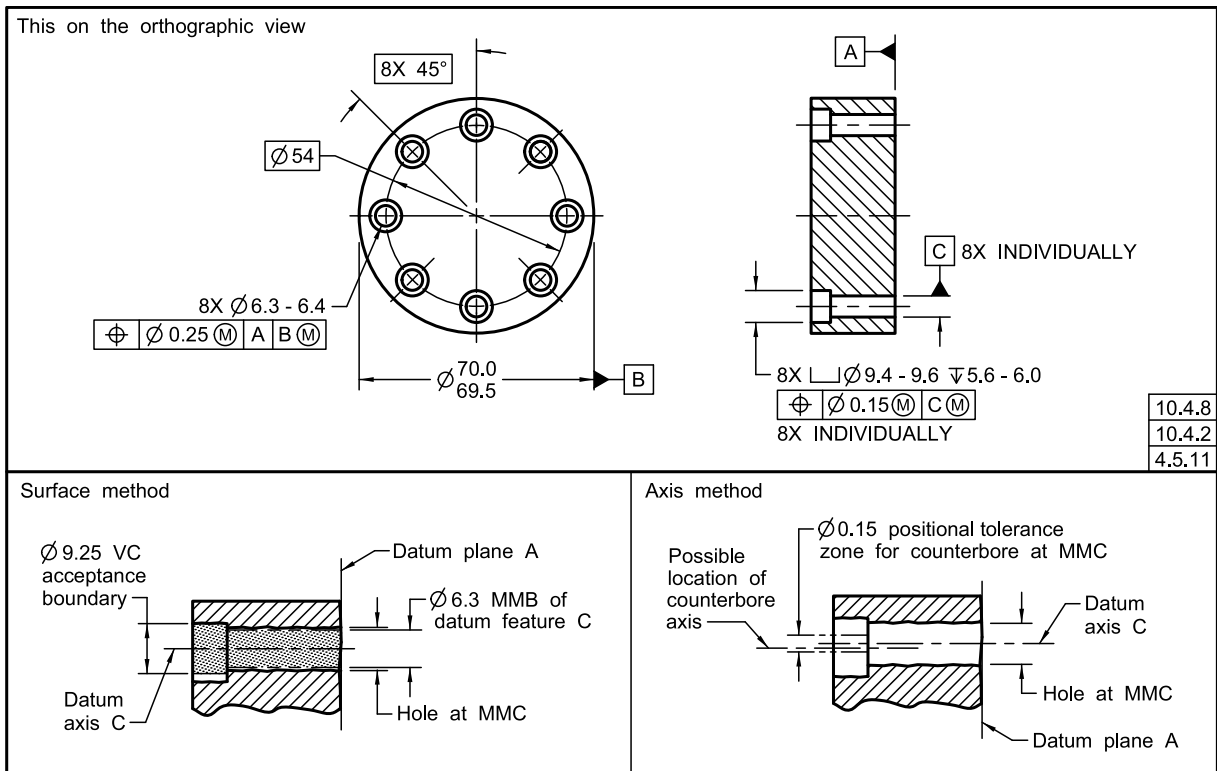

Figure 10-28 Different Positional Tolerance at Each End of a Long Hole

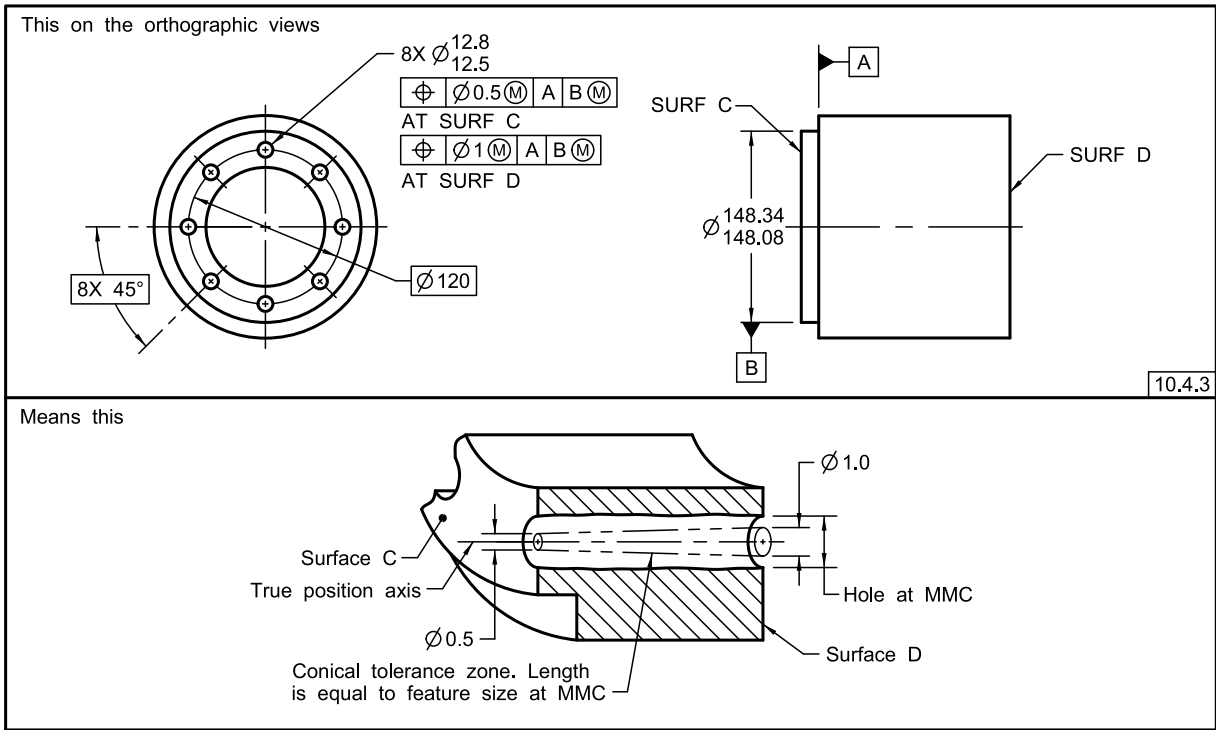

Figure 10-29 Bidirectional Positional Tolerancing, Rectangular Coordinate Method

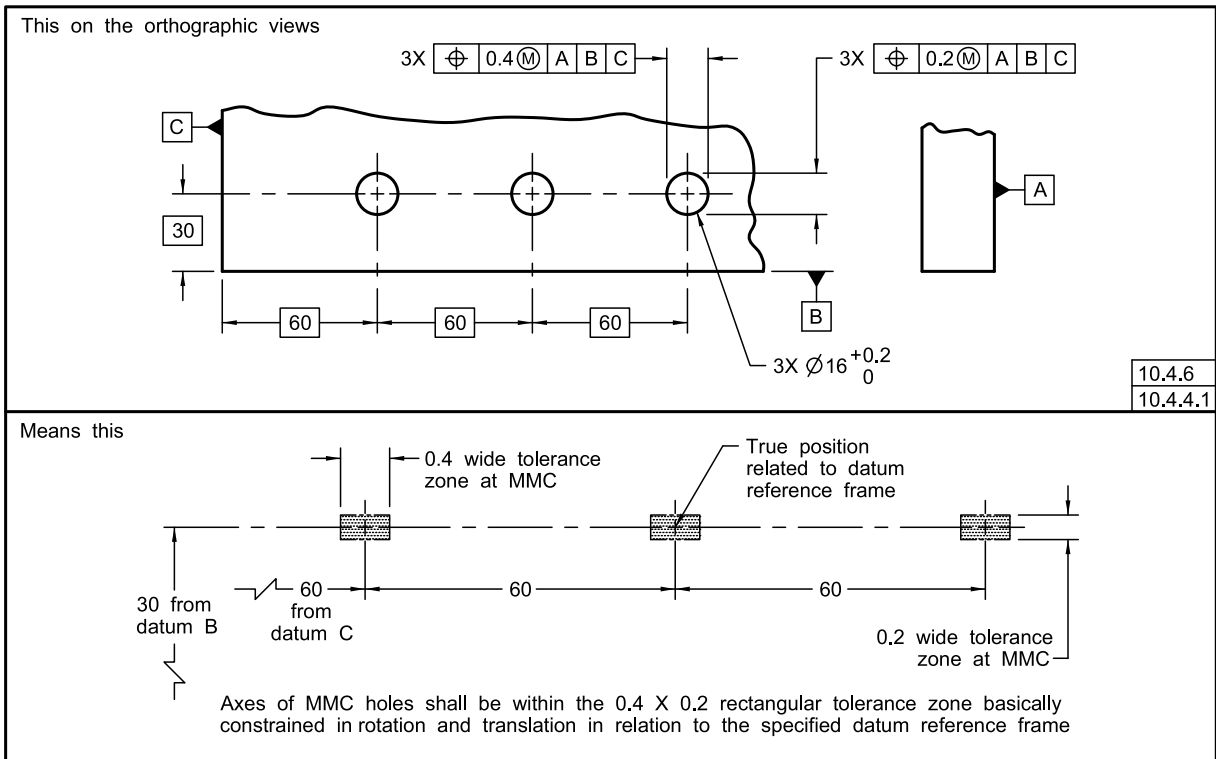

Figure 10-30 Bidirectional Positional Tolerancing, Polar Coordinate Method

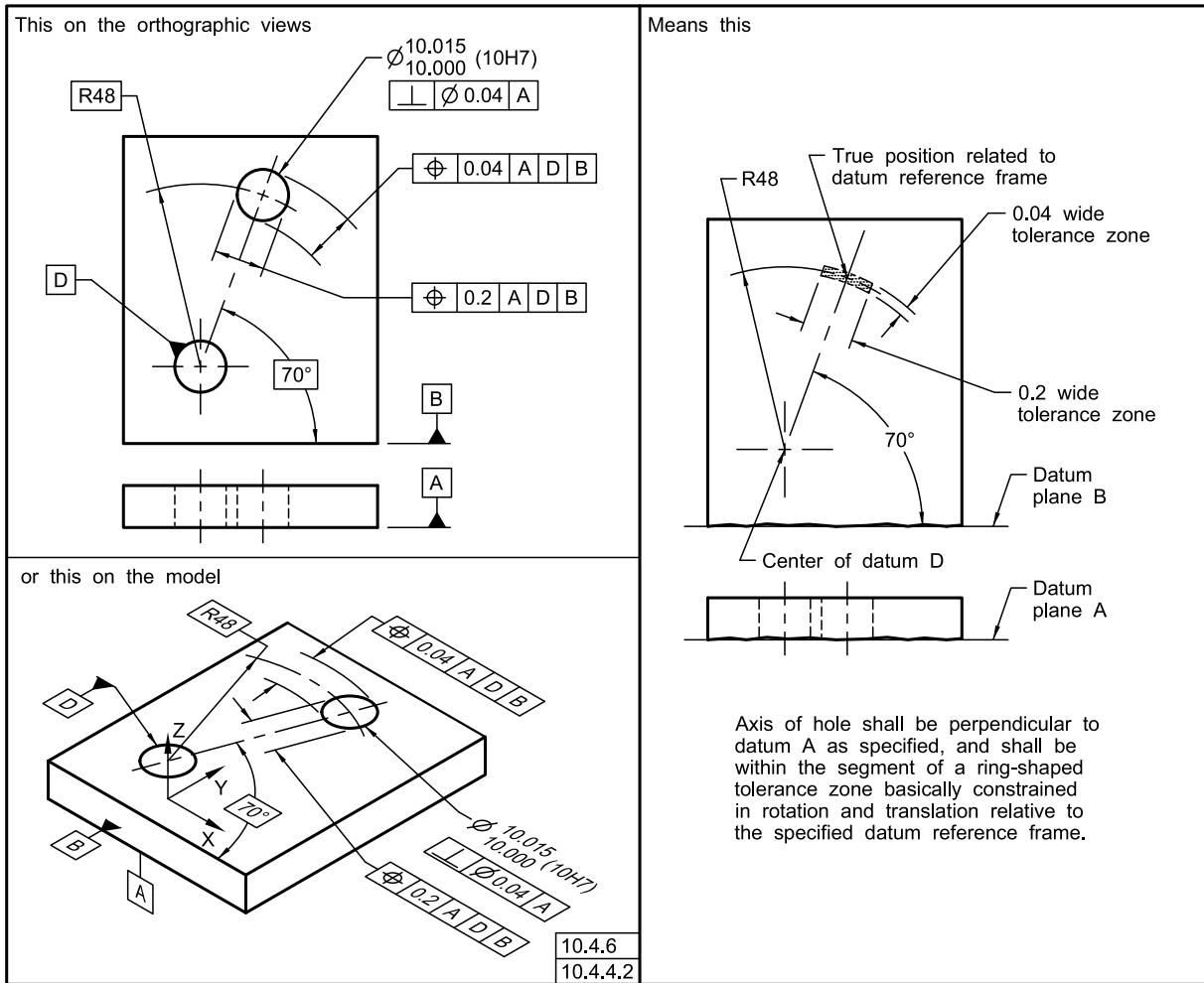

Figure 10-31 Positional Tolerancing of Tabs

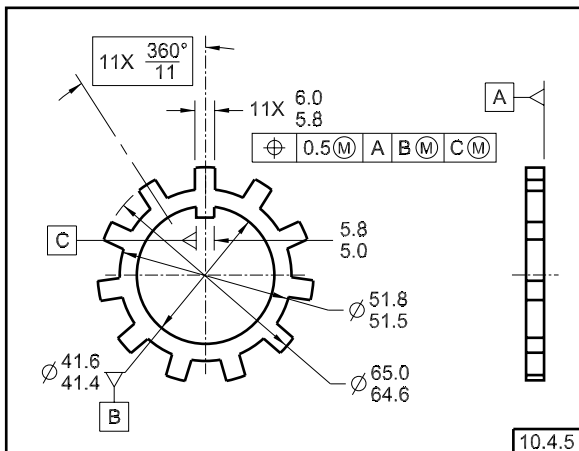

Figure 10-32 Positional Tolerancing of Slots

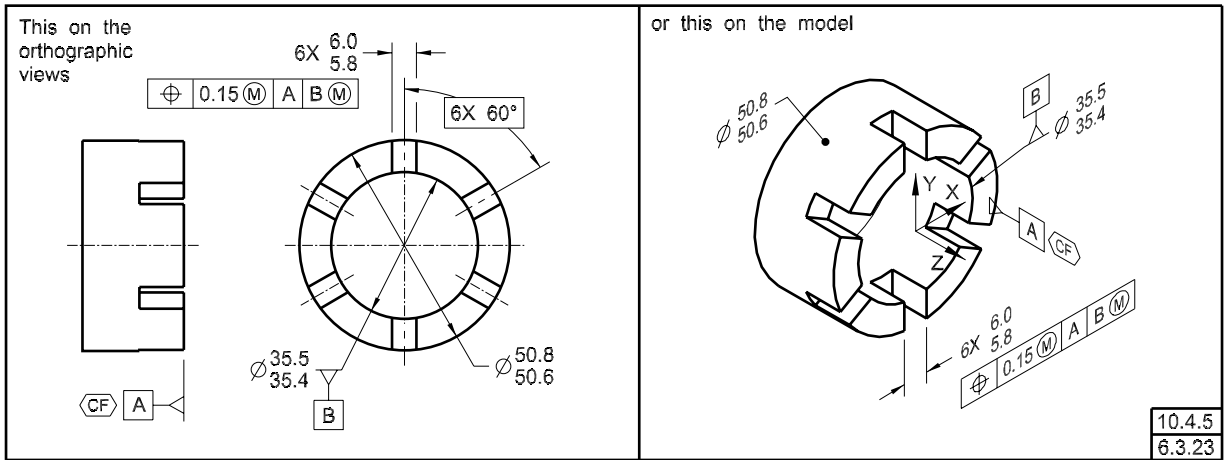

Figure 10-33 Virtual Condition for Surfaces of Slot at MMC

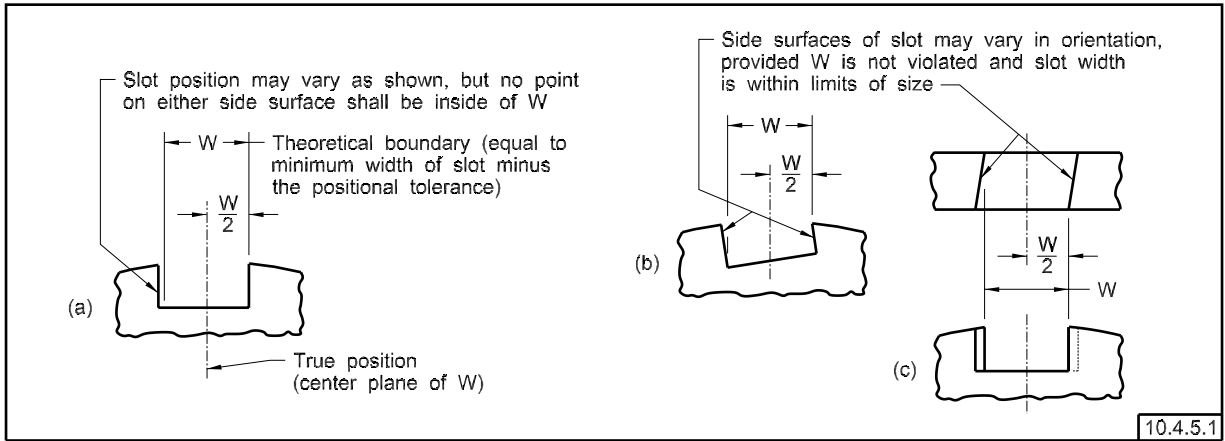

Figure 10-34 Tolerance Zone for Center Plane of Slot at MMC

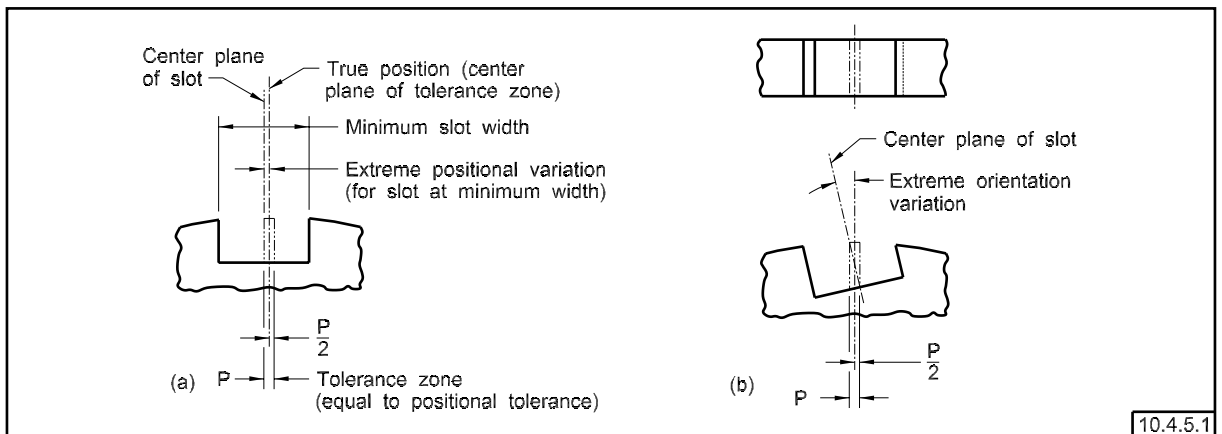
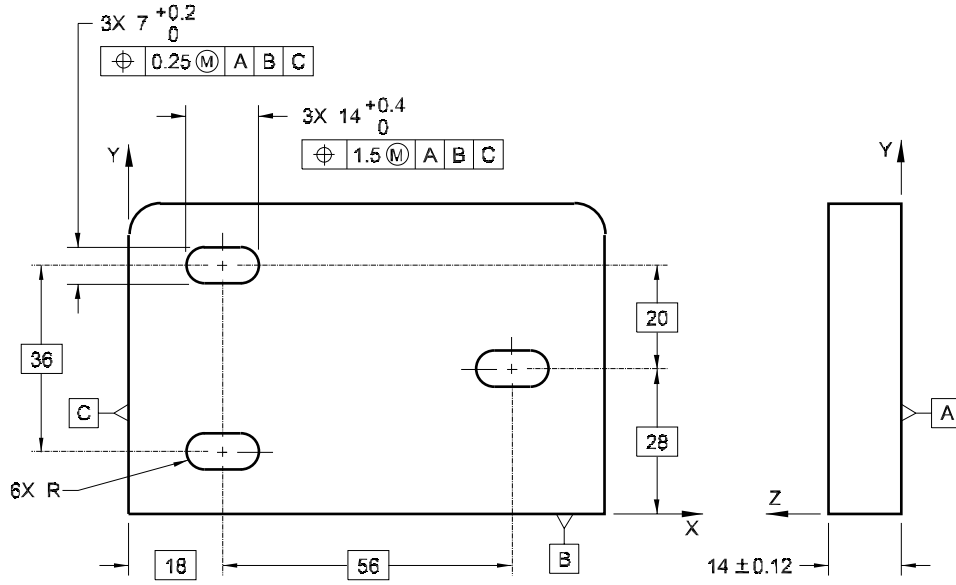
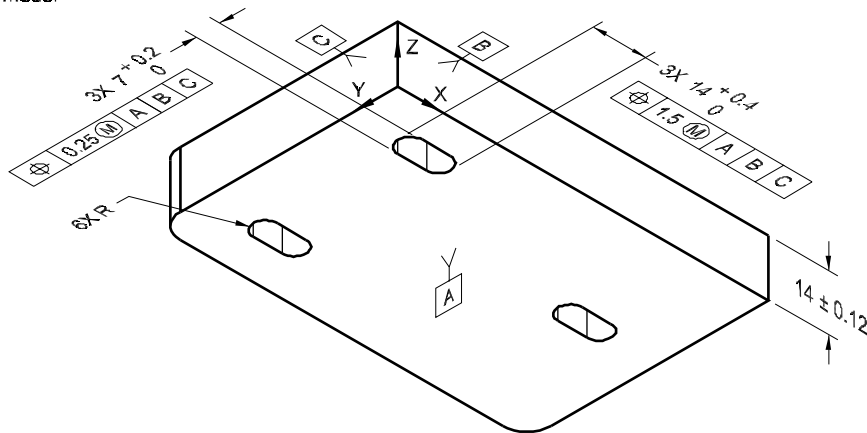

Figure 10-35 Positional Tolerancing, Boundary Concept

This on the orthographic views



or this on the model



10.4.5.1

Figure 10-35 Positional Tolerancing, Boundary Concept (Cont'd)

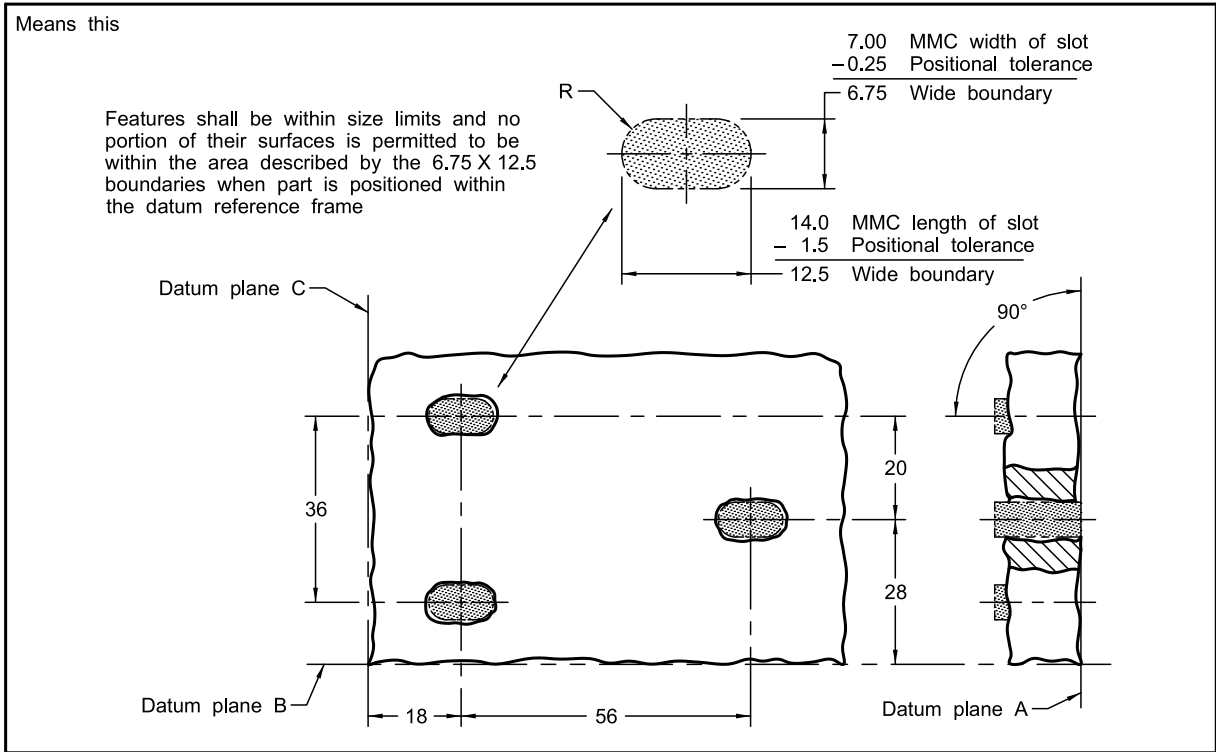
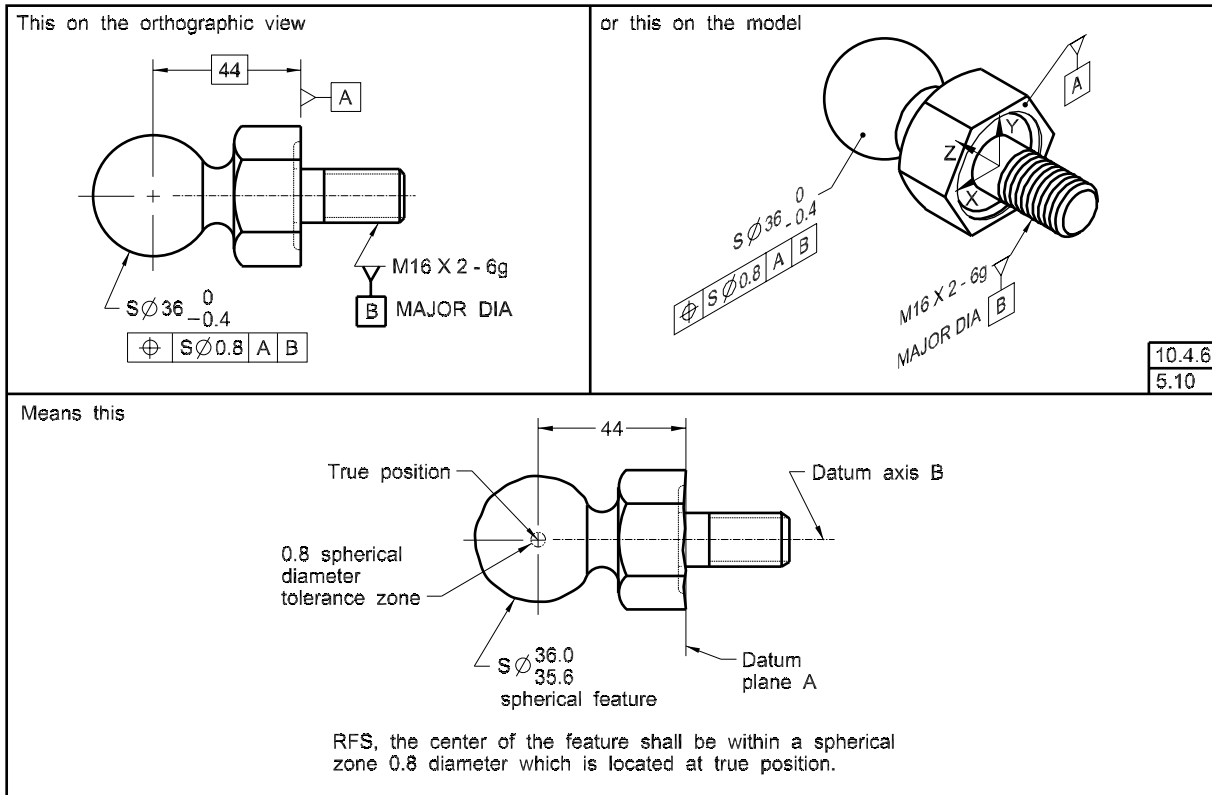

Figure 10-36 Spherical Feature Located by Positional Tolerancing



10.4.6
5.10

Figure 10-37 Nonparallel Holes Including Those Not Normal to the Surface

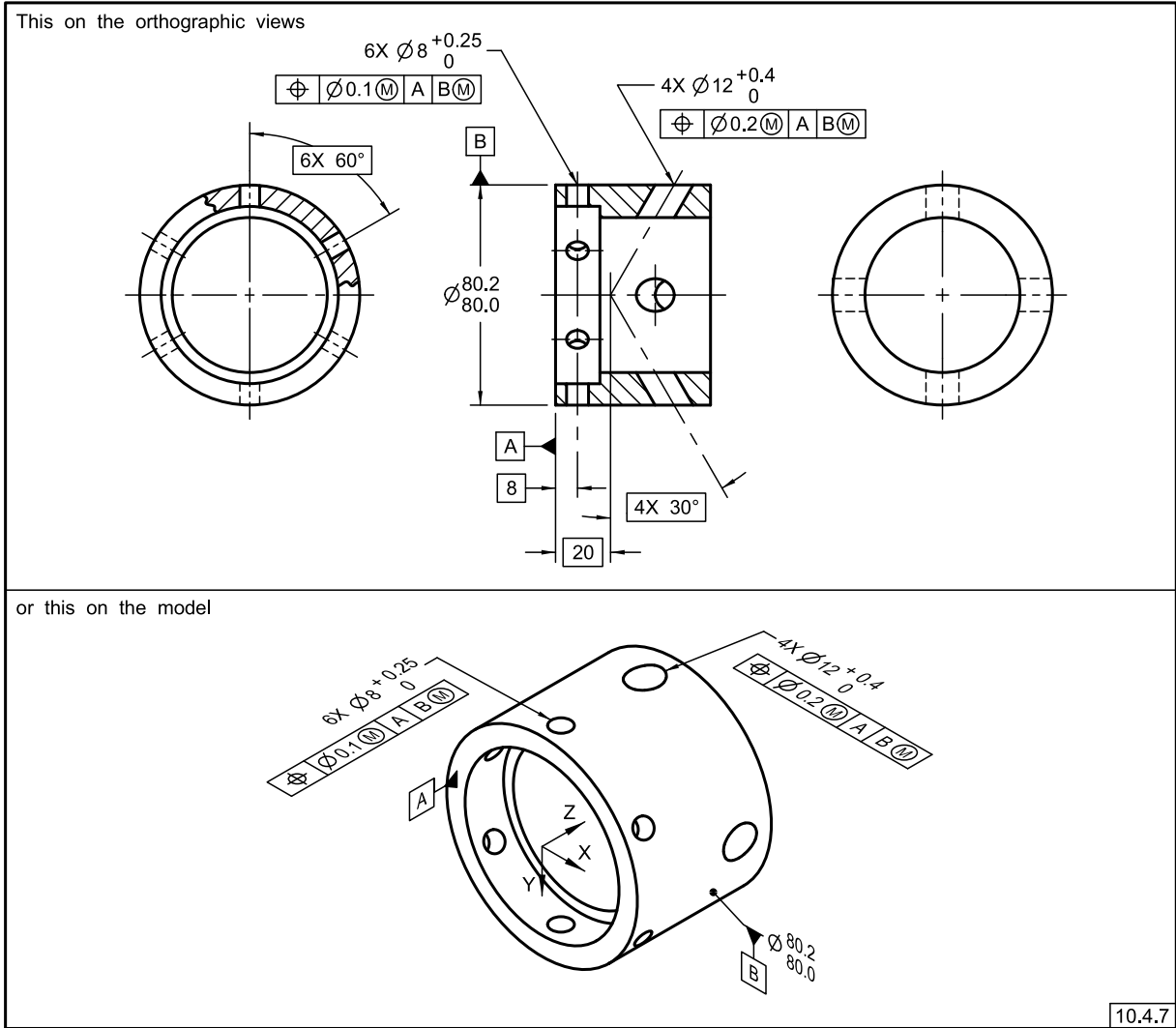

Figure 10-38 Multiple Patterns of Features

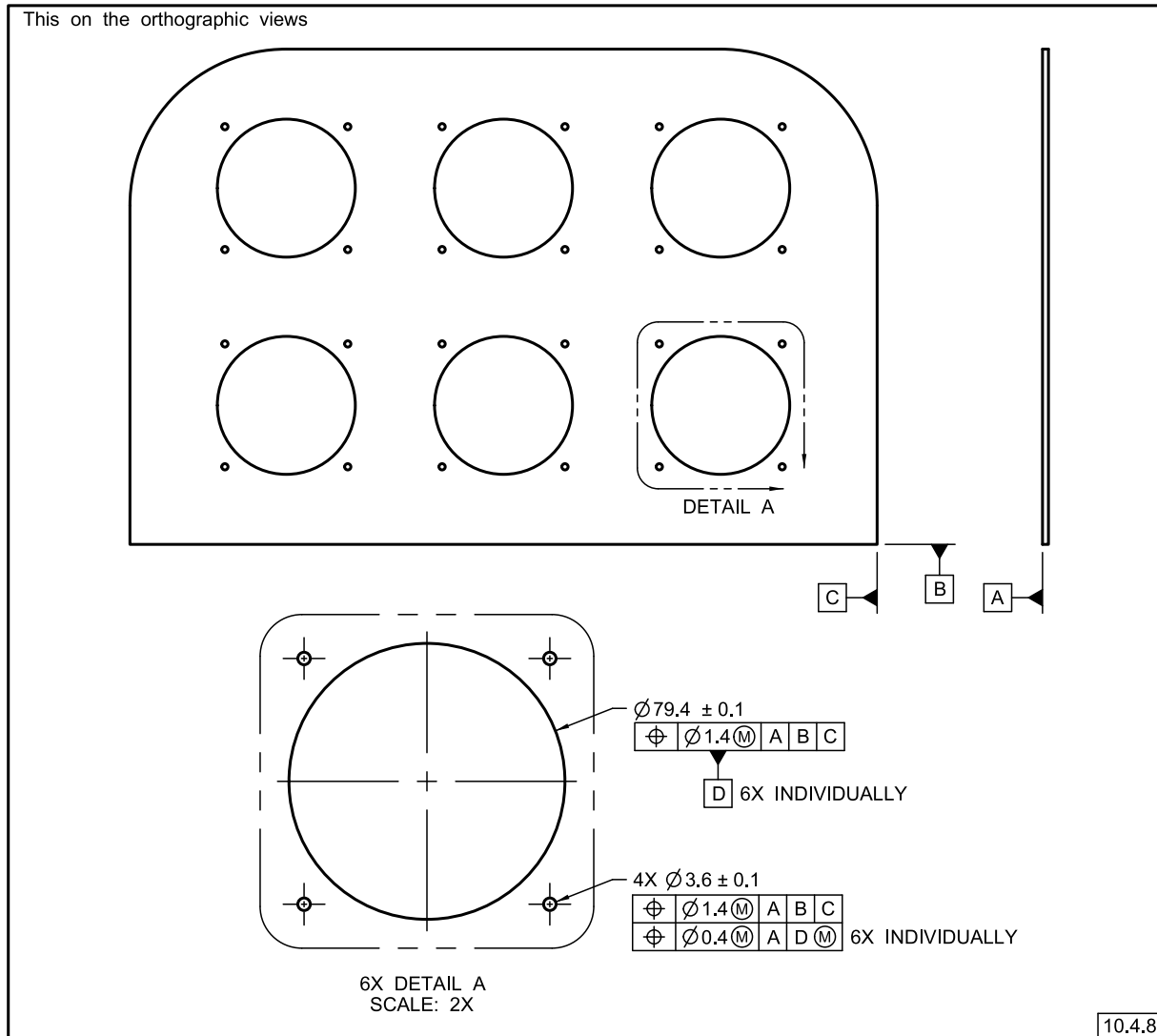

Figure 10-38 Multiple Patterns of Features (Cont'd)

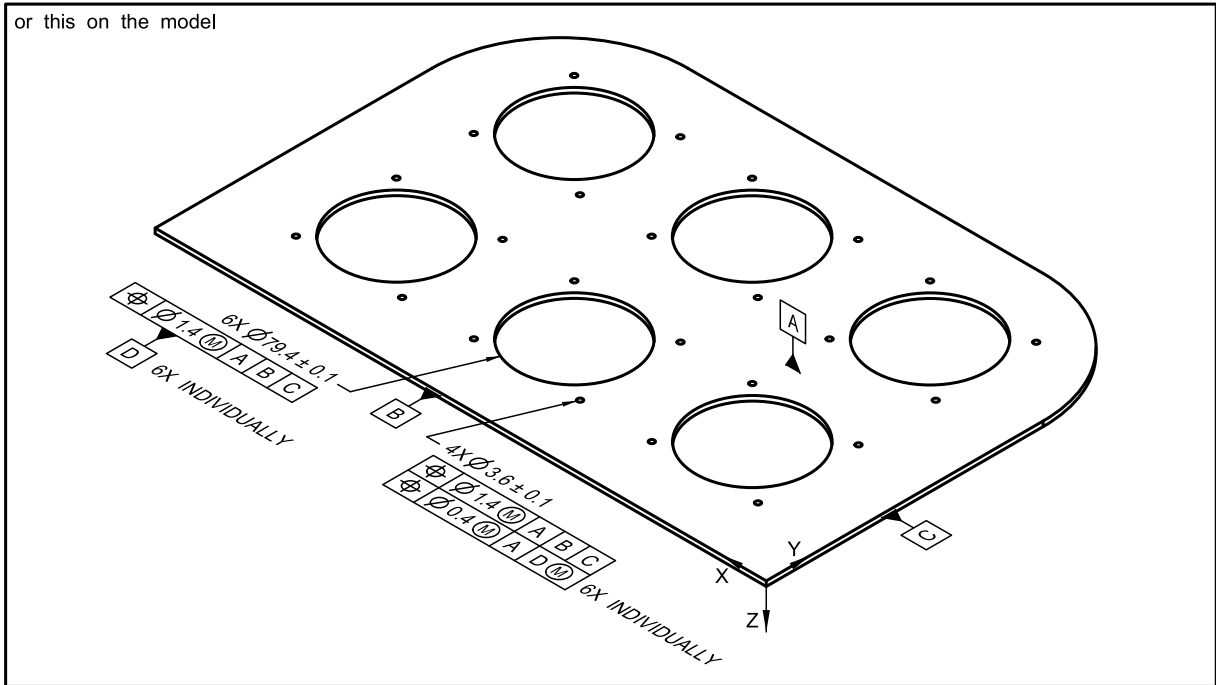
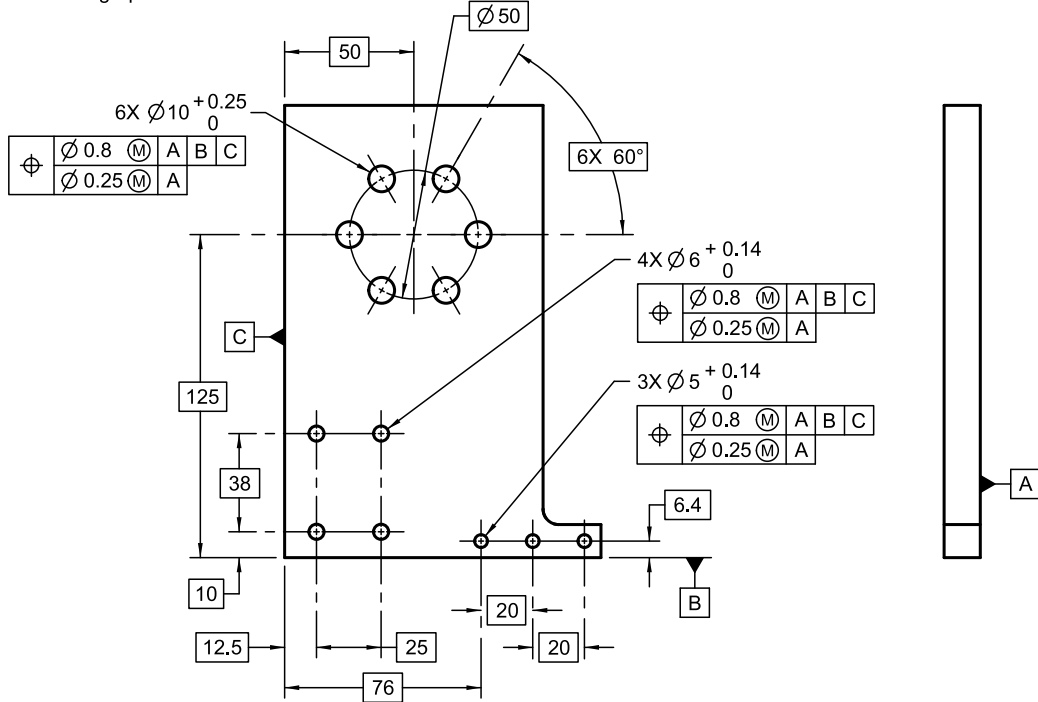
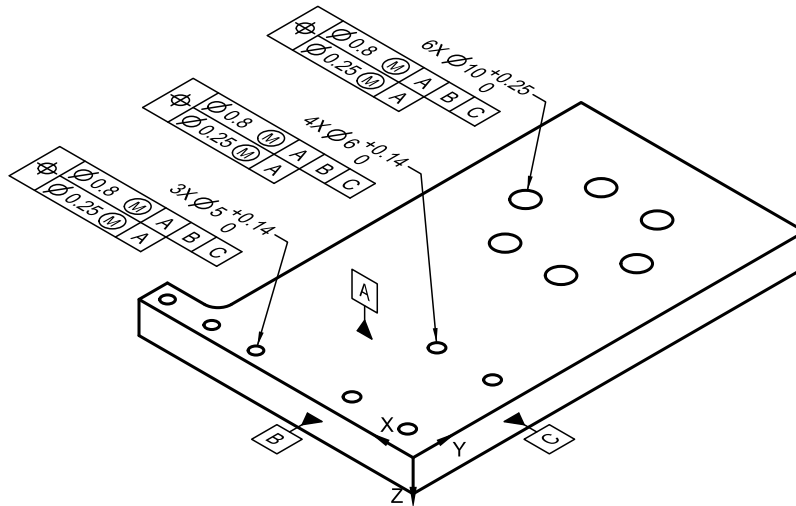

Figure 10-39 Hole Patterns Located by Composite Positional Tolerancing

This on the orthographic views



or this on the model



10.5.1.3
10.5.1.2
10.5.1.1
10.5.1

Figure 10-39 Hole Patterns Located by Composite Positional Tolerancing (Cont'd)

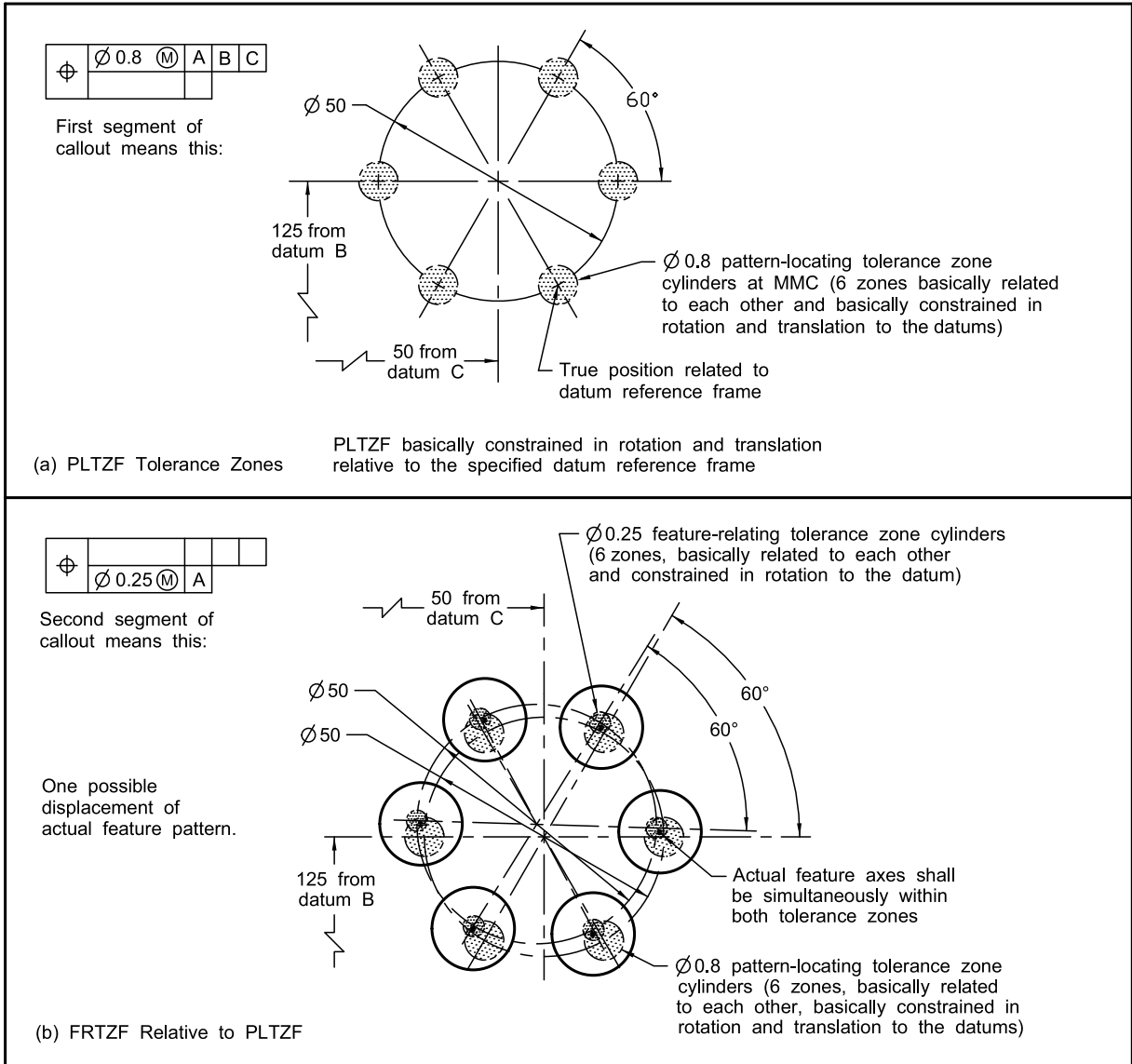

Figure 10-39 Hole Patterns Located by Composite Positional Tolerancing (Cont'd)

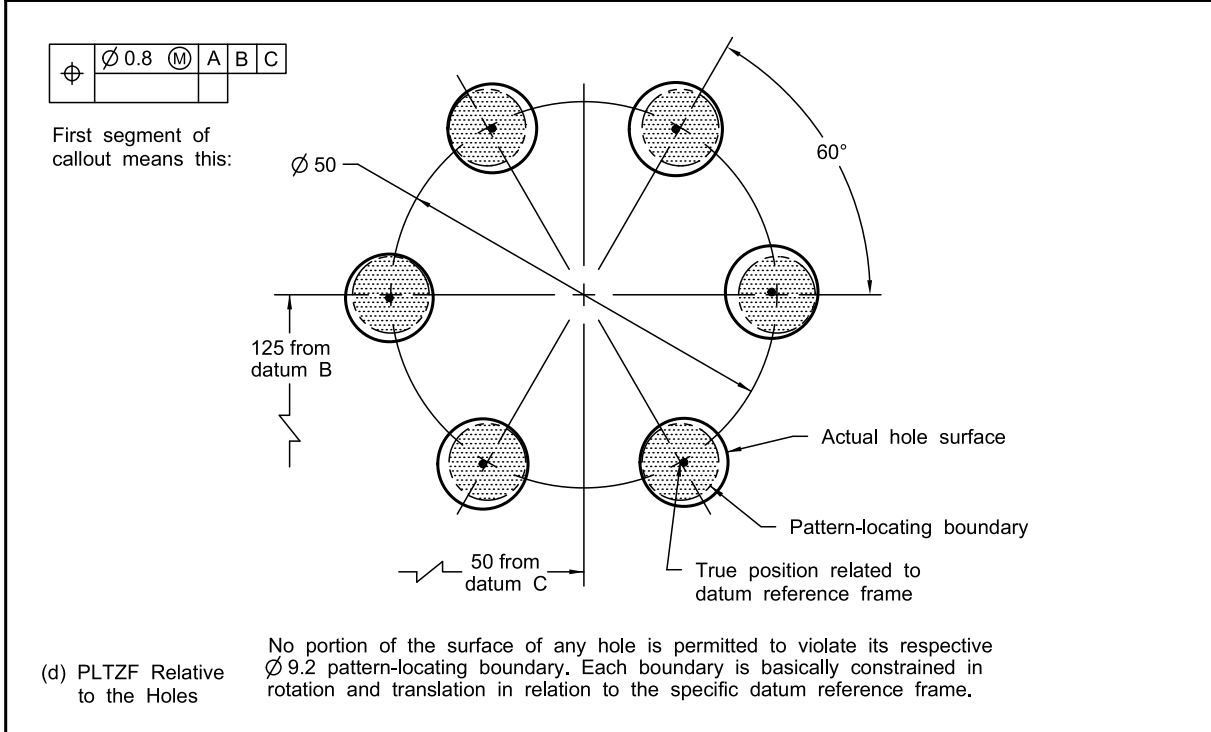
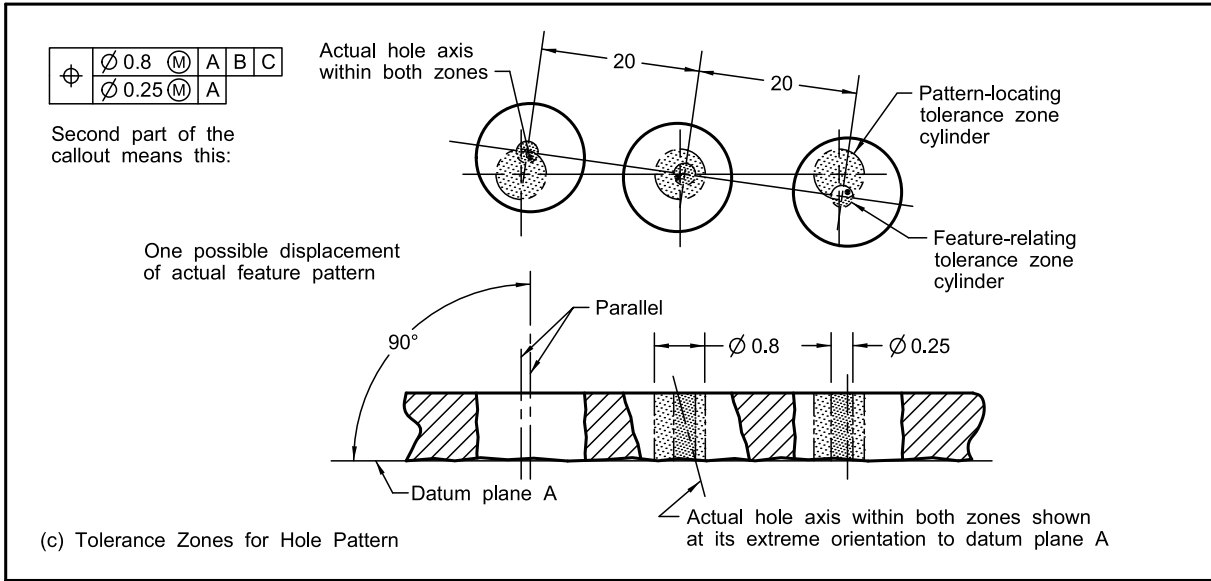

Figure 10-39 Hole Patterns Located by Composite Positional Tolerancing (Cont'd)

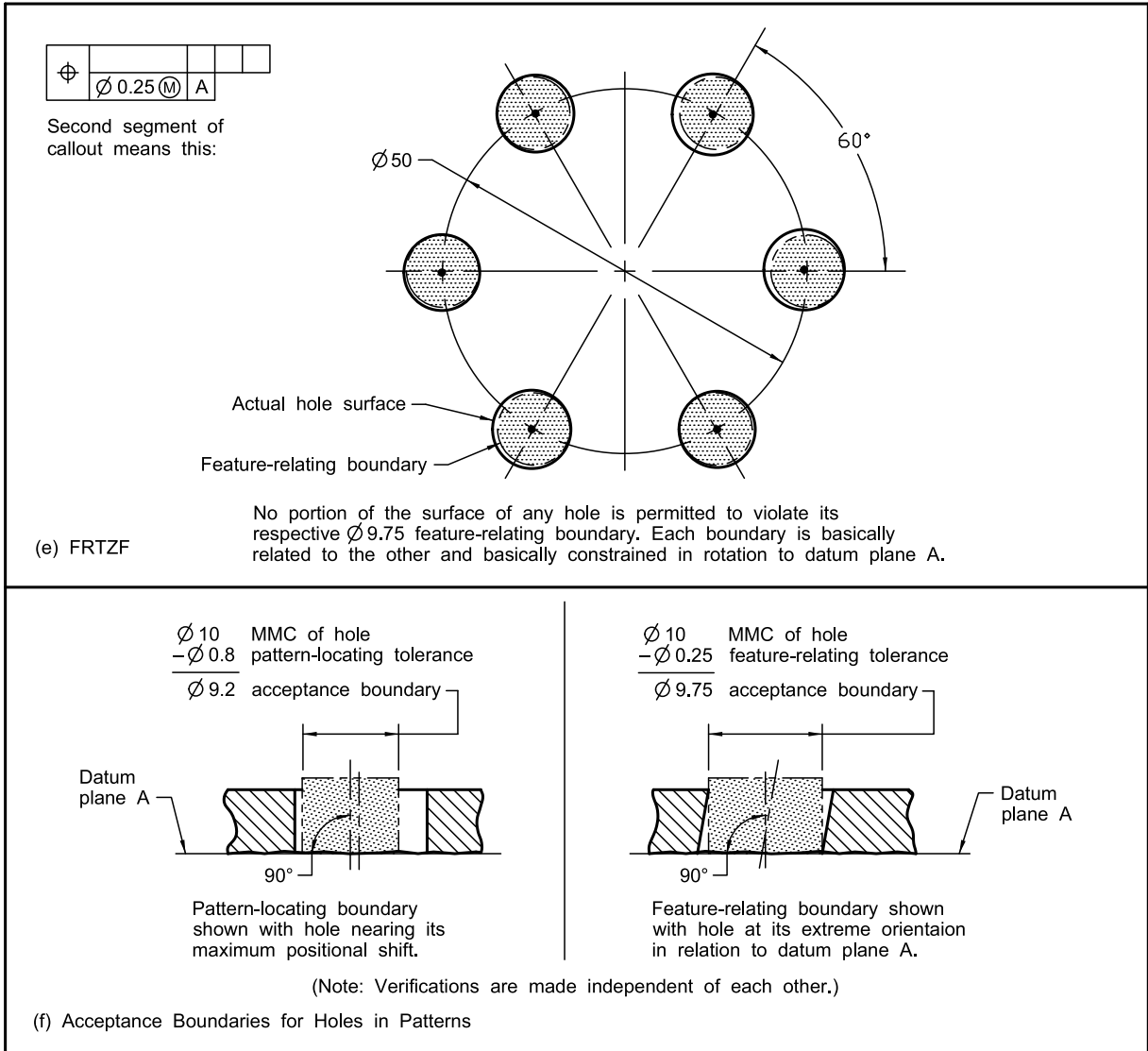

Figure 10-40 Hole Patterns of Figure 10-38 With Secondary Datums in Feature-Relating Segments of Composite Feature Control Frames

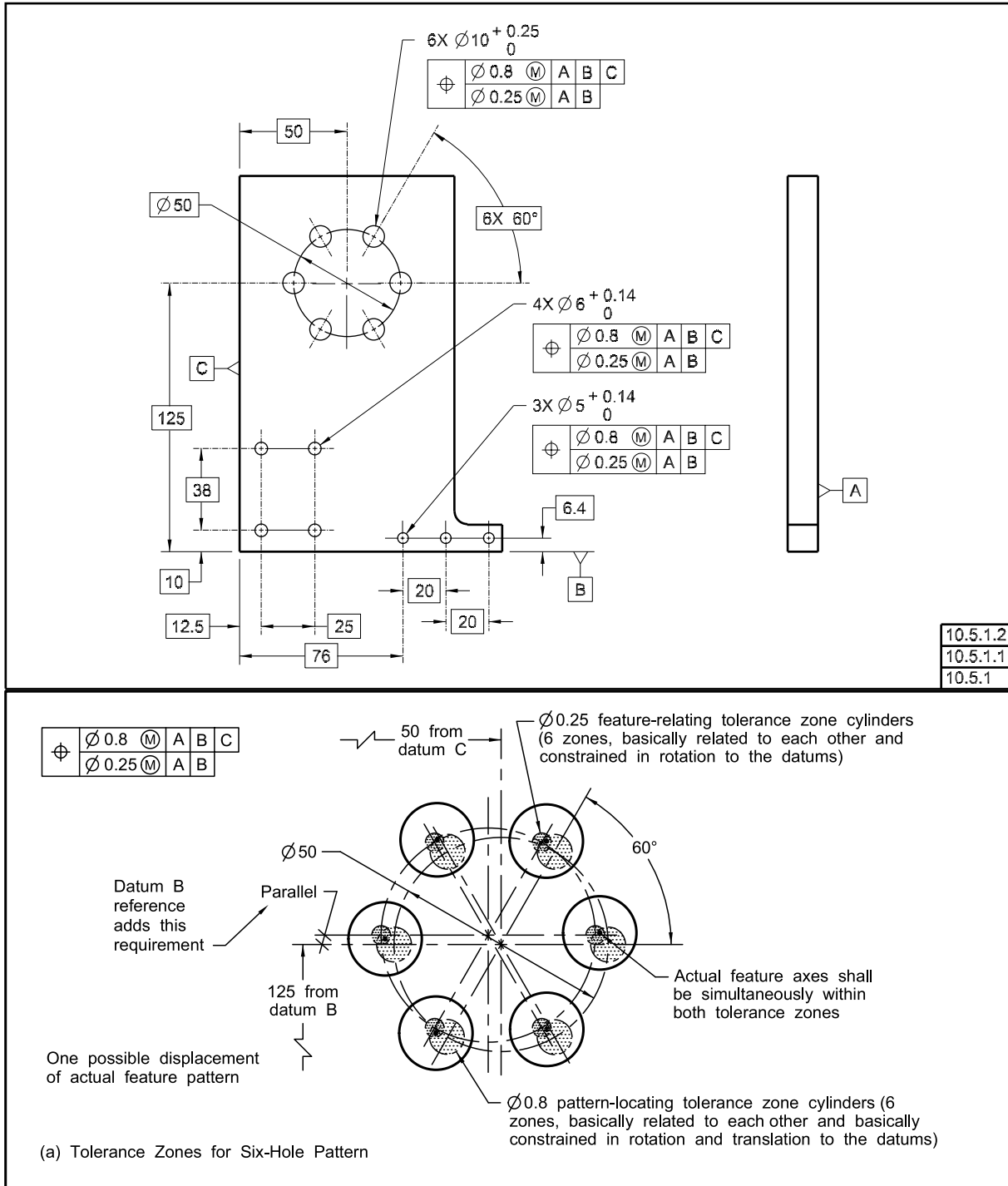
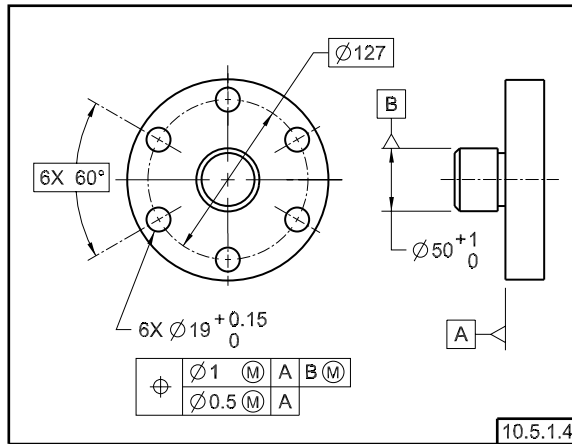

Figure 10-41 Composite Positional Tolerancing of a Circular Pattern of Features



⊕	∅1	(M)	A	B	(M)
	∅0.5	(M)	A		

First segment of callout means this:

PLTZF $\varnothing 1$ tolerance cylinders are basically constrained in rotation and translation relative to each other and to the specified datum reference frame.

Datum axis B
 $\varnothing 1$ pattern-locating tolerance zone cylinders

Datum plane A

(a) PLTZF

⊕	∅0.5	(M)	A		

Second segment of callout means this:

One possible displacement of the FRTZF relative to the PLTZF

$\varnothing 1$ pattern-locating tolerance zone cylinders

Datum plane A

$\varnothing 0.5$ feature-relating tolerance zone cylinders

(b) FRTZF / PLTZF

Figure 10-42 Radial Hole Pattern Located by Composite Positional Tolerancing — Repeated Primary Datum Reference

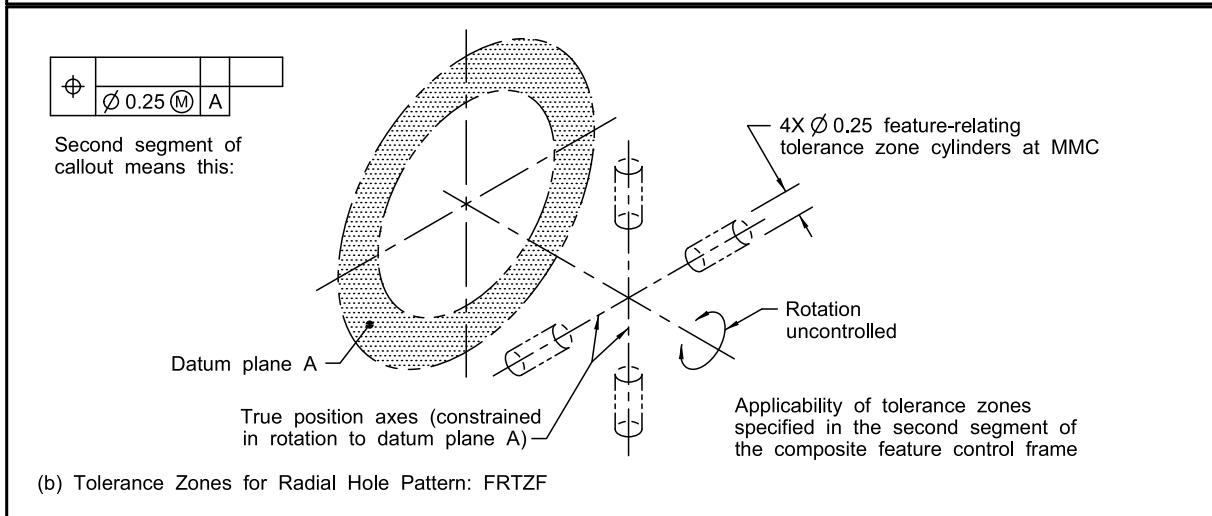
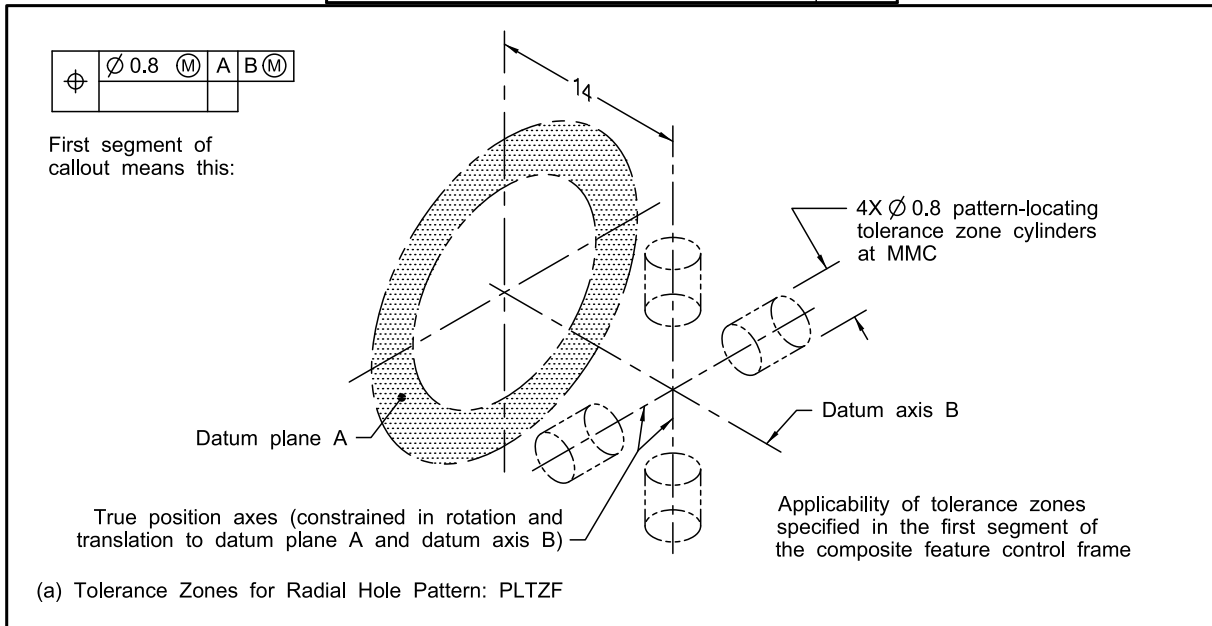
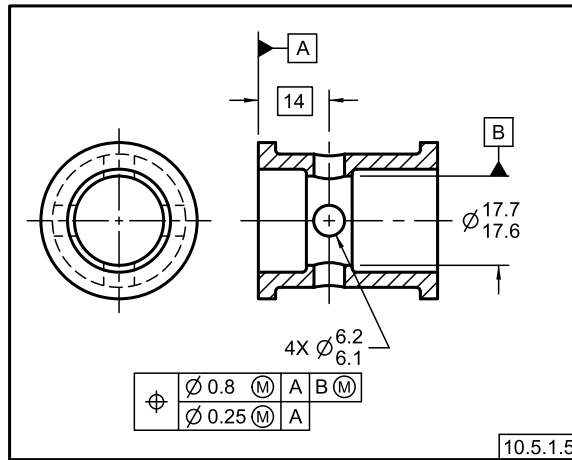

Figure 10-42 Radial Hole Pattern Located by Composite Positional Tolerancing — Repeated Primary Datum Reference (Cont'd)

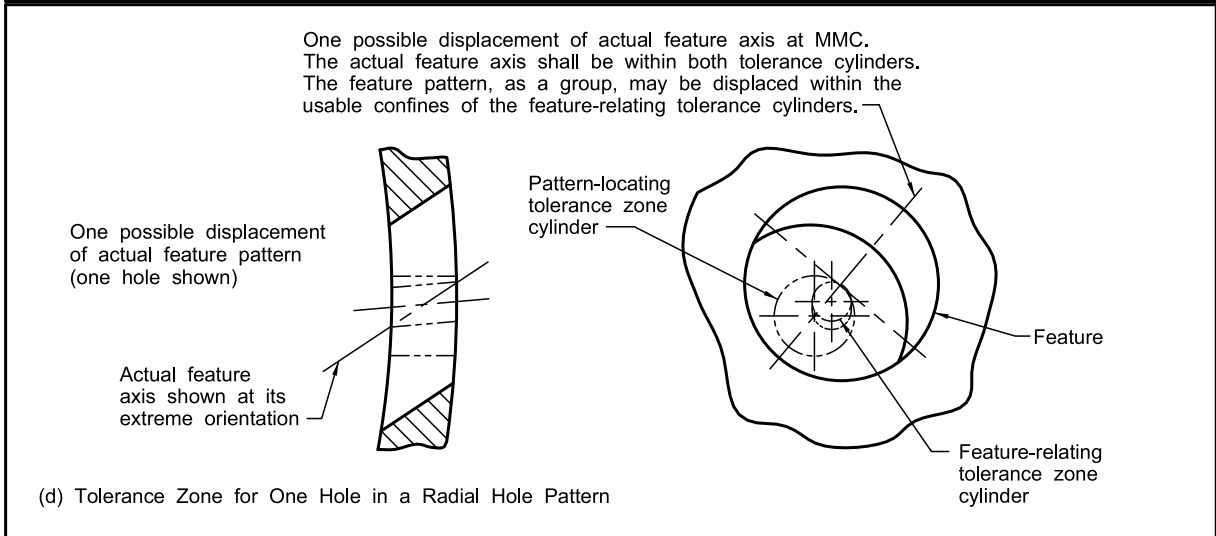
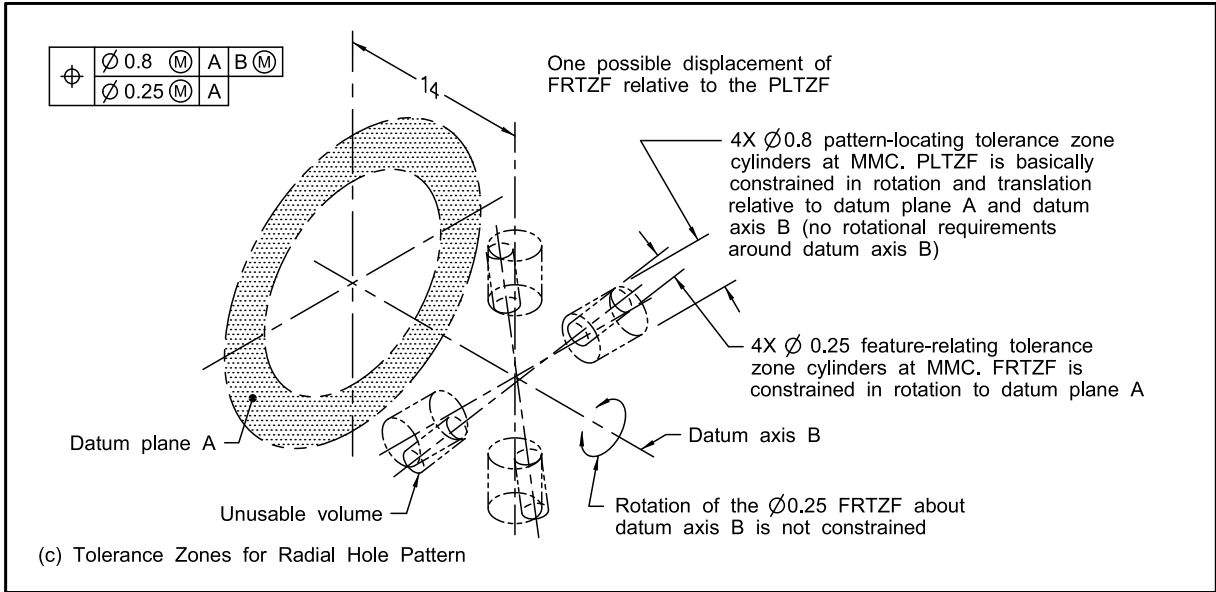

Figure 10-43 Radial Hole Pattern Located by Composite Positional Tolerancing — Repeated All Datum References

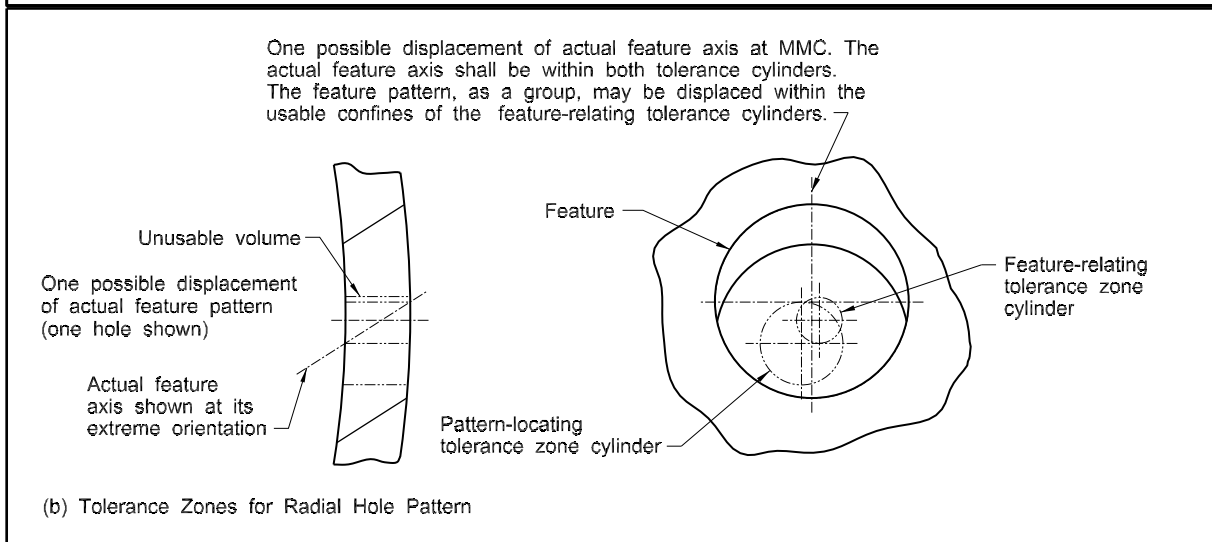
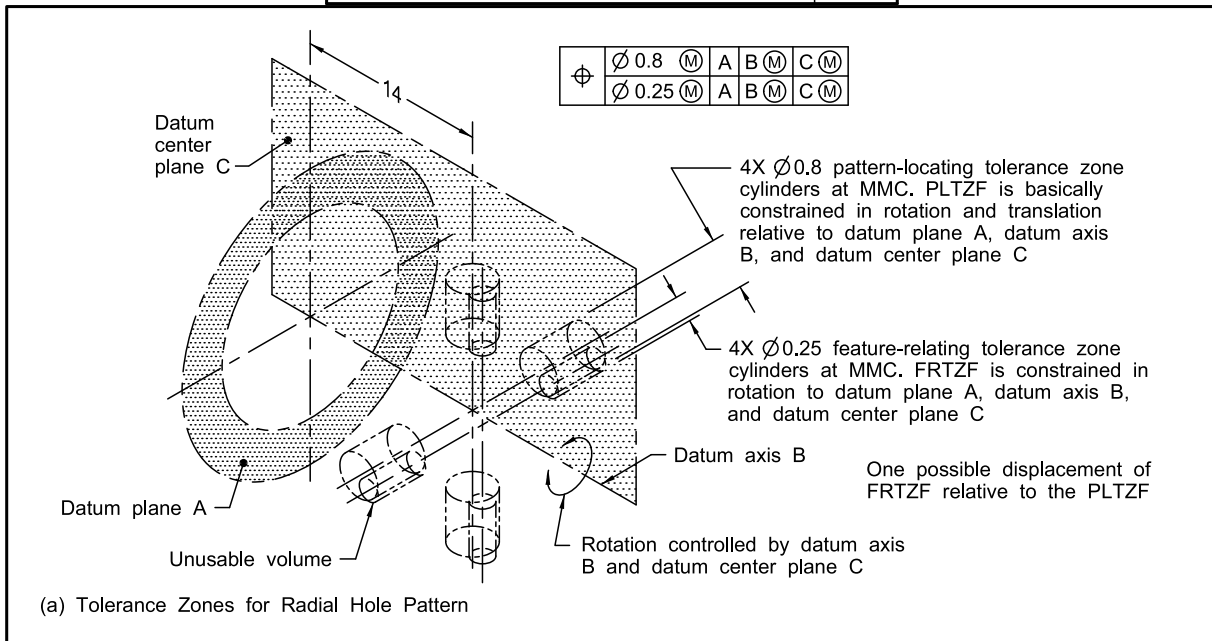
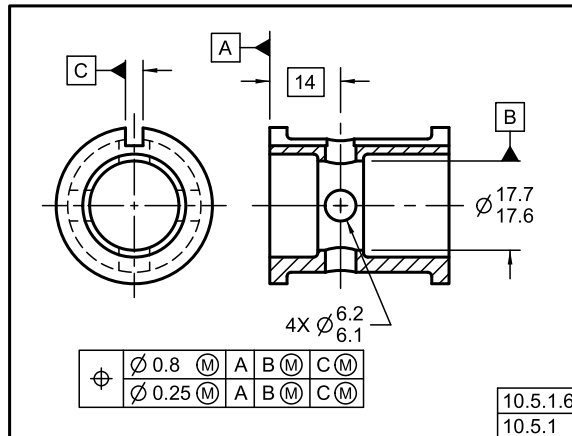

Figure 10-44 Orientation Relative to Three Datum Planes

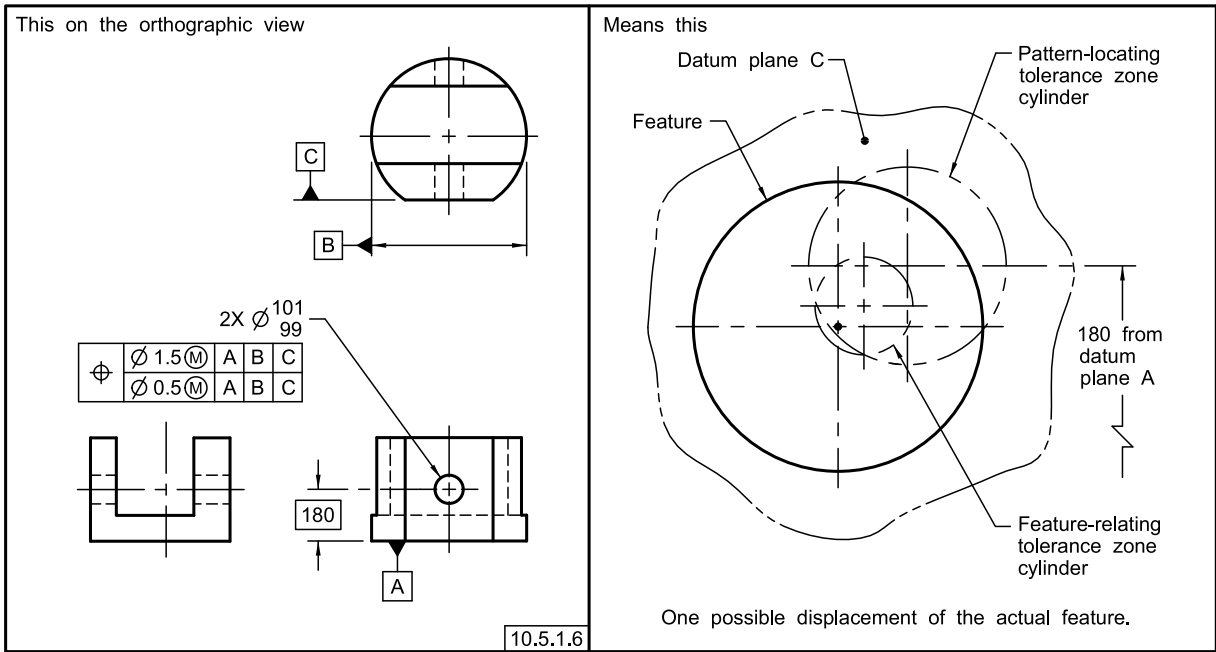
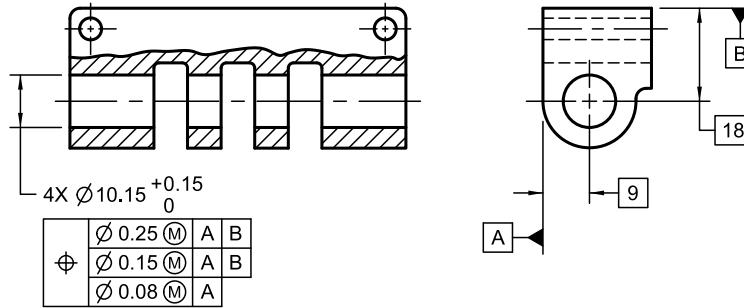
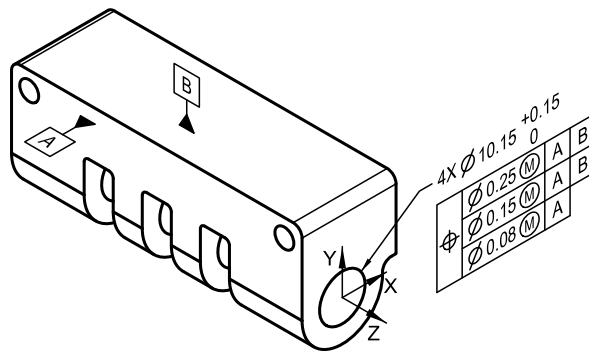

Figure 10-45 Positional Tolerancing for Coaxial Holes of Same Size, Partial (Parallelism) Refinement of Feature-Relating Axis Relative to Datums A and B With Further Refinement of Parallelism to Datum A

This on the orthographic views



or this on the model



10.5.1.8

Means this

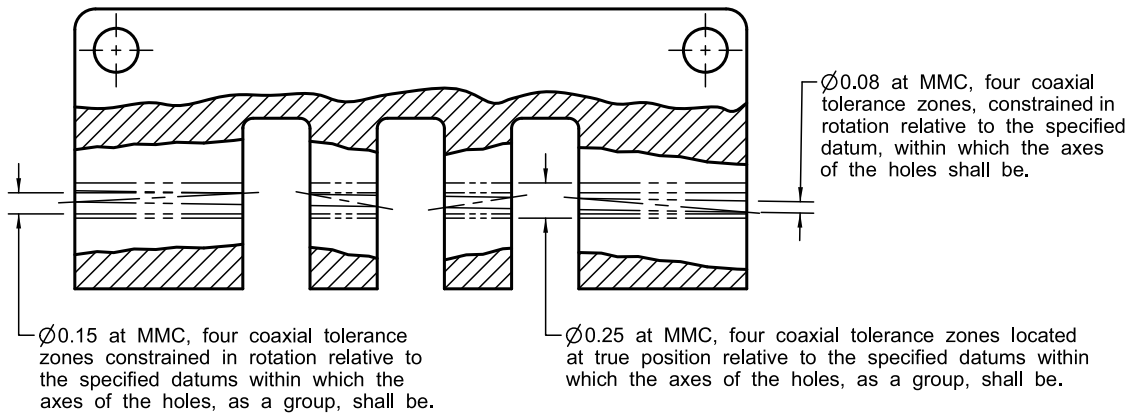

Figure 10-45 Positional Tolerancing for Coaxial Holes of Same Size, Partial (Parallelism) Refinement of Feature-Relating Axis Relative to Datums A and B With Further Refinement of Parallelism to Datum A (Cont'd)

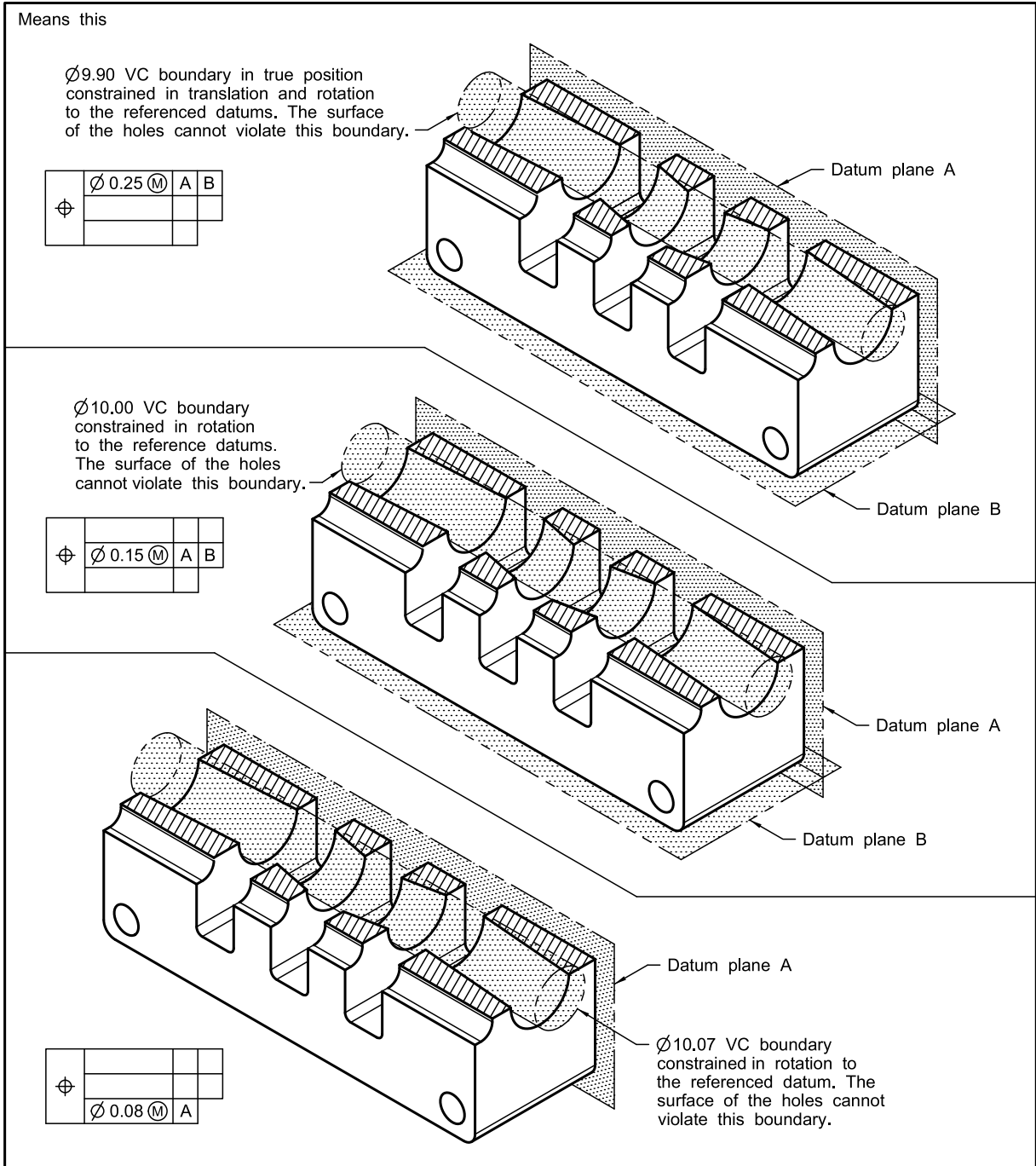

Figure 10-46 Three-Segment Composite Tolerance

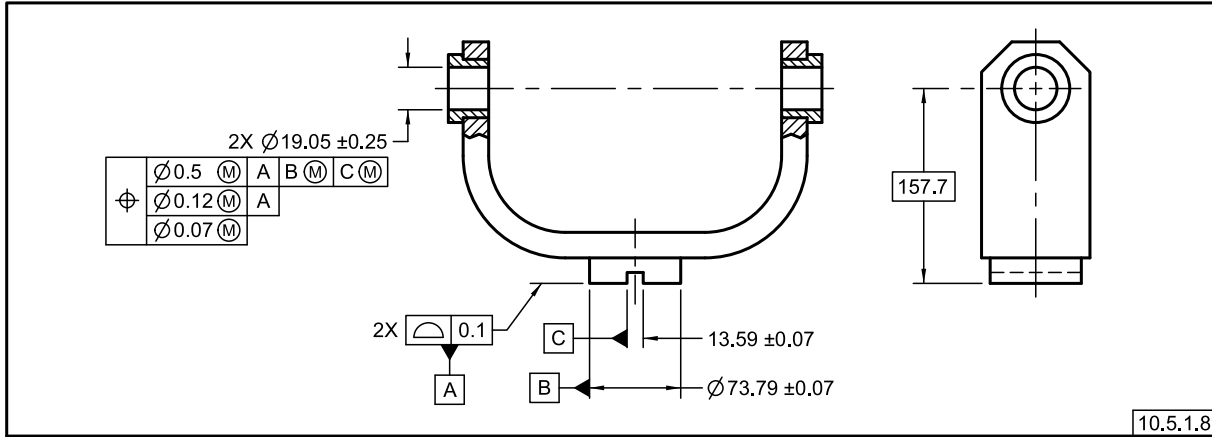

Figure 10-47 Multiple Single-Segment Feature Control Frames With Secondary Datum in Lower Feature Control Frame

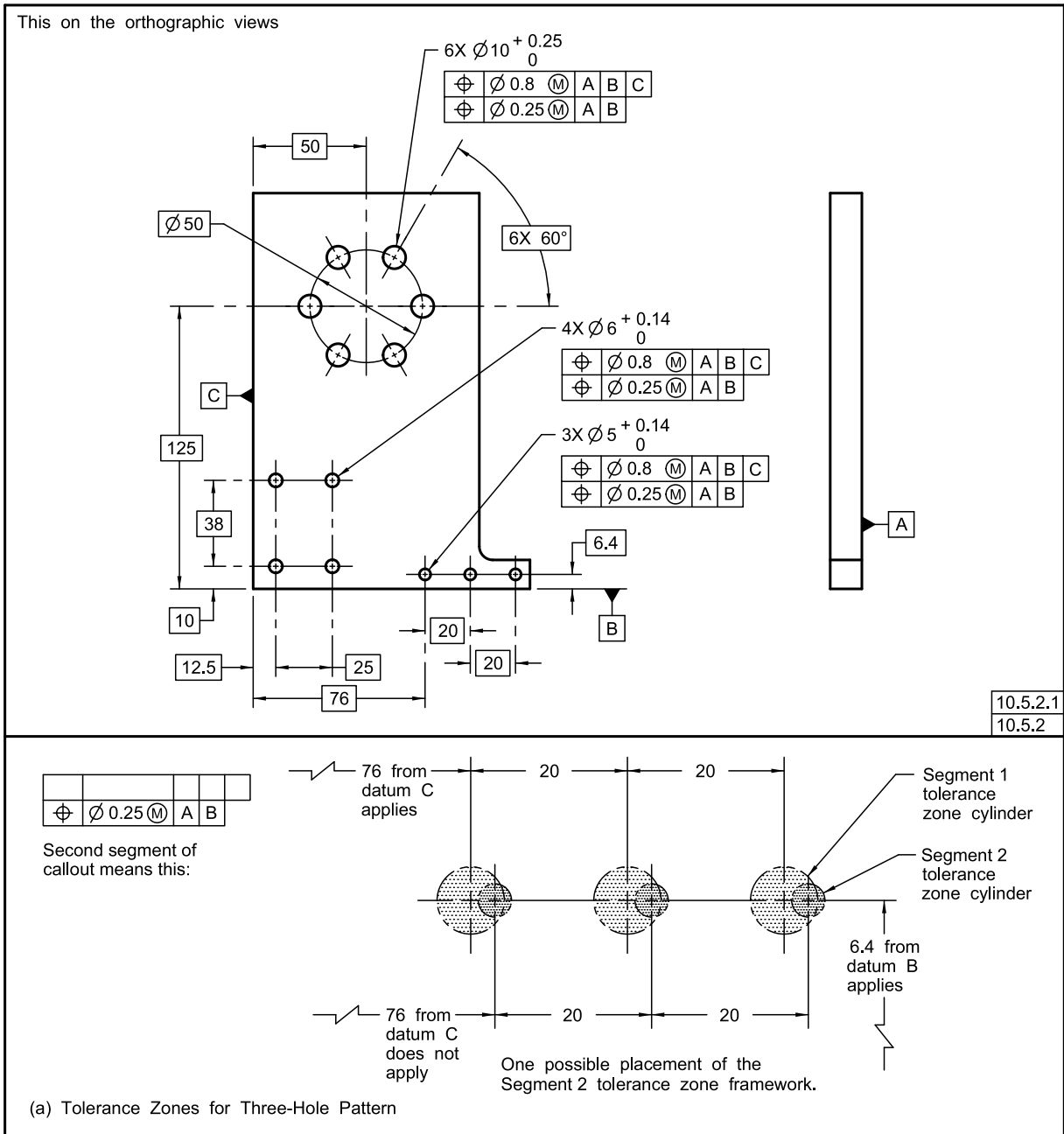

Figure 10-47 Multiple Single-Segment Feature Control Frames With Secondary Datum in Lower Feature Control Frame (Cont'd)

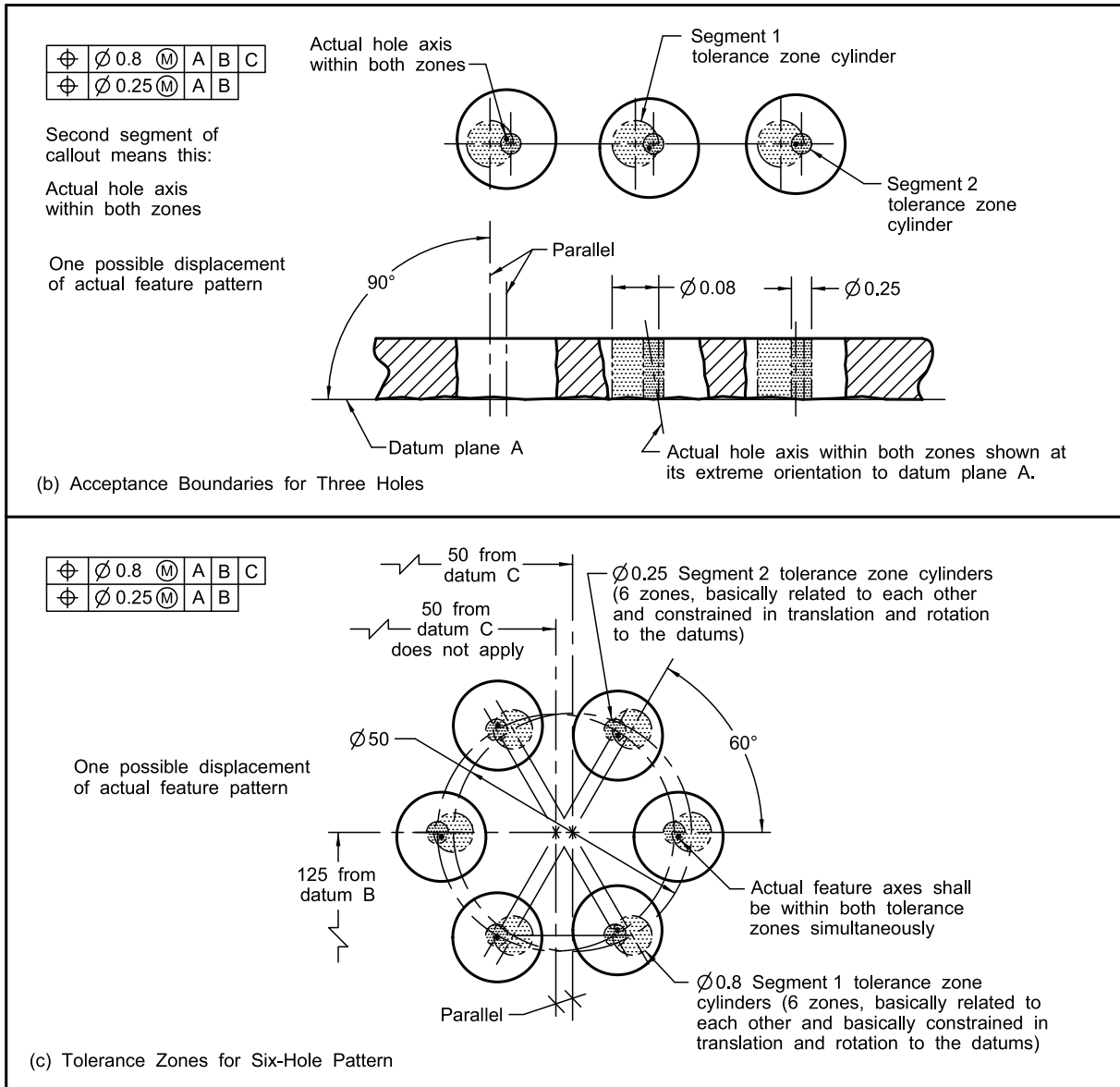

Figure 10-48 Positional Tolerancing With Multiple Single-Segment Feature Control Frames

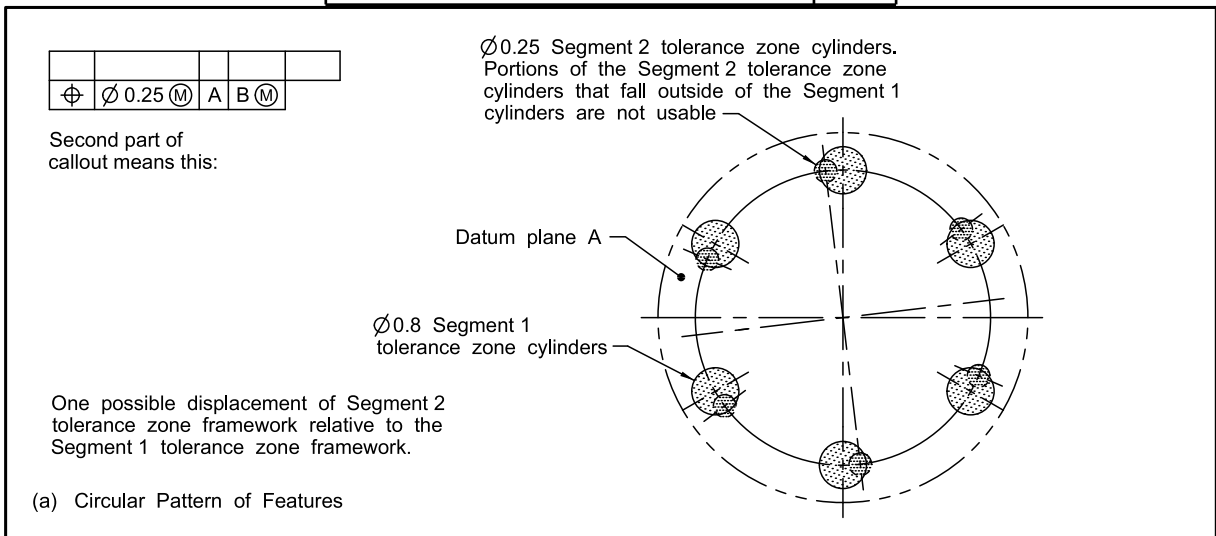
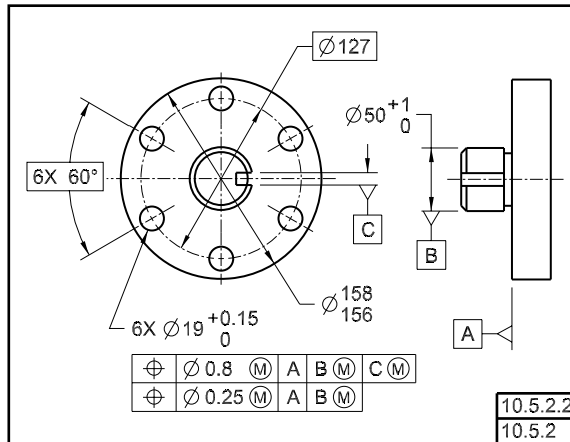

Figure 10-49 Radial Hole Pattern Located by Multiple Single-Segment Feature Control Frames

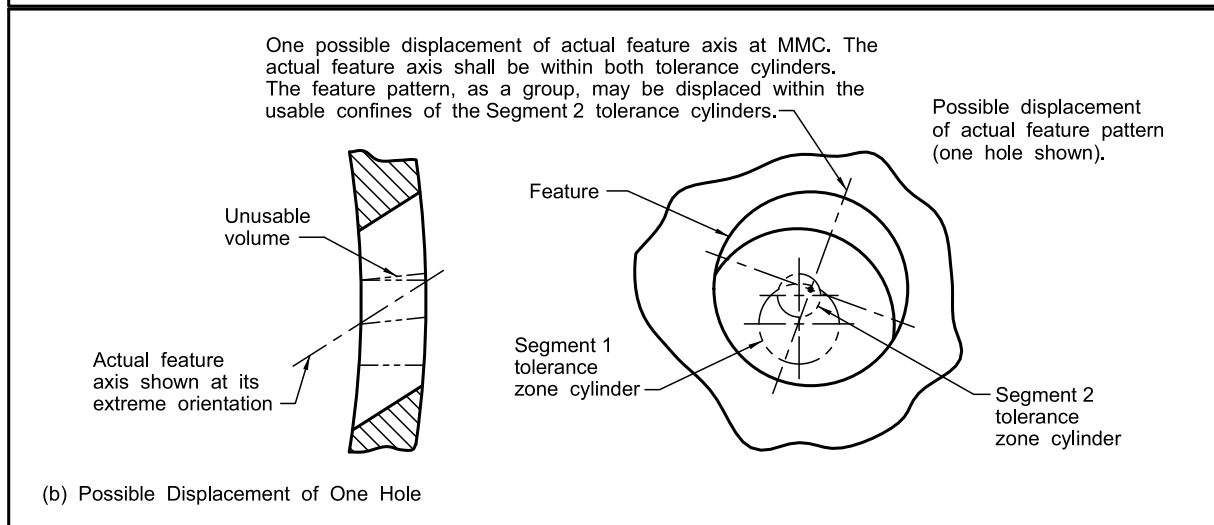
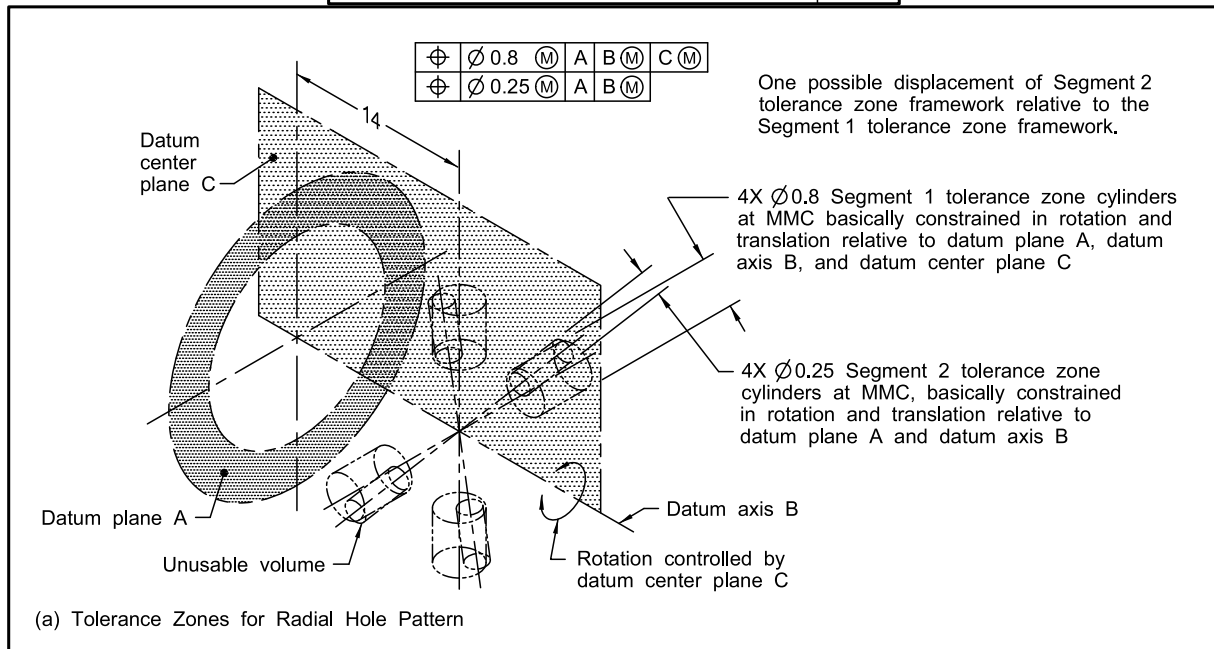
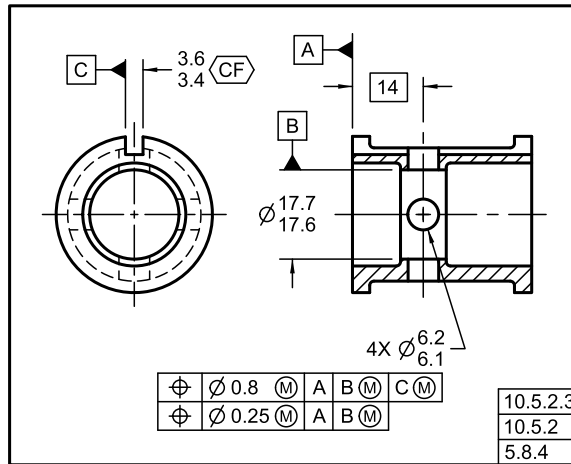

Figure 10-50 Positional Tolerancing for Coaxial Holes of Same Size

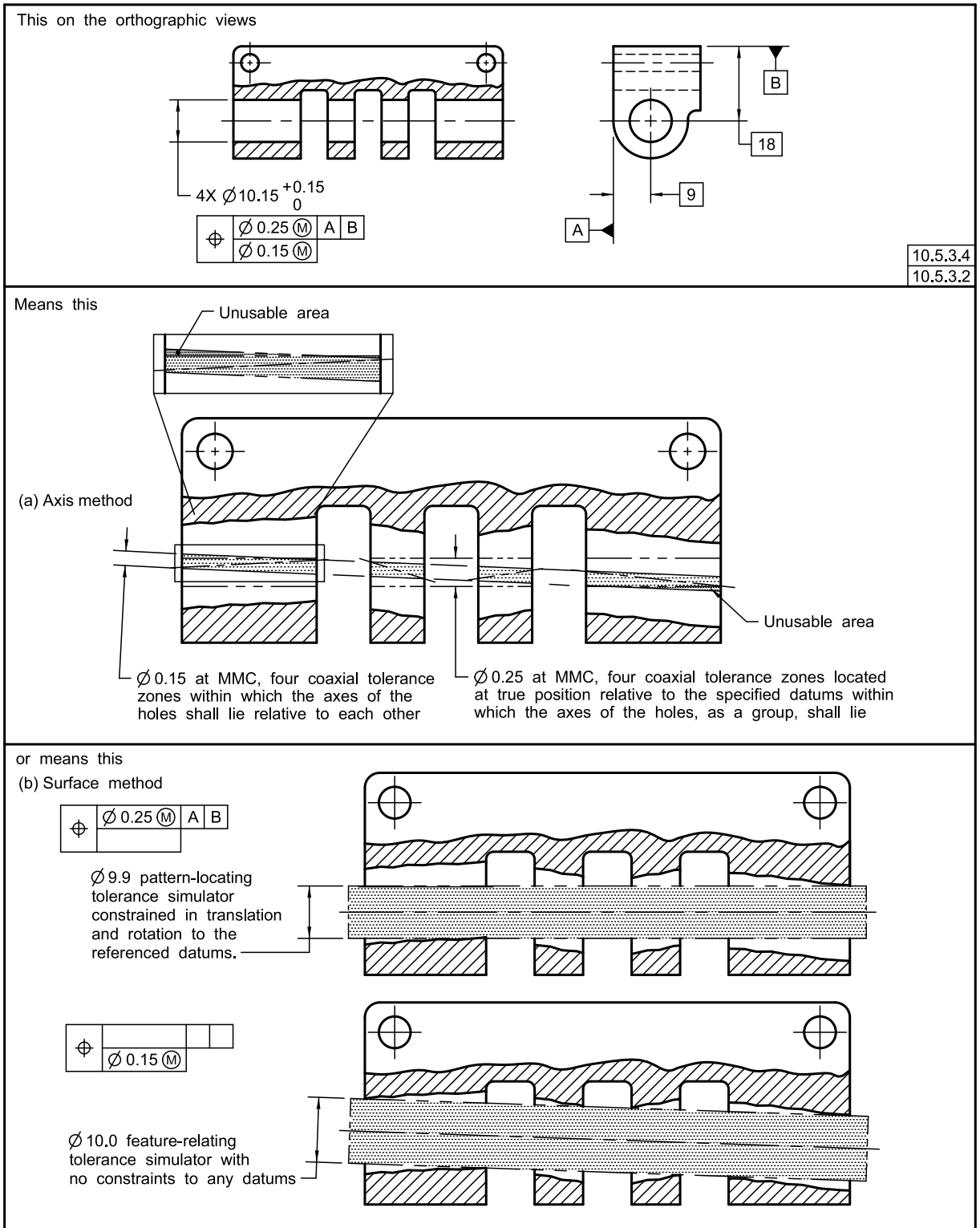

Figure 10-51 Positional Tolerancing for Coaxial Holes of Same Size, Partial (Parallelism) Refinement of Feature of Feature-Relating Axis

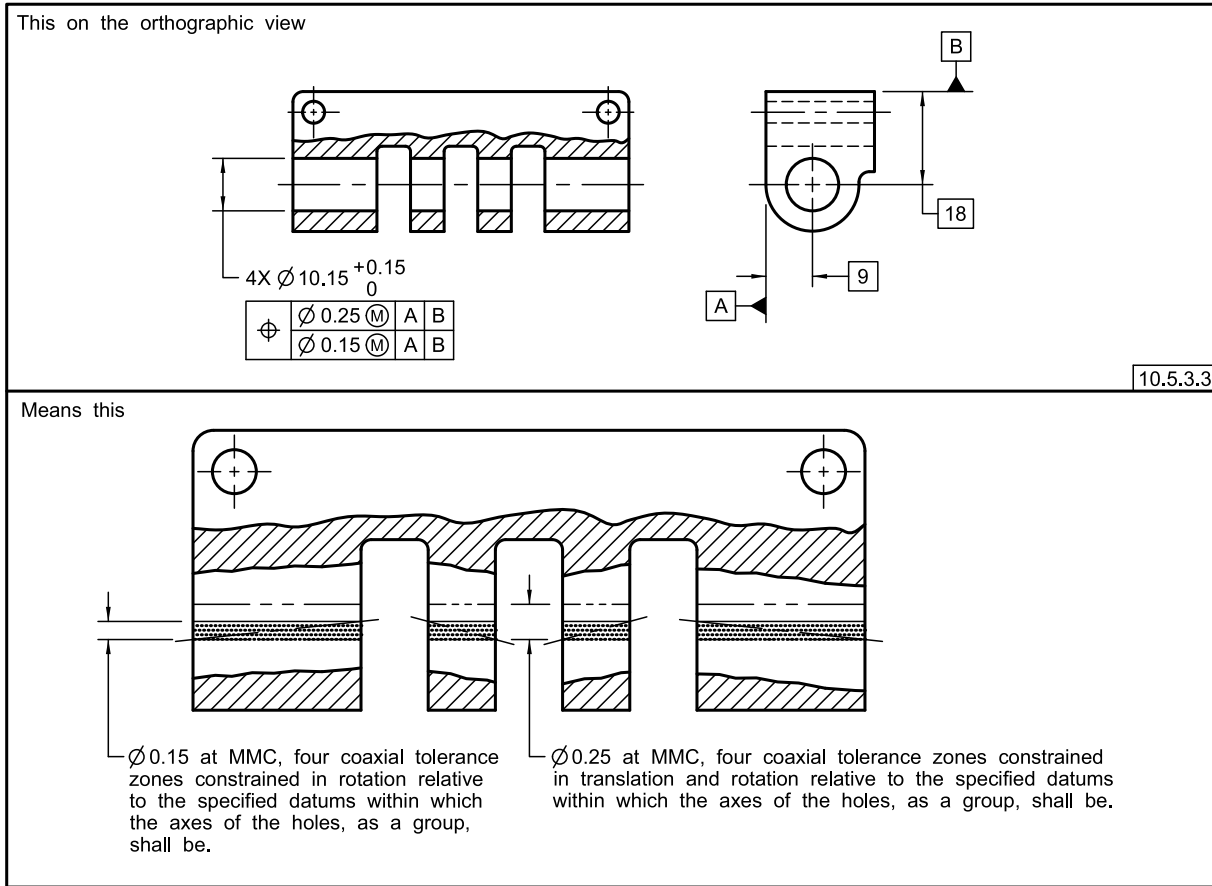

Figure 10-52 Positional Tolerancing for Multiple Features of More Than One Size

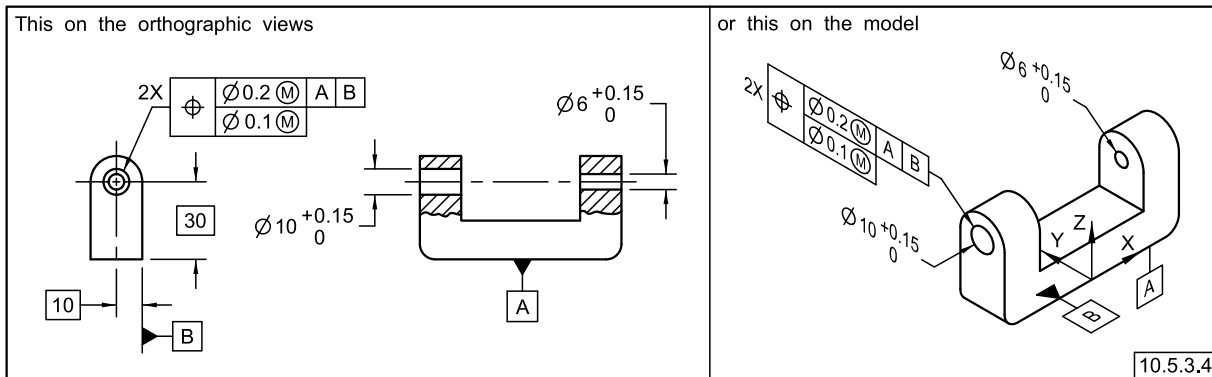

Figure 10-53 Multiple Patterns of Features, Simultaneous Requirement

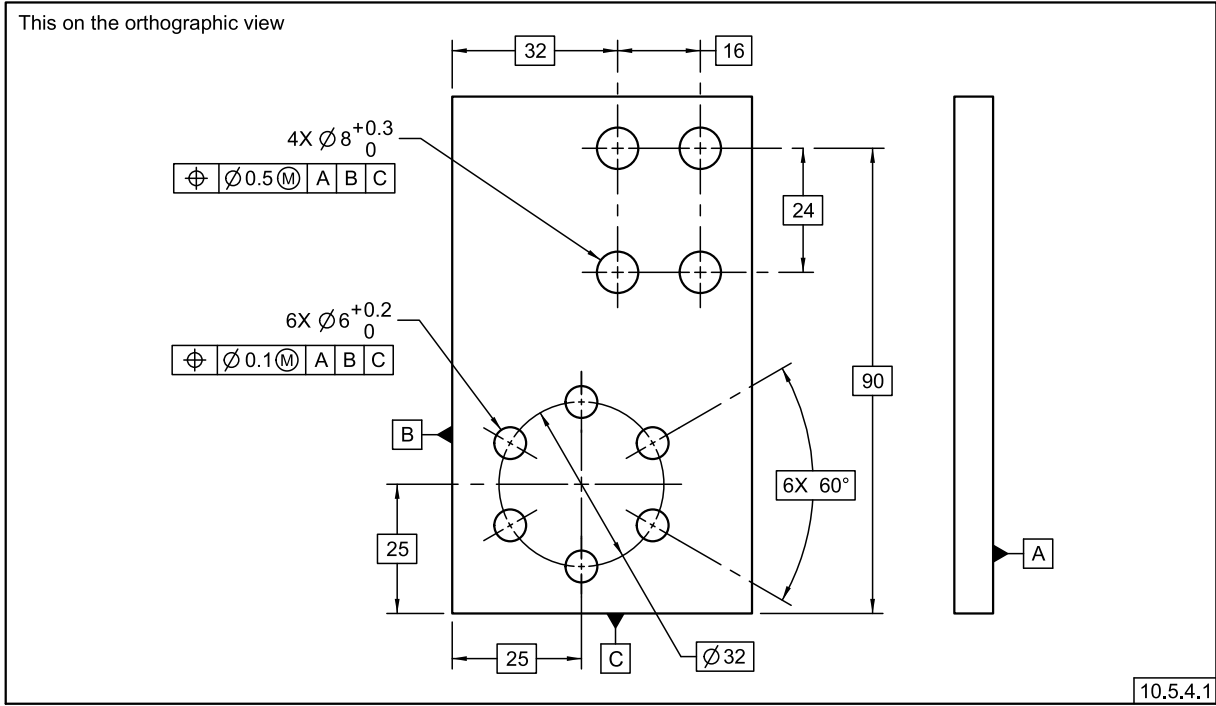

Figure 10-53 Multiple Patterns of Features, Simultaneous Requirement (Cont'd)

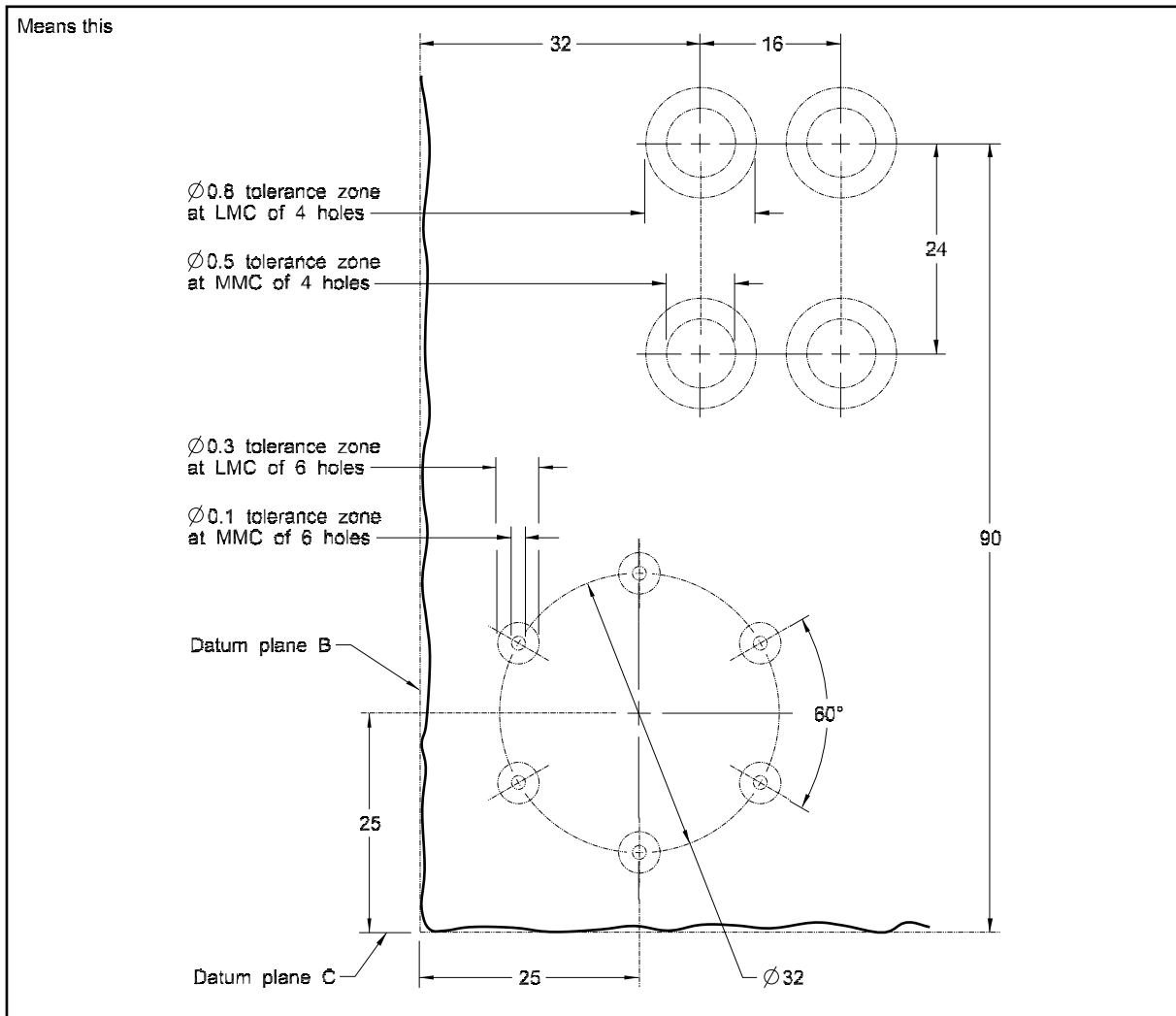

Figure 10-54 Multiple Patterns of Features, Separate Requirements

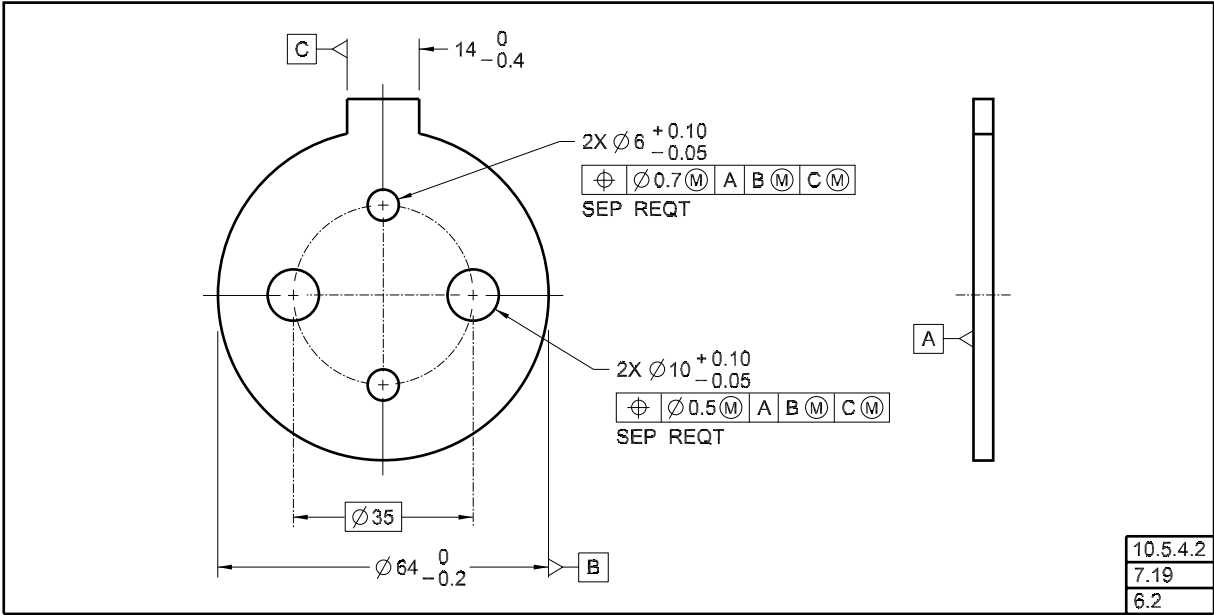
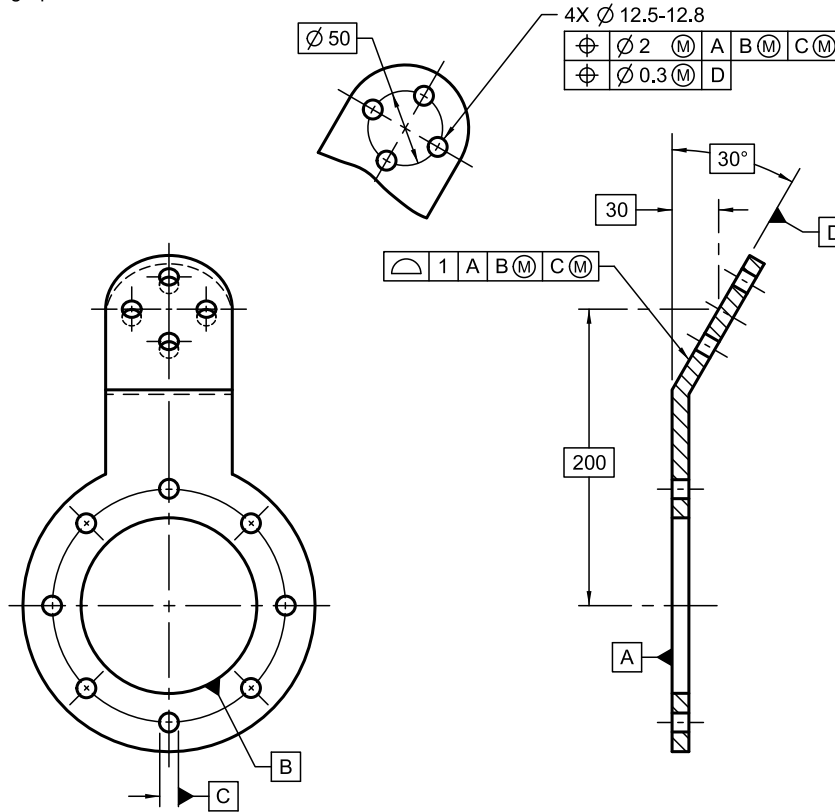

Figure 10-55 Multiple Positional Tolerancing for a Pattern of Features

This on the orthographic view



11.5
10.5.5

Means this

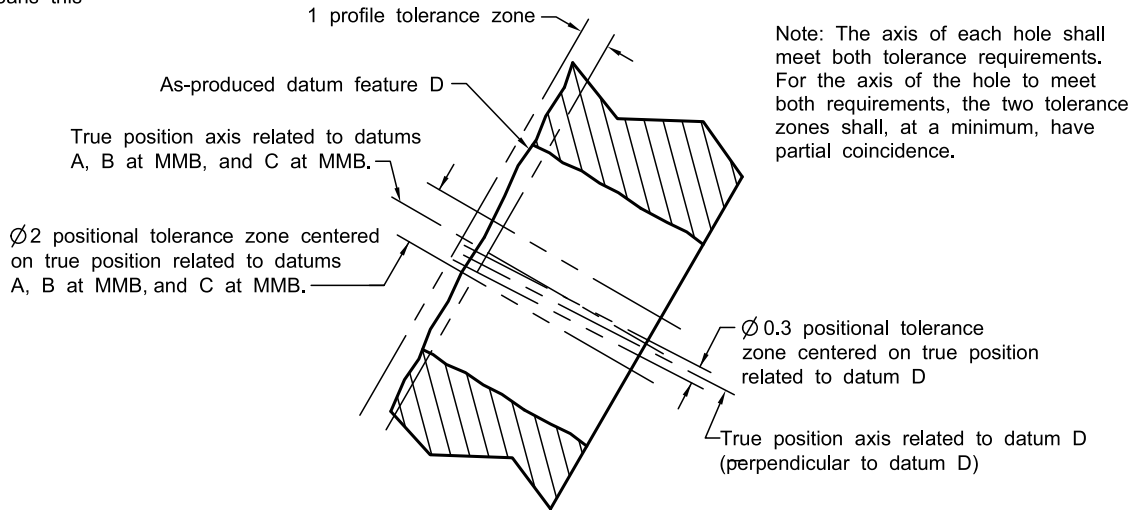

Figure 10-56 Positional Tolerancing for Coaxiality

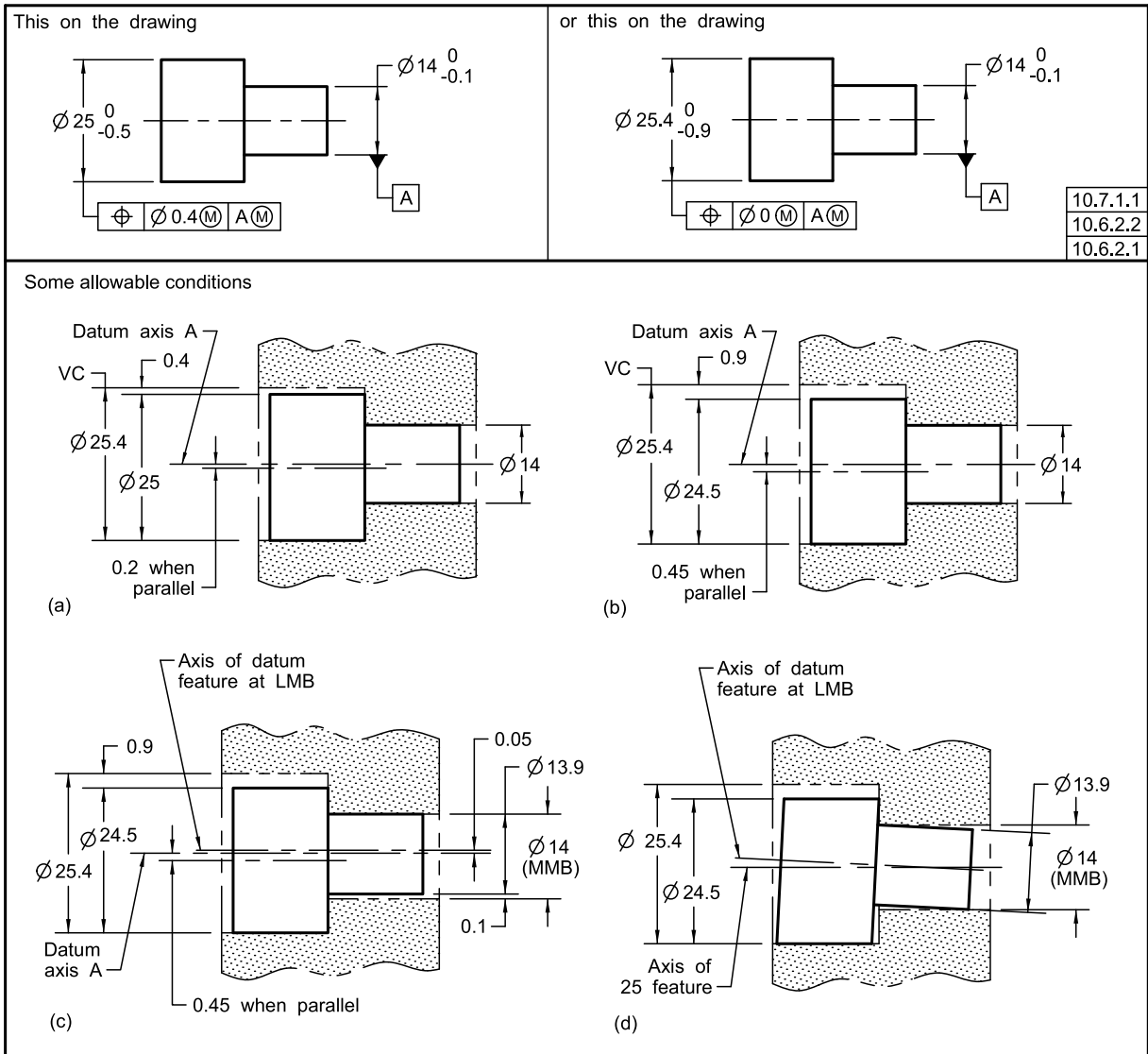

Figure 10-57 Feature Controlled With Positional Tolerance RFS and Datum Referenced RMB for Coaxiality

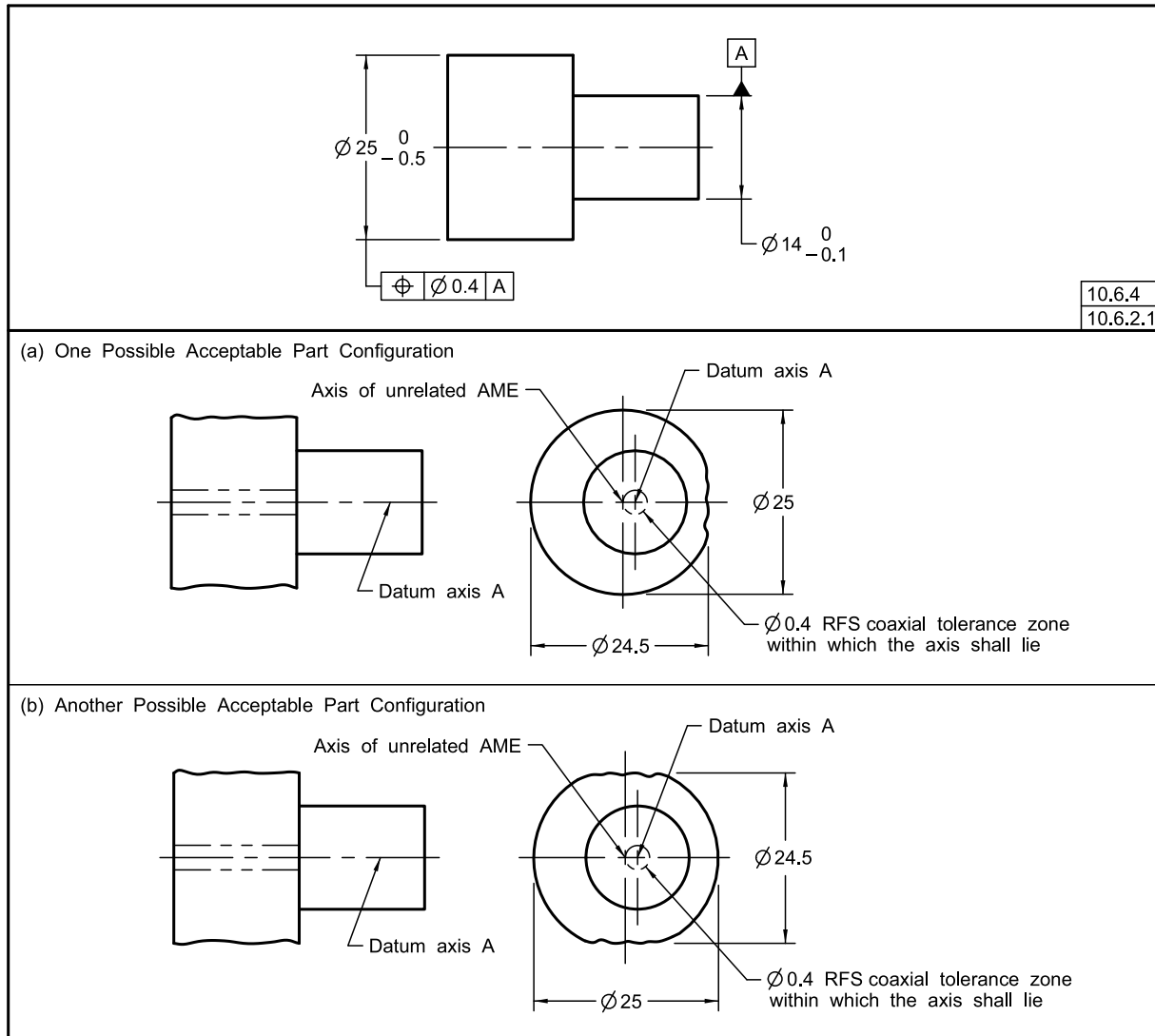

Figure 10-58 Two Datum Features, Single Datum Axis

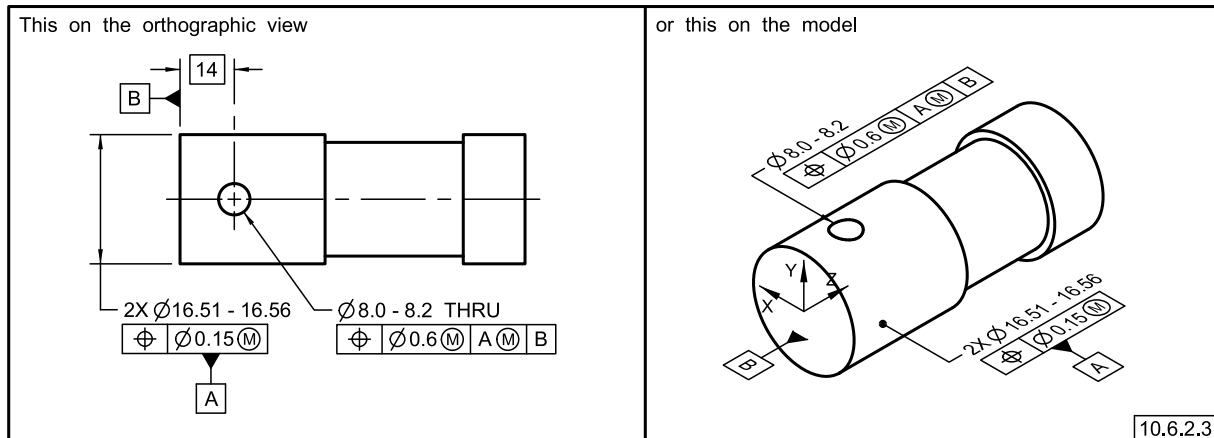
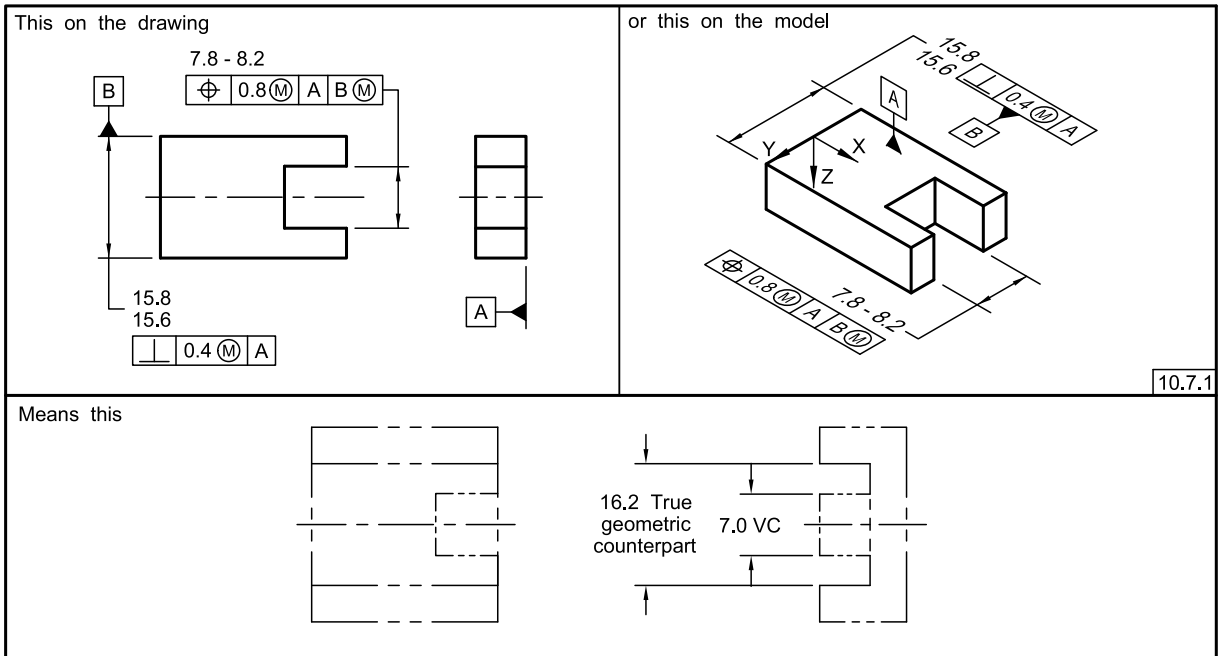
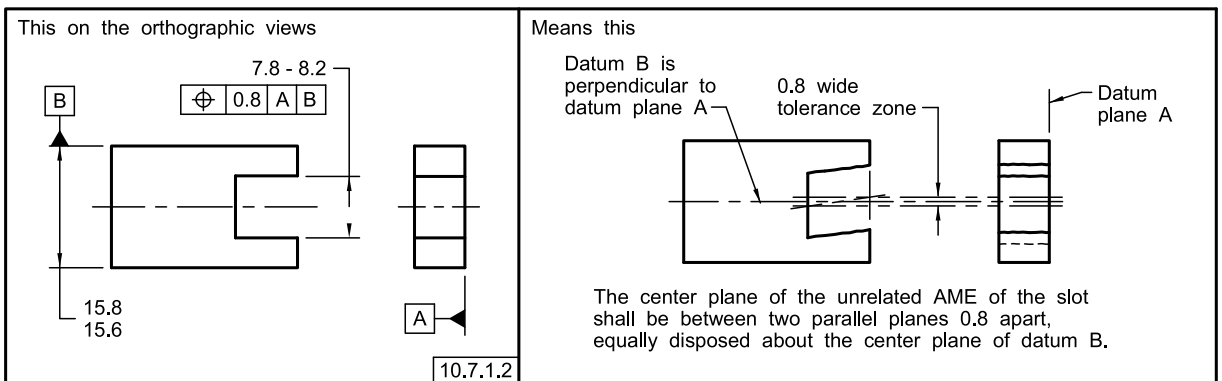

Figure 10-59 Positional Tolerancing at MMC for Symmetrical Features



10.7.1

Figure 10-60 Positional Tolerancing RFS for Symmetrical Features



10.7.1.2

Section 11

Tolerances of Profile

11.1 GENERAL

This Section establishes the principles and methods of dimensioning and tolerancing to control the profile of various features.

11.2 PROFILE

Profile tolerances are used to define a tolerance zone to control form or combinations of size, form, orientation, and location of a feature(s) relative to a true profile. Depending on the design requirements, profile tolerance zones may or may not be related to datums. A digital data file or an appropriate view on a drawing shall define the true profile. When used as a refinement of a size tolerance created by toleranced dimensions, the profile tolerance shall be contained within the size limits. For more information on design models, see ASME Y14.41.

11.2.1 Types of Profile Tolerances

A profile tolerance may be applied to an entire part, multiple features, individual surfaces, or individual profiles taken at various cross sections through a part. The two types of profile tolerances, profile of a surface and profile of a line, are explained in [paras. 11.2.1.1](#) and [11.2.1.2](#), respectively.

11.2.1.1 Profile of a Surface. The tolerance zone established by the profile of a surface tolerance is three-dimensional (a volume), extending along the length and width (or circumference) of the considered feature or features. See [Figures 11-1](#) through [11-4](#). Profile of a surface may be applied to parts of any shape, including parts that have a constant cross section as in [Figure 11-6](#), parts that have a surface of revolution as in [Figure 11-19](#), and parts that have a profile tolerance applied all over as in [Figure 11-9](#). Where the extent of the application of the profile tolerance is unclear, the “between” symbol should be used.

11.2.1.2 Profile of a Line. A model or a drawing view is created to show the true profile. Profile of a line may be applied to parts of any shape, including parts that have a varying cross section, such as the tapered wing of an aircraft, or a constant cross section, such as an extrusion, where it is not desired to have a tolerance zone include the entire surface of the feature as a single entity. See [Figures 11-31](#) and [11-32](#).

11.2.2 Profile Specification

The profile tolerance zone specifies a uniform or nonuniform tolerance boundary along the true profile within which the surface or single elements of the surface shall lie.

11.2.3 Profile Tolerances as General Requirements

When the profile tolerance feature control frame is placed in a general note or the general tolerance block, the tolerance applies to all features UOS.

11.3 TOLERANCE ZONE BOUNDARIES

Uniform, bilateral, unequally disposed, or nonuniform tolerance zones can be applied to profile tolerances. UOS, profile tolerance zones are uniform and centered on the true profile. The actual surface or line element shall be within the specified tolerance zone. Since the surface may lie anywhere within the profile boundary, the actual part contour could have abrupt surface variations. If this is undesirable, the drawing shall indicate the design requirements, such as rate of change and/or blend requirements. When a profile tolerance encompasses a sharp corner, the tolerance zone extends to the intersection of the boundary lines. See [Figure 11-5](#). Since the intersecting surfaces may lie anywhere within the converging zone, the actual part contour could be rounded. If this is undesirable, the drawing shall indicate the design requirements, such as by specifying the maximum radius.

11.3.1 Uniform Tolerance Zone

Profile tolerances apply normal (perpendicular) to the true profile at all points along the profile. The boundaries of the tolerance zone follow the geometric shape of the true profile. See [Figure 11-6](#).

11.3.1.1 Bilateral Profile Tolerance Zone. The tolerance zone may be divided bilaterally to both sides of the true profile. When an equally disposed bilateral tolerance is intended, it is necessary to show the feature control frame with a leader directed to the surface or an extension line of the surface, but not to the basic dimension. See [Figures 11-1](#) and [11-7](#).

11.3.1.2 Unilateral and Unequally Disposed Profile Tolerance. Unilateral and unequally disposed profile tolerances are indicated with an “unequally disposed”

profile symbol placed in the feature control frame. See [Figures 11-2 through 11-4](#). The “unequally disposed” symbol is placed in the feature control frame following the tolerance value. A second value is added following the “unequally disposed” symbol to indicate the tolerance in the direction that would allow additional material to be added to the true profile.

(a) *Unilateral Tolerance in the Direction That Adds Material.* When a unilateral profile tolerance is 0.3 and applies from the true profile in the direction that adds material, the tolerance value would be 0.3 and the value following the “unequally disposed” symbol would be “0.3.” See [Figure 11-3](#).

(b) *Unilateral Tolerance in the Direction That Removes Material.* When a unilateral profile tolerance is 0.3 and applies from the true profile in the direction that removes material, the feature control frame would read “0.3,” “unequally disposed” symbol, “0.” See [Figure 11-2](#).

(c) *Unequally Disposed Tolerance.* When an unequally disposed profile tolerance is 0.3 and 0.1 applies from the true profile in the direction that adds material and 0.2 applies from the true profile in the direction that removes material, the feature control frame would read “0.3,” “unequally disposed” symbol, “0.1.” See [Figure 11-4](#).

11.3.1.3 All Around Specification. When a profile tolerance applies all around the true profile of the designated features of the part (in the view in which it is specified), the “all around” symbol is placed on the leader from the feature control frame. See [Figure 11-6](#). The “all around” symbol shall not be applied in an axonometric view on a two-dimensional drawing. When the requirement is that the tolerance applies all over a part, the “all over” symbol may be used. See [para. 11.3.1.5](#).

11.3.1.4 Defining the Extent of a Profile Tolerance. When portions of a surface or surfaces have different profile tolerances, the extent of each profile tolerance shall be indicated, e.g., by the use of reference letters to identify the extremities or limits of application for each requirement accompanied with the use of the “between” symbol with each profile tolerance. See [Figure 11-8](#). Similarly, if some areas of the profile are controlled by a profile tolerance and other segments by directly toleranced dimensions, the extent of the profile tolerance shall be indicated. See [Figure 11-9](#).

11.3.1.5 All Over Specification. A profile tolerance may be applied all over the three-dimensional profile of a part UOS. It shall be applied in one of the following ways:

(a) place the “all over” symbol on the leader from the feature control frame as shown in [Figure 11-10](#)

(b) place the term “ALL OVER” beneath the feature control frame

(c) place the profile tolerance requirement in the general tolerance block or general notes

11.3.2 Nonuniform Tolerance Zone

A nonuniform tolerance zone may be indicated by stating the beginning and ending widths of a profile tolerance zone. The profile tolerance width is a proportional variation from one value to another between two specified locations on the considered feature. The values are related to the specified locations on the considered feature by the letters separated by an arrow (e.g., in [Figure 11-11](#), the value of the tolerance is 0.1 at location S and 0.3 at location T). The term “NONUNIFORM” replaces the tolerance value within the feature control frame when the profile boundaries are established by model data. See [Figures 11-11 through 11-14](#).

11.3.2.1 Drawing Indication. For the nonuniform tolerance zone, the leader line from the feature control frame is directed to the true profile. See [Figures 11-11 through 11-13](#). When individual segments of a profile are toleranced, the extent of each profile segment shall be indicated, e.g., by use of reference letters to identify the extremities or limits of each segment. See [Figures 11-12 and 11-13](#).

11.3.2.2 Zones to Smooth the Transitions. [Figure 11-8](#) illustrates abrupt transitions that occur at the transition points B and C when different profile tolerances are specified on adjoining segments of a feature. A nonuniform profile tolerance zone may be used to smooth the transition areas. See [Figure 11-14](#).

11.3.2.3 Alternative Practice. The boundaries of a “NONUNIFORM” profile tolerance may be defined by basic dimensions on a drawing with phantom lines to indicate the tolerance zone.

11.4 PROFILE APPLICATIONS

Applications of profile tolerancing are described in [paras. 11.4.1 through 11.4.4](#).

11.4.1 Profile Tolerance for Plane Surfaces

Profile tolerancing may be used to control the form, orientation, and location of plane surfaces. In [Figure 11-15](#), profile of a surface is used to control a plane surface inclined to two datum features. In this example, the tolerance zone is constrained in all three translational degrees of freedom and two rotational degrees of freedom relative to the referenced datum features.

11.4.1.1 Coplanarity. A profile of a surface tolerance may be used to control the mutual orientation and location of two or more surfaces. For basic surfaces that are coplanar (parallel with zero offset), a control is provided similar to that achieved by a flatness tolerance applied to a single plane surface. As shown in [Figure 11-16](#), the profile of a surface tolerance establishes two tolerance zones, parallel with zero offset, within which the considered surfaces shall lie. As in the case of flatness, no datum

reference is stated. When two or more surfaces are involved, it may be desirable to identify which specific surface(s) are to be used as the datum feature(s). Datum feature symbols are applied to these surfaces with the appropriate tolerance for their relationship to each other. The datum reference letters are added to the feature control frame for the features being controlled. See [Figure 11-17](#).

11.4.1.2 Offset Surfaces. A profile of a surface tolerance should be used when it is desired to control two or more surfaces offset to each other. The feature control frame is associated with the applicable surfaces. The desired offset is defined by a basic dimension. See [Figure 11-18](#).

11.4.2 Conical Surfaces

A profile tolerance should be specified to control a conical surface in one of the following ways:

(a) as an independent control of form, as in [Figure 11-19](#)

(b) as combinations of size, form, orientation, and location, as in [Figure 11-20](#)

[Figure 11-19](#) depicts a conical feature controlled by a composite profile of a surface tolerance where form of the surface is a refinement of size. In [Figure 11-20](#), the same control is applied but it is referenced to a datum axis. In each case, the feature shall be within size limits and the tolerance zone constrained in translation and rotation to the referenced datum feature.

11.4.3 Profile on Nonsize Datum Features

When the toleranced feature is or includes the referenced datum feature, the profile tolerance is affected as described in [paras. 11.4.3.1](#) and [11.4.3.2](#).

11.4.3.1 When the Toleranced Feature Is a Nonsize Datum Feature. At the datum feature, the distance to the true profile is zero. Since the datum feature may not pass through the datum plane, the tolerance on the considered feature shall be as follows:

(a) For an equal bilateral profile tolerance, half of the profile tolerance is available for variation of the datum feature. See [Figure 11-21](#).

(b) For a unilateral profile tolerance, the tolerance may only be applied into the material of the feature.

11.4.3.2 When the Toleranced Feature Includes Datum Targets. At the datum target, the contact point(s) and the true profile are coincident. The entire profile tolerance is available to the feature except at the datum target contact points. See [Figure 11-22](#).

11.4.4 Application on Continuous Features

Profile tolerances may be applied with the “CF” symbol to indicate that an interrupted surface is contained within one tolerance zone as if the features create a continuous feature. See [Figure 11-23](#).

11.5 MATERIAL CONDITION AND BOUNDARY CONDITION MODIFIERS AS RELATED TO PROFILE CONTROLS

Since profile control is used primarily as a surface control, MMC and LMC modifiers shall not be applied to the tolerance value. MMB and LMB applications (modifiers) are only permissible on the datum feature references. See [Figures 7-34](#) through [7-37](#), [7-46](#), and [10-55](#).

11.6 COMPOSITE PROFILE

A composite profile tolerance may be used when design requirements permit a profile-locating tolerance zone to be larger than the profile feature tolerance zone that controls other characteristics of the feature.

11.6.1 Composite Profile Tolerancing for a Single Feature

This method provides a composite application of profile tolerancing for location of a profiled feature as well as the requirement of various combinations of size, form, and orientation of the feature within the larger profile-locating tolerance zone. Requirements are annotated by the use of a composite profile feature control frame similar to that shown in [Figure 6-27](#), illustration (a). Each complete horizontal segment of a composite profile feature control frame constitutes a separately verifiable component of multiple interrelated requirements. The profile symbol is entered once and is applicable to all horizontal segments. The upper segment is referred to as the “profile-locating control.” It specifies the larger profile tolerance of the profiled feature and is constrained in translation and rotation to the referenced datum features. Applicable datums are specified in a desired order of precedence. The lower segments are referred to as “profile feature controls” and are constrained only in rotation relative to the referenced datum features. Each segment specifies a progressively smaller profile tolerance than the preceding segment.

11.6.1.1 Explanation of Composite Profile Tolerance for a Single Feature. [Figure 11-24](#) contains an irregular shaped feature with a composite profile tolerance applied. The toleranced feature is located from specified datums by basic dimensions. Datum feature references in the upper segment of a composite profile feature control frame serve to constrain translation and rotation of the profile-locating tolerance zone relative to referenced datums. See [Figure 11-24](#). Datum features referenced in the

lower segment constrain the rotation of the profile tolerance zone relative to the referenced datums. See [Figure 11-25](#). The tolerance values represent the distance between two boundaries disposed about the true profile with respect to the applicable datums. The actual surface of the controlled feature shall be within both the profile-locating tolerance zone and the profile feature tolerance zone.

11.6.1.2 Composite Profile Tolerancing for Multiple Features (Feature Pattern Location). When design requirements for a pattern of features permit a profile FRTZF to be located and oriented within limits imposed on it by a profile PLTZF, composite profile tolerancing is used.

11.6.1.3 Explanation of Composite Profile Tolerancing for Multiple Features. This paragraph provides a composite application of profile tolerancing for the location and orientation (translation and rotation) of a feature pattern (PLTZF) as well as the interrelation (size, form, orientation, and location) of profiled features within these patterns (FRTZF). Requirements are annotated by the use of a composite feature control frame. The profile symbol is entered once and is applicable to each horizontal segment. Each horizontal segment in the feature control frame should be verified separately. See [Figure 11-26](#).

(a) *PLTZF*. When composite controls are used, the uppermost segment is the profile pattern-locating control. The PLTZF is constrained in rotation and translation relative to the specified datums. The PLTZF specifies the larger profile tolerance for the location of the pattern of profiled features as a group. Applicable datum features are referenced in the desired order of precedence and serve to relate the PLTZF to the datum reference frame. See [Figure 11-26](#), illustration (a) and [Figure 11-27](#), illustration (a).

(b) *FRTZF*. Each of the lower segments is referred to as a “profile feature-relating control.” They govern the smaller tolerance for size, form, orientation, and location within the pattern of features and may include constraints on rotation of an FRTZF to specified datums. Basic location dimensions used to relate the PLTZF to specified datums are not applicable to the location of any FRTZF. The toleranced feature shall be within both the PLTZF and the FRTZF. See [Figure 11-26](#), illustration (b) and [Figure 11-27](#), illustration (b). In some instances, portions of the FRTZF may lie outside of the PLTZF and are not usable.

(1) When datum feature references are not specified in a lower segment of the composite feature control frame, the FRTZF is free to rotate and translate.

(2) When datum feature references are specified in a lower segment, the FRTZF is constrained only in rotation relative to the datum reference frame. See [Figure 11-26](#), illustration (c) and [Figure 11-27](#), illustration (b).

(3) When datum feature references are specified, one or more of the datum feature references specified in the upper segment of the frame are repeated, as applicable, and in the same order of precedence, to constrain rotation of the FRTZF. In some instances, the repeated datum feature references may not constrain any degrees of freedom; however, they are necessary to maintain the identical datum reference frame.

(c) Where the design requires different datums, different datum modifiers, or the same datums in a different order of precedence, multiple single-segment feature control frames shall be specified, because this constitutes multiple datum reference frames. This shall not be specified using the composite profile tolerancing method.

11.6.1.4 Primary Datum Feature Repeated in Lower Segment(s). As can be seen from the sectional view of the tolerance zones in [Figure 11-26](#), illustration (d), since datum feature A has been repeated in the lower segment of the composite feature control frame, the profile zones of both the PLTZF and the FRTZF are perpendicular to datum plane A and, therefore, parallel to each other. See also [Figure 11-26](#), illustration (c). The profile of the actual feature may vary obliquely (out of perpendicularity) only within the confines of the respective smaller feature-relating tolerance zones (FRTZF).

11.6.1.5 Primary and Secondary Datum Features Repeated in Lower Segment(s). [Figure 11-27](#) repeats the feature patterns of [Figure 11-26](#). In [Figure 11-27](#), the lower segment of the composite feature control frame repeats datum feature references A and B. [Figure 11-27](#), illustrations (a) and (b) show that the tolerance zones of the FRTZF may be translated from the true locations (as a group), as governed by the tolerance zones of the PLTZF, constrained in rotation by datum planes A and B. [Figure 11-27](#), illustration (a) shows that the actual surfaces of the features reside within both tolerance zones of the FRTZF and the PLTZF.

11.6.2 Composite Profile With Independent Size/Form Control

When the design requires that the size and form of one or more features be controlled independently of the composite profile tolerance, a separate single-segment profile feature control frame is used followed by the term “INDIVIDUALLY.” The size/form tolerance specified shall be less than the tolerance in the lower segment (FRTZF) of the composite profile control. See [Figure 11-28](#).

11.7 MULTIPLE SINGLE-SEGMENT PROFILE TOLERANCING

For multiple single-segment profile tolerancing, datum feature references are interpreted the same as for multiple single-segment positional tolerancing. See [para. 10.5.2](#).

11.8 COMBINED CONTROLS

Profile tolerancing may be combined with other types of geometric tolerancing. Profile tolerancing may be combined with positional tolerancing when it is necessary to control the boundary of a noncylindrical feature. See [Figure 11-29](#). In this example, the basic dimensions and the profile tolerance establish a tolerance zone to control the shape and size of the feature. Additionally, the positional tolerance establishes a theoretical boundary offset from the applicable profile boundary. For an internal feature, the boundary equals the MMC size of the profile minus the positional tolerance, and the entire feature surface shall lie outside the boundary. For an external feature, the boundary equals the MMC size of the profile plus the positional tolerance, and the entire feature surface shall be within the boundary. The term “BOUNDARY” is optional and may be placed beneath the positional feature control frame. [Figure 11-30](#) illustrates a surface that has a profile tolerance refined by a runout tolerance. The entire surface shall be within the profile tolerance, and the circular elements shall be within the specified runout tolerance.

11.9 PROFILE OF A LINE AS A REFINEMENT

When it is a requirement to control individual line elements of a surface, a profile of a line tolerance is specified. See [Figures 11-31](#) through [11-34](#). This permits control of individual line elements of the surface independently in relation to the datum reference frame and does not limit the total surface to an encompassing zone. [Figure 11-31](#) illustrates a surface that has a profile of a surface tolerance refined by a profile of a line tolerance. The surface shall be within the profile of a surface tolerance, and each straight line element of the surface shall also be parallel to the datum planes established by datum features A and B within the tolerance specified. A customized datum reference frame is used to release the profile of a line tolerance from the translational constraints of the datum reference frame. [Figure 11-32](#) illustrates a part with a profile of a line tolerance where size is controlled by a separate tolerance. Line elements of the surface along the profile shall be within the profile tolerance zone and within a size-limiting zone. In this application, the profile of a line is applied on one surface of a width feature of size and the datum feature references can only constrain the rotational degrees of freedom for the profile of a line tolerance. [Figure 11-33](#) illustrates the profile of a line being used

to control the perpendicularity of radial line elements in a surface. [Figure 11-34](#) illustrates the profile of a line being used to control the parallelism of radial line elements in a surface. A customized datum reference frame is used to constrain only two rotational degrees of freedom relative to the primary datum A plane and two translational degrees of freedom relative to the secondary datum axis B. The translational degree of freedom from the primary datum is not constrained.

11.10 DYNAMIC PROFILE TOLERANCE MODIFIER

By default, a profile tolerance zone follows the true profile of the considered feature. A profile tolerance zone is static and controls both the form and size of the considered feature unless the dynamic profile tolerance modifier is applied. When it is desirable to refine the form but not the size of a considered feature that is controlled by a profile tolerance, the dynamic profile tolerance modifier, Δ , may be applied to a refining profile tolerance. The function of the dynamic profile is to allow form to be controlled independent of size.

When the dynamic profile tolerance modifier is applied, the zone is permitted to progress (expand or contract normal to the true profile) while maintaining the specified constant width (distance between the boundaries). This retains the form control while relaxing the size control. The actual feature shall simultaneously be within the dynamic profile tolerance zone and any other applicable tolerance zone.

11.10.1 Dynamic Profile Tolerance Controlling Form

When the dynamic tolerance modifier is applied to a lower segment of a composite tolerance without datum feature references, the tolerance zone controls the form but not the size of the feature and it uniformly progresses (expands or contracts) normal to the true profile, UOS. See [Figure 11-35](#). The 2 profile tolerance zone is constrained in translation and rotation relative to the datum reference frame established by datum features A, B, and C. In [Figure 11-35](#), the 0.4 dynamic profile zone is an equal bilateral about the basic profile of the toleranced feature. The 0.4 dynamic profile tolerance zone may rotate and translate relative to the datum reference frame. In addition, the tolerance zone may expand or contract while maintaining the form of the feature within the 0.4 tolerance zone, releasing the size of the feature to uniformly progress within the upper segment of the composite profile tolerance. The actual feature shall simultaneously be within both tolerance zones.

11.10.2 Dynamic Profile Tolerance Controlling Form and Orientation

When the dynamic tolerance modifier is applied to a lower segment of a composite tolerance and includes datum feature references, the tolerance zone controls the form and orientation but not the size of the feature. See [Figure 11-36](#). The 2 profile tolerance zone is constrained in translation and rotation relative to the datum reference frame established by datum features A, B, and C. The 0.4 dynamic profile tolerance zone in the lower segment of the composite tolerance is constrained in rotation but not translation relative to the datum reference frame. This tolerance zone may expand or contract while maintaining the form and orientation of the feature within the 0.4 tolerance zone, allowing the size of the feature to uniformly progress. The actual feature shall simultaneously be within both tolerance zones.

11.10.3 Dynamic Profile Tolerance Applied to the Lower Segment of Multiple Single-Segment Feature Control Frames

When the dynamic profile tolerance modifier is applied in a segment of multiple single-segment feature control frames and includes datum feature references, the tolerance zone is constrained in translation and rotation, but not size, as applicable. The tolerance zone controls the form and orientation of the feature. See [Figure 11-37](#). The 2 profile tolerance zone is constrained in translation

and rotation relative to the datum reference frame established by datum features A, B, and C. The 0.4 dynamic profile tolerance zone in the lower segment is constrained in translation and rotation relative to the datum reference frame. This tolerance zone may expand or contract while controlling the form, orientation, and location of the feature within the 0.4 tolerance zone, allowing the size of the feature to uniformly progress. The actual feature shall simultaneously be within both tolerance zones.

NOTE: Multiple features are considered to be a single feature unless "INDIVIDUALLY" follows a separate single-segment profile feature control frame.

11.10.4 Dynamic Profile Tolerance Applied to a Surface of Revolution

The dynamic profile tolerance may be applied to surfaces of revolution to maintain the shape of the considered feature while allowing its size to vary. See [Figure 11-38](#). The entire surface between A and B shall be within the profile tolerance of 0.25, which is equally disposed about the true profile. The 0.15 dynamic profile tolerance zone in the lower segment is constrained in translation and rotation relative to the datum reference frame. This tolerance zone may expand or contract while controlling the form, orientation, and location of the feature within the 0.15 tolerance zone, allowing the size of the feature to uniformly progress. The actual feature shall simultaneously be within both tolerance zones.

Figure 11-1 Profile of a Surface Application (Bilateral)

This on the orthographic view

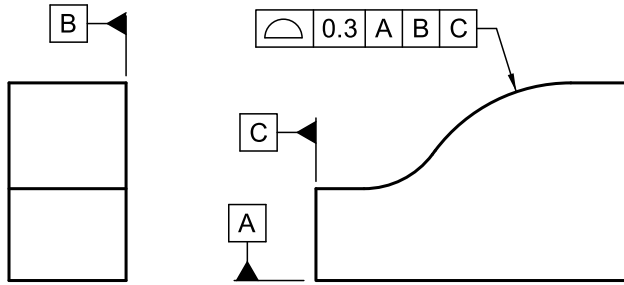

or this on the model

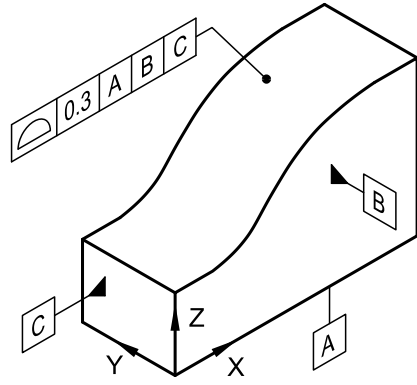

11.3.1.1
11.2.1.1

Means this

Profile of a surface tolerance applies equal bilaterally relative to the true profile when located on datum planes A, B, and C.

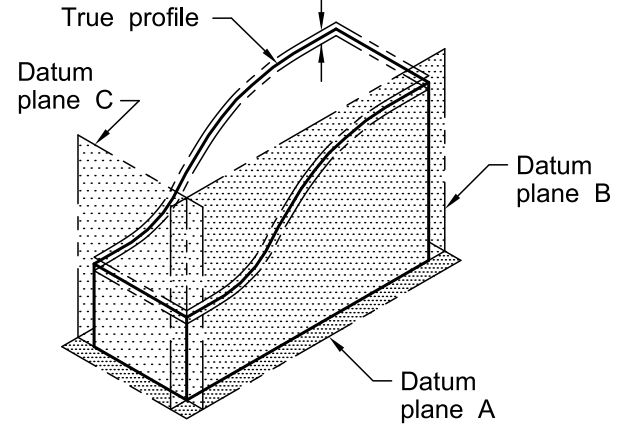
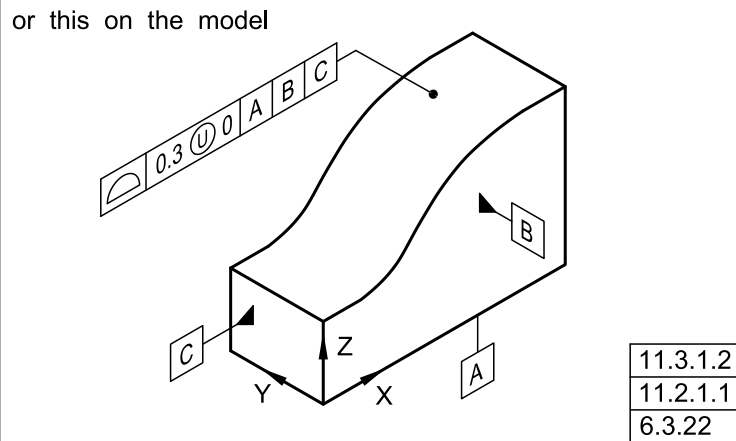
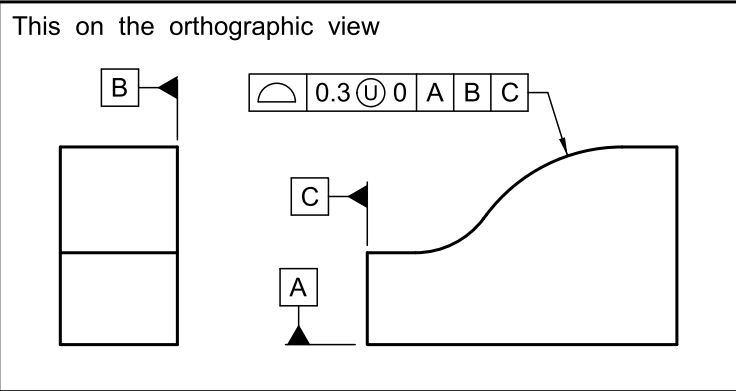

Figure 11-2 Profile of a Surface Application (Unilaterally Inside)



Means this

Profile of a surface tolerance applies unilaterally into the part when located on datum planes A, B, and C. The 0 following the "unequally disposed" symbol indicates the amount of tolerance zone adding material to the true profile.

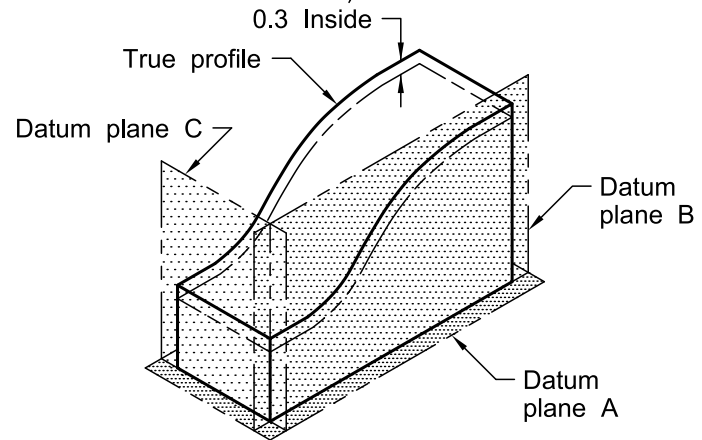
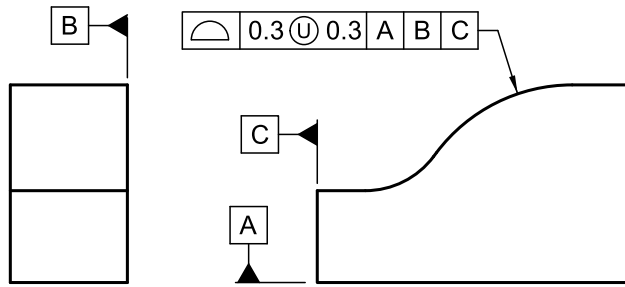
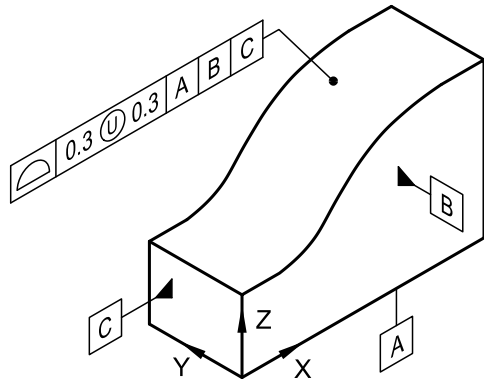

Figure 11-3 Profile of a Surface Application (Unilaterally Outside)

This on the orthographic view



or this on the model



11.3.1.2
11.2.1.1
6.3.22

Means this

Profile of a surface tolerance applies unilaterally away from the part when located on datum planes A, B, and C. The 0.3 following the "unequally disposed" symbol indicates the amount of tolerance zone adding material to the true profile.

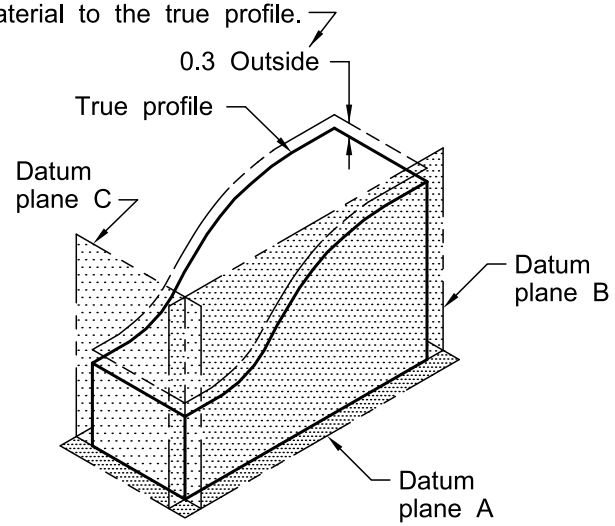
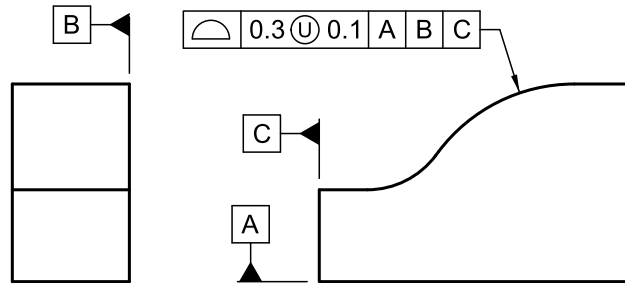
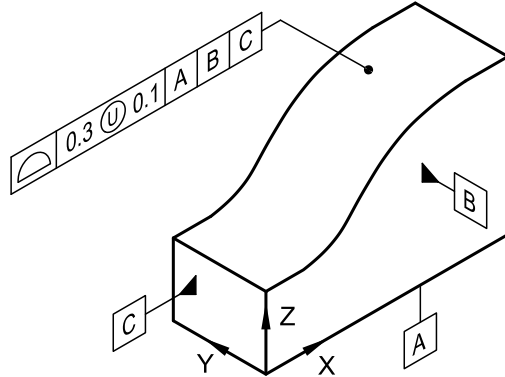

Figure 11-4 Profile of a Surface Application (Unequally Disposed)

This on the orthographic view



or this on the model



11.3.1.2
11.2.1.1
6.3.22

Means this

Profile of a surface tolerance applies unequally. The 0.1 following the "unequally disposed" symbol indicates the amount of tolerance zone adding material to the true profile.

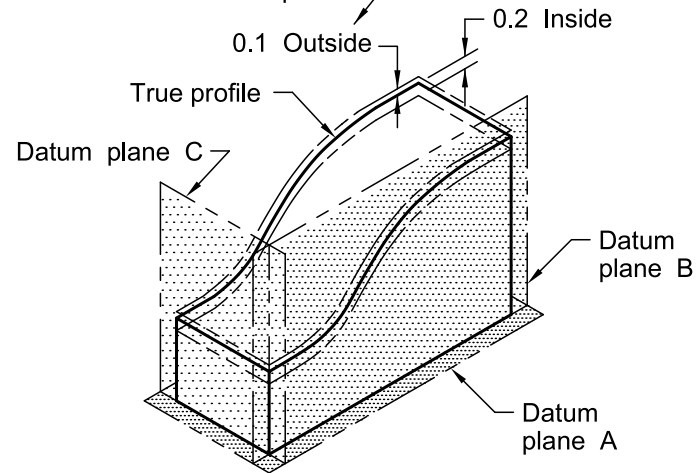
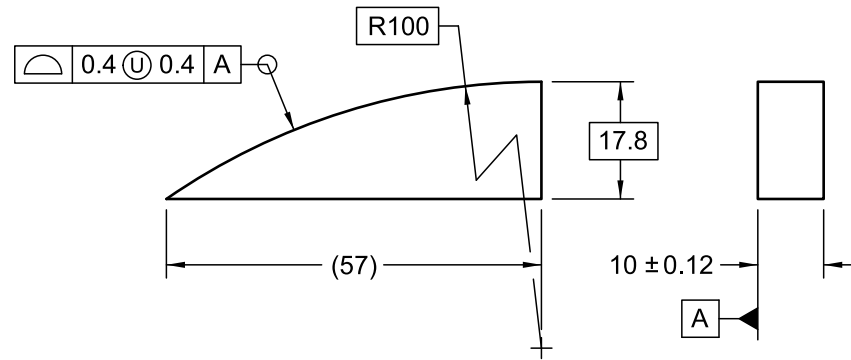

Figure 11-5 Specifying the Profile of a Surface for Sharp Corners

This on the orthographic view



11.3
6.3.19

Means this

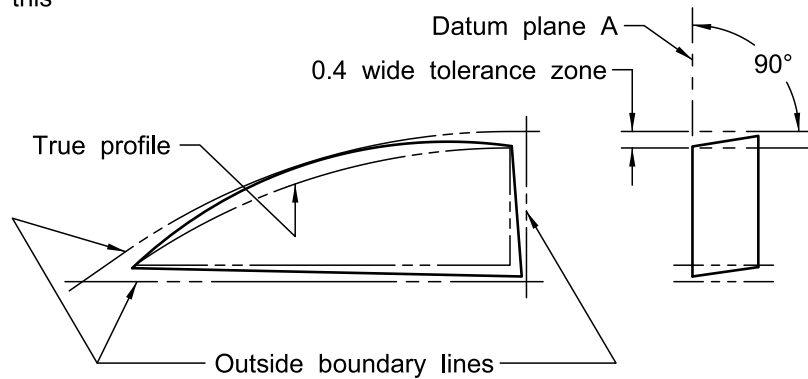

The surfaces all around shall be within two profile boundaries 0.4 apart, one coincident with and the other outside the true profile, and both perpendicular to datum plane A. The tolerance zone extends to the intersection of the boundary lines.

Figure 11-6 Specifying Profile of a Surface All Around

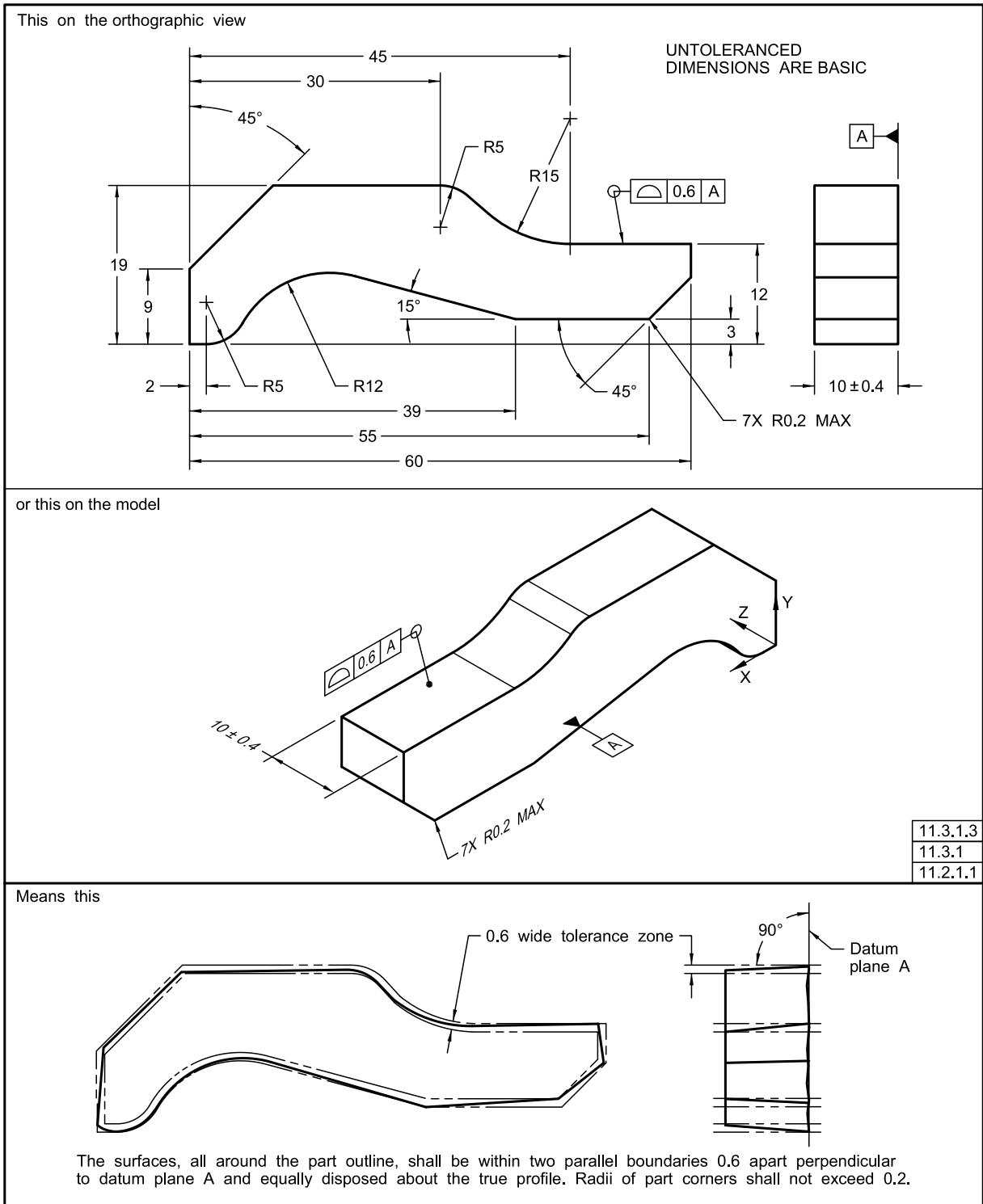
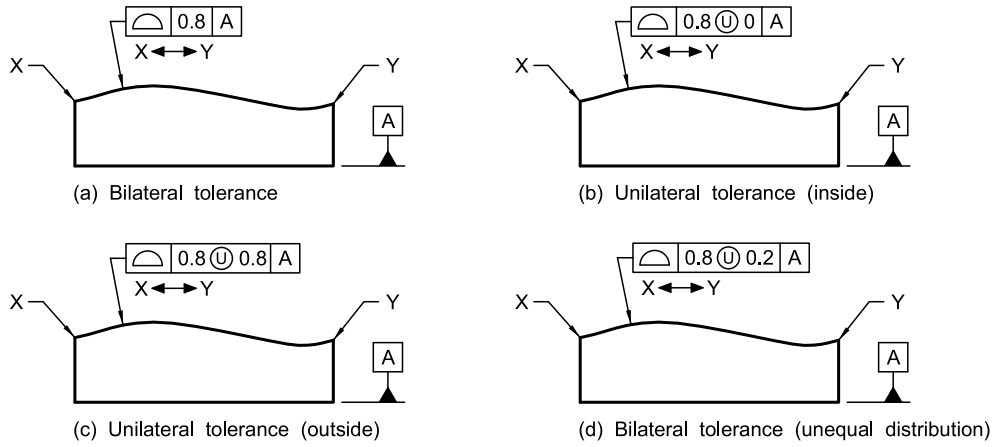

Figure 11-7 Application of Profile of a Surface Tolerance to a Basic Contour

This on the orthographic views



11.3.1.1

Means this

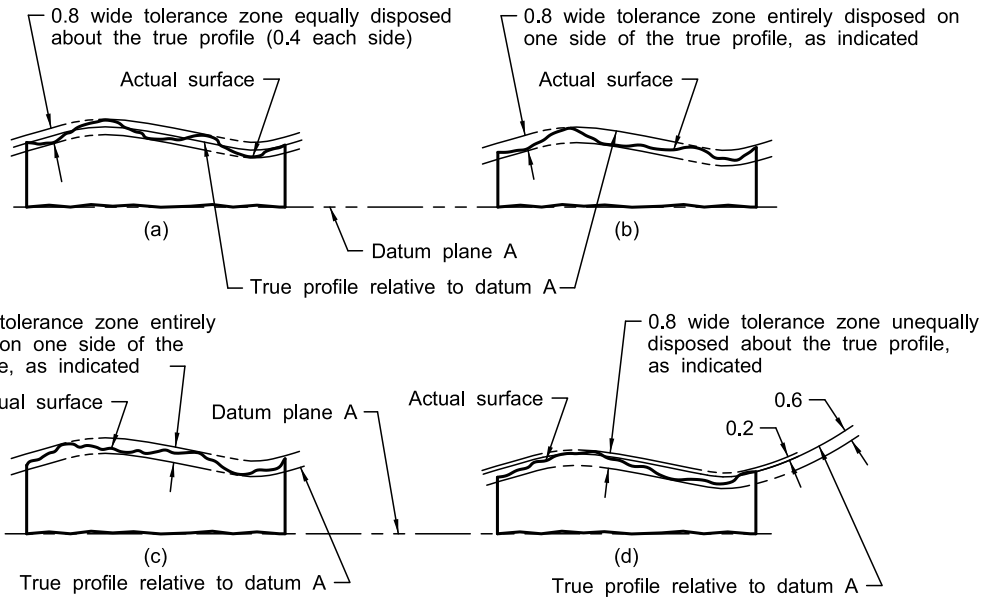

Figure 11-8 Specifying Different Profile Tolerances on Segments of a Profile

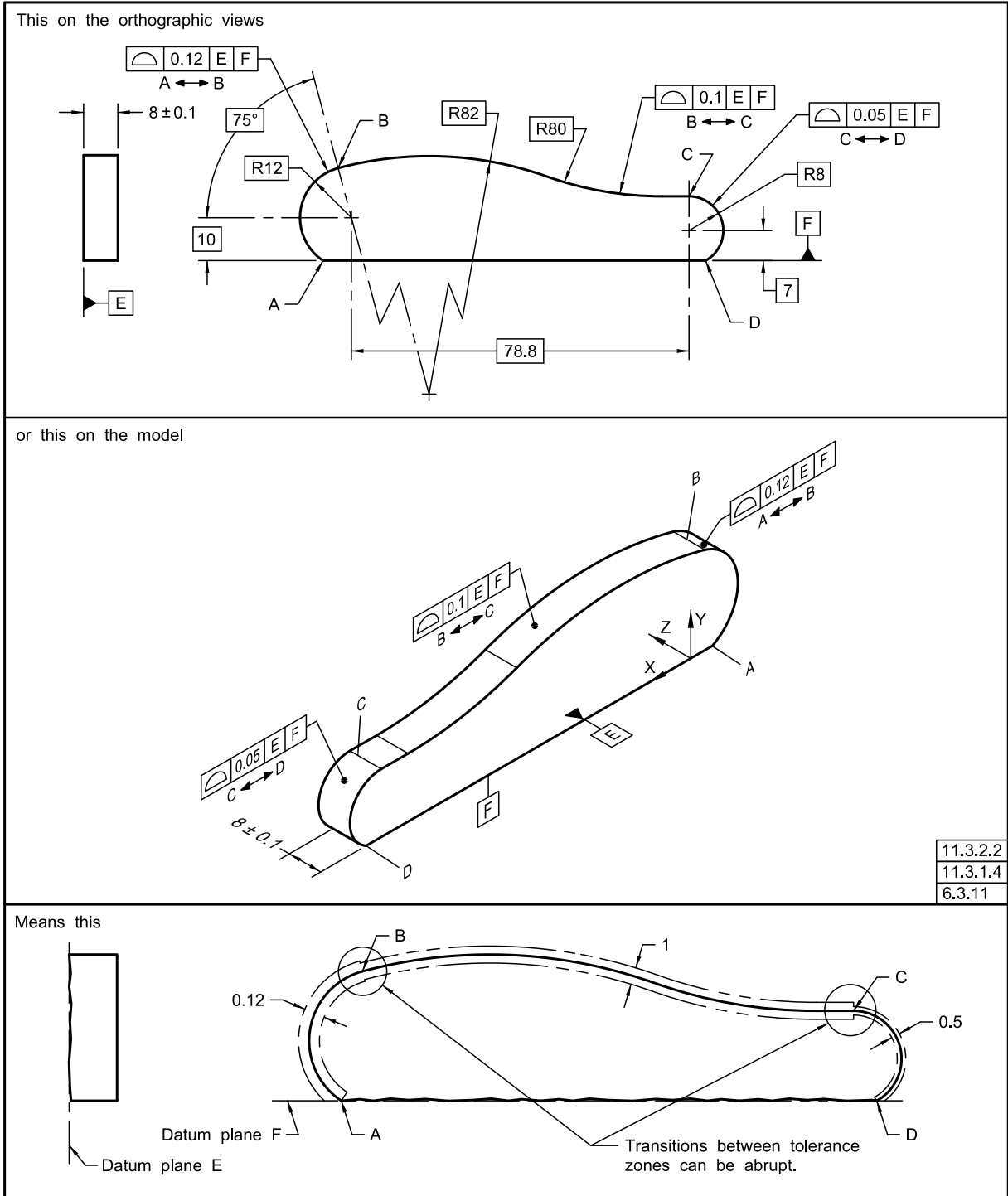
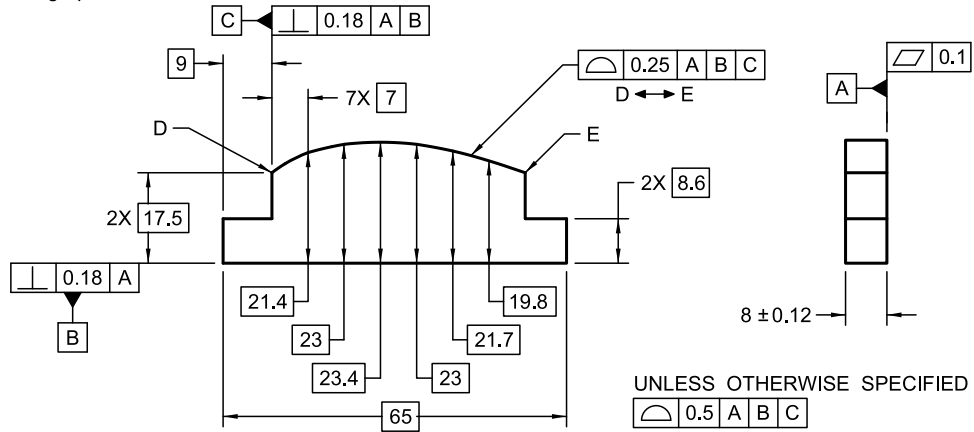
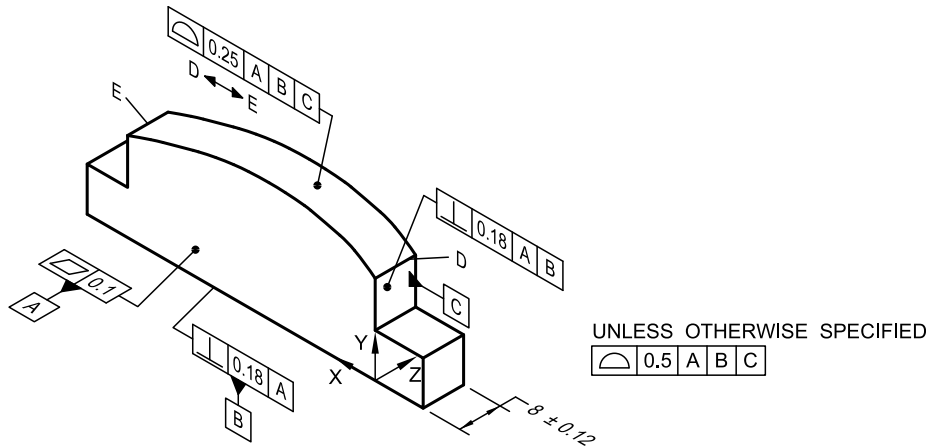

Figure 11-9 Specifying Profile of a Surface Between Points

This on the orthographic views



or this on the model



11.3.1.4
6.3.11

Means this

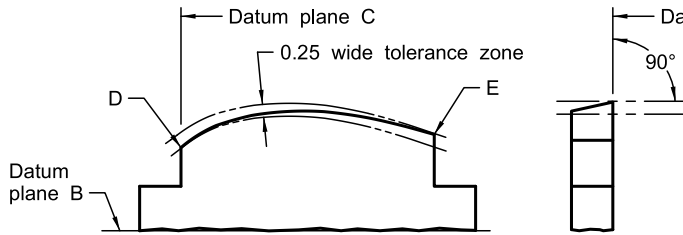

The surface between D and E shall be within two profile boundaries 0.25 apart, perpendicular to datum plane A, equally disposed about the true profile, and positioned with respect to datum planes B and C.

Figure 11-10 Specifying Profile of a Surface All Over

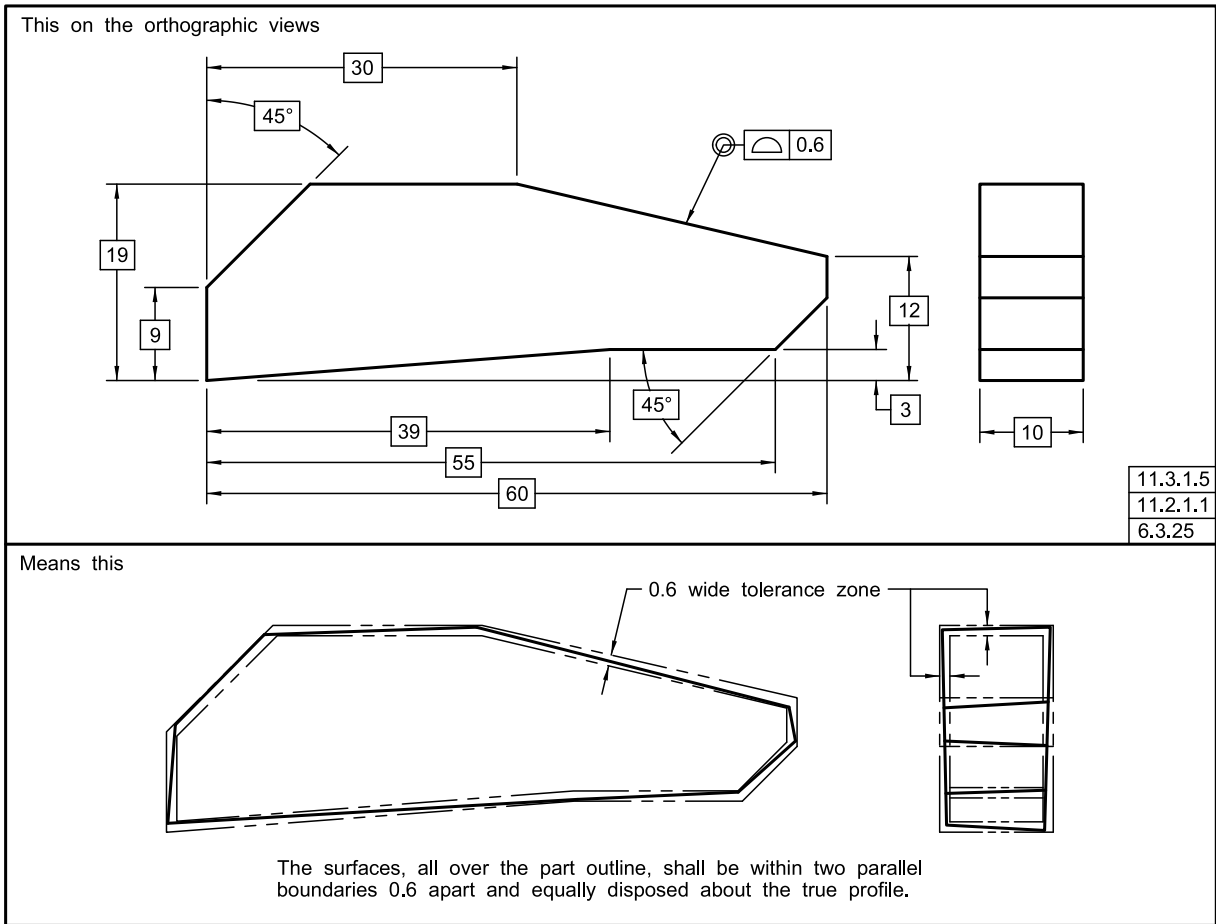

Figure 11-11 Nonuniform Profile Tolerance Zone

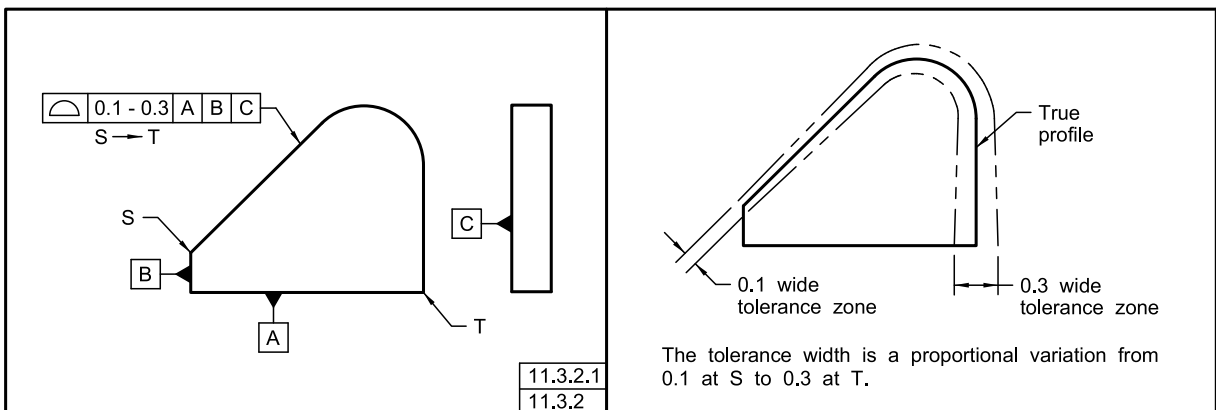

Figure 11-12 Nonuniform Profile Tolerance Zone With Multiple Segments

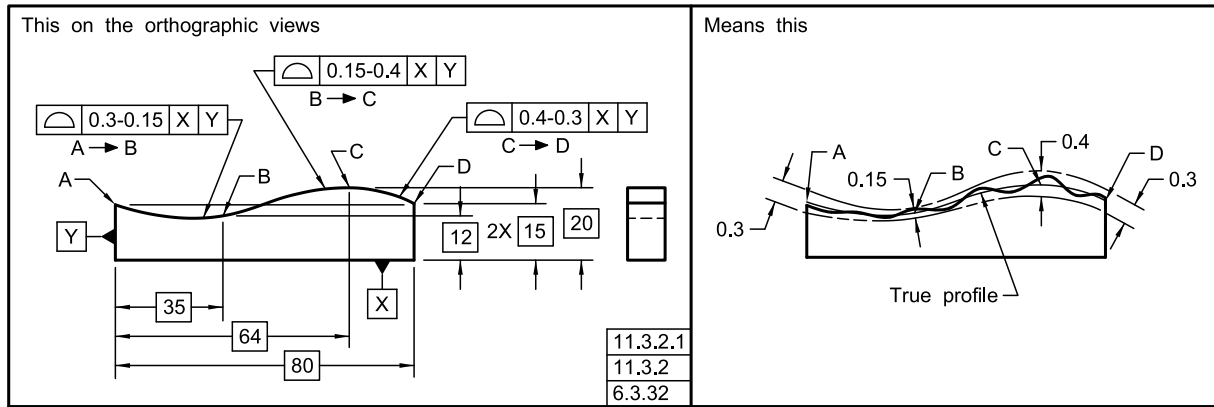

Figure 11-13 Nonuniform Profile Tolerance Zone With Zones to Smooth Transitions

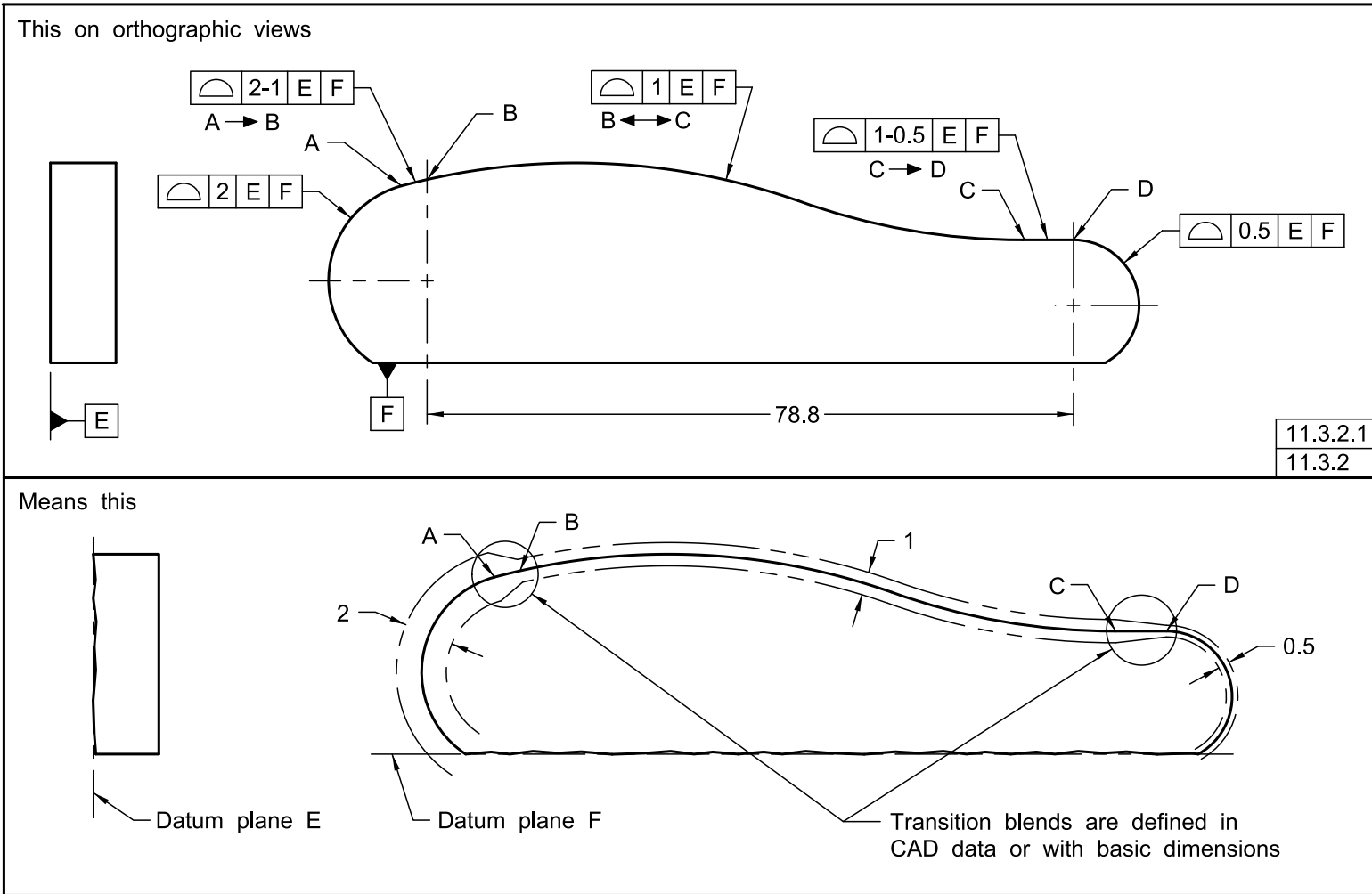

Figure 11-14 Nonuniform Profile Tolerance Zone Alternative Practice

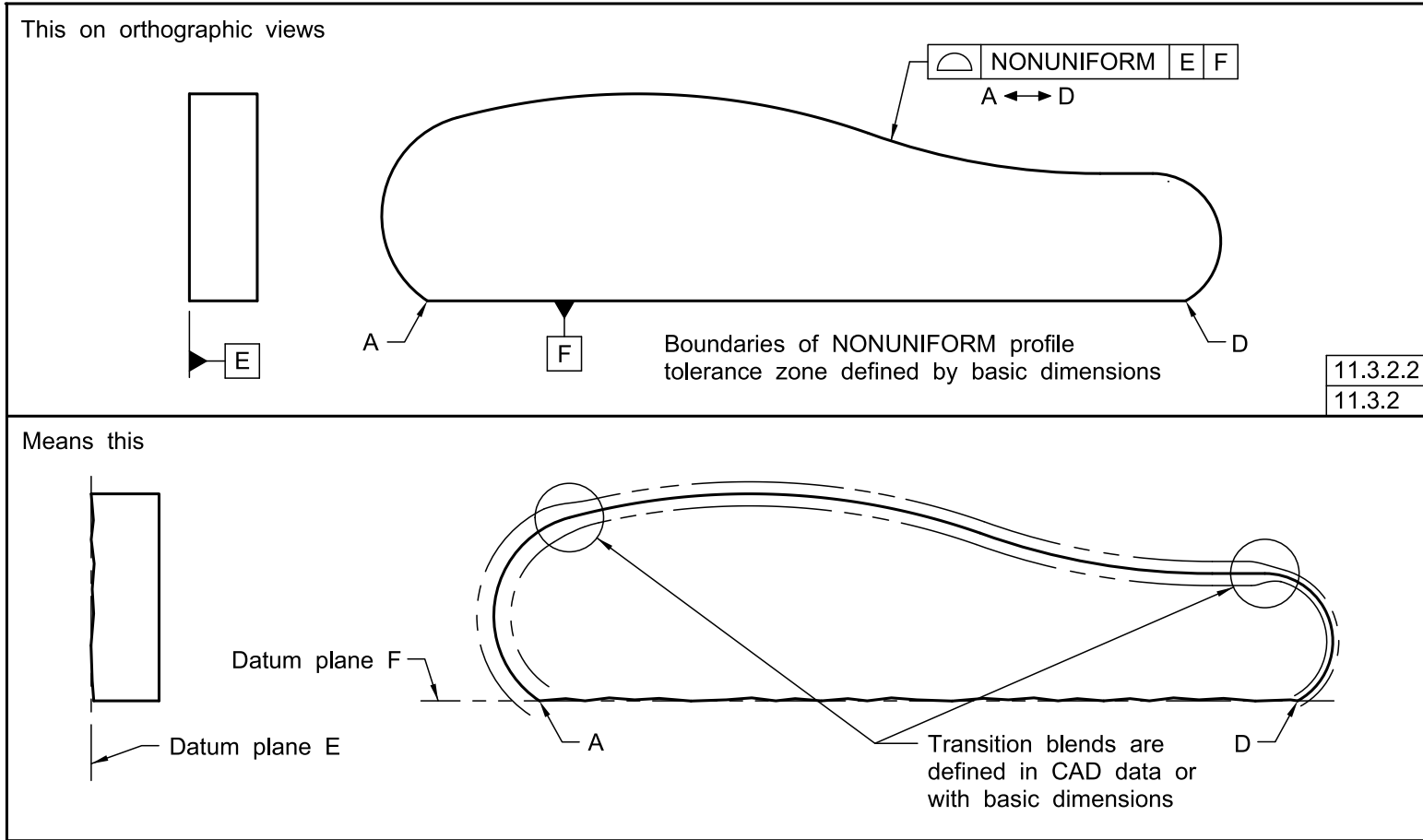
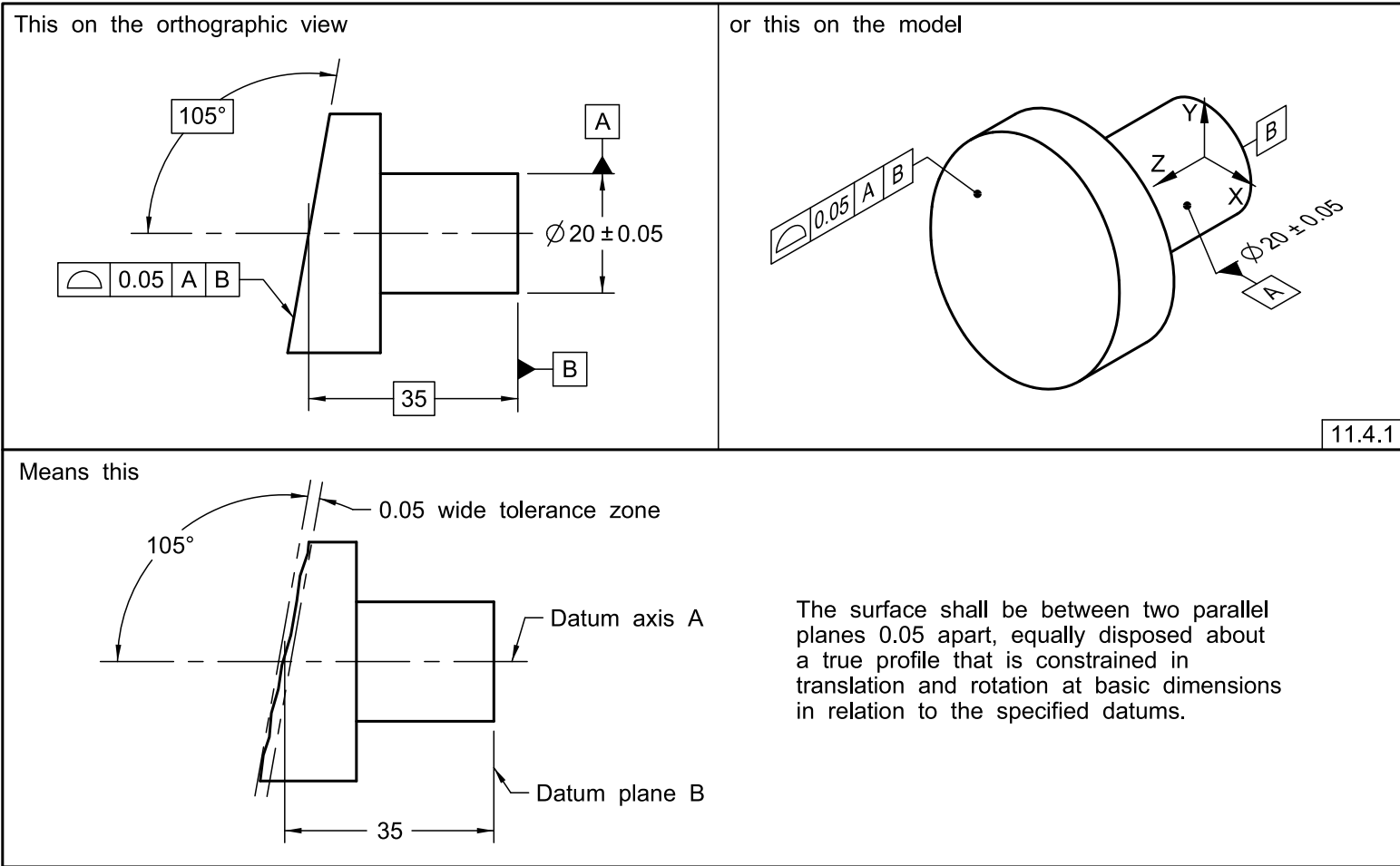
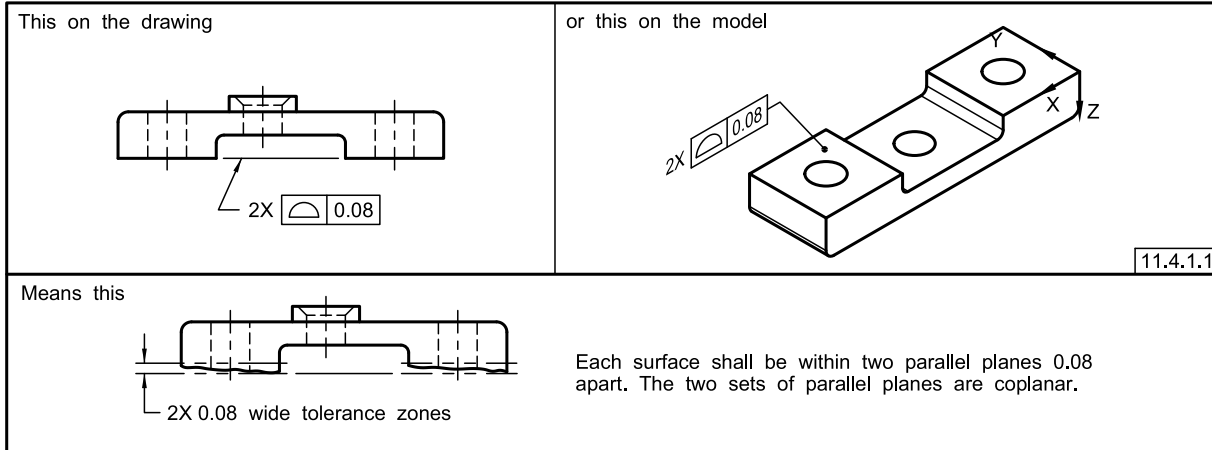

Figure 11-15 Specifying the Profile of a Surface for a Plane Surface



11.4.1

Figure 11-16 Specifying the Profile of a Surface for Coplanar Surfaces



11.4.1.1

Figure 11-17 Specifying the Profile of a Surface for Coplanar Surfaces to a Datum Established by Two Surfaces

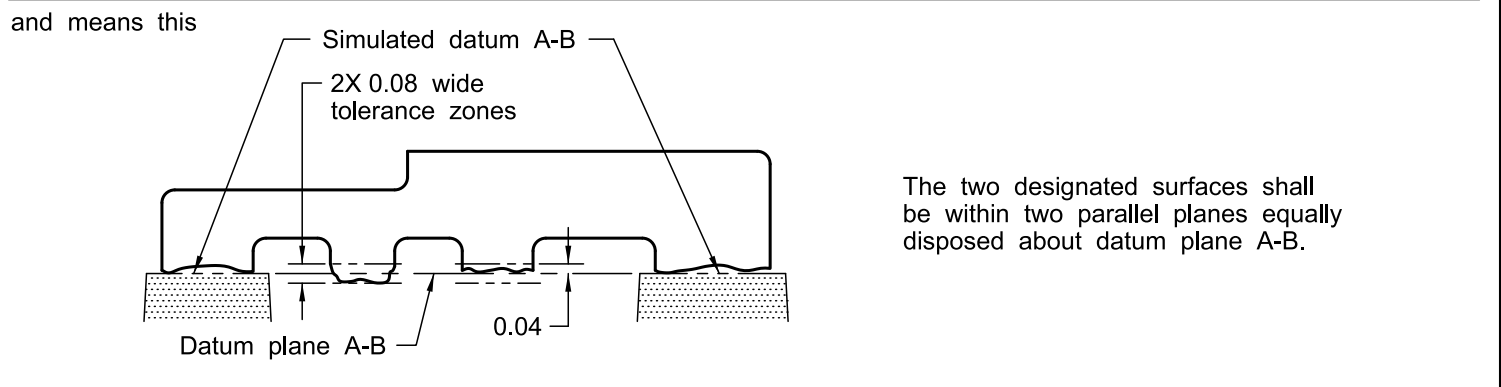
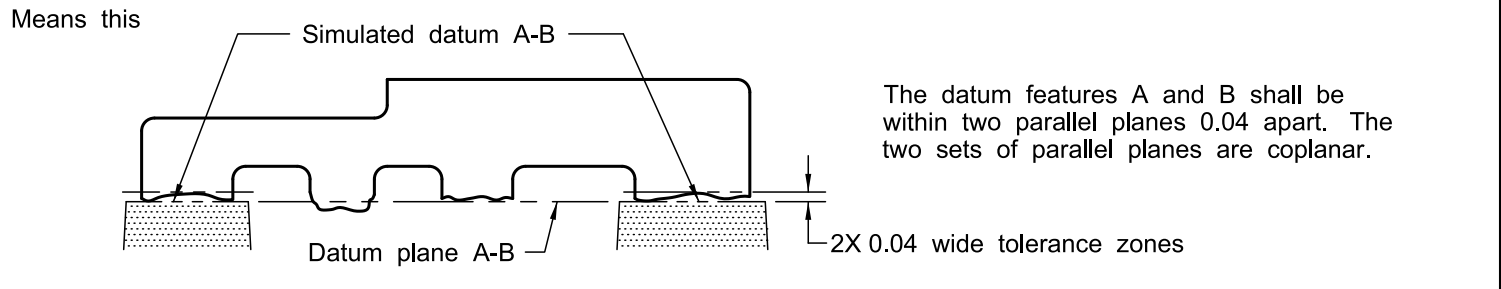
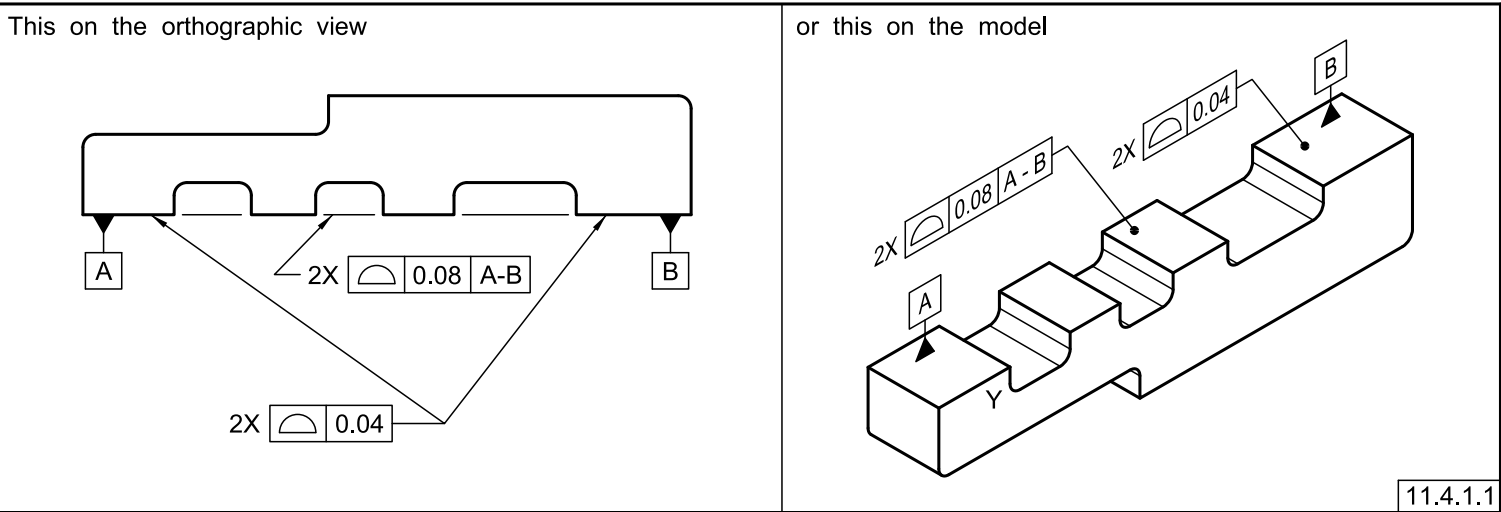

Figure 11-18 Specifying the Profile of a Surface for Stepped Surfaces

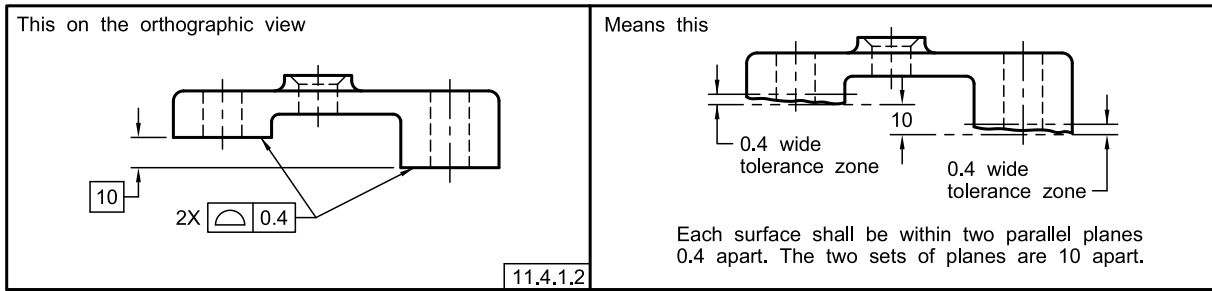

Figure 11-19 Specifying the Profile of a Conical Feature

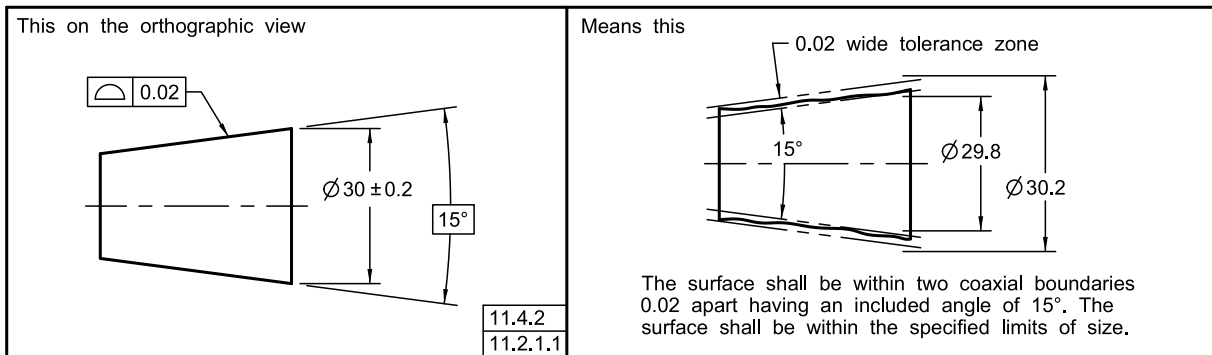

Figure 11-20 Profile Tolerancing of a Conical Feature, Datum Related

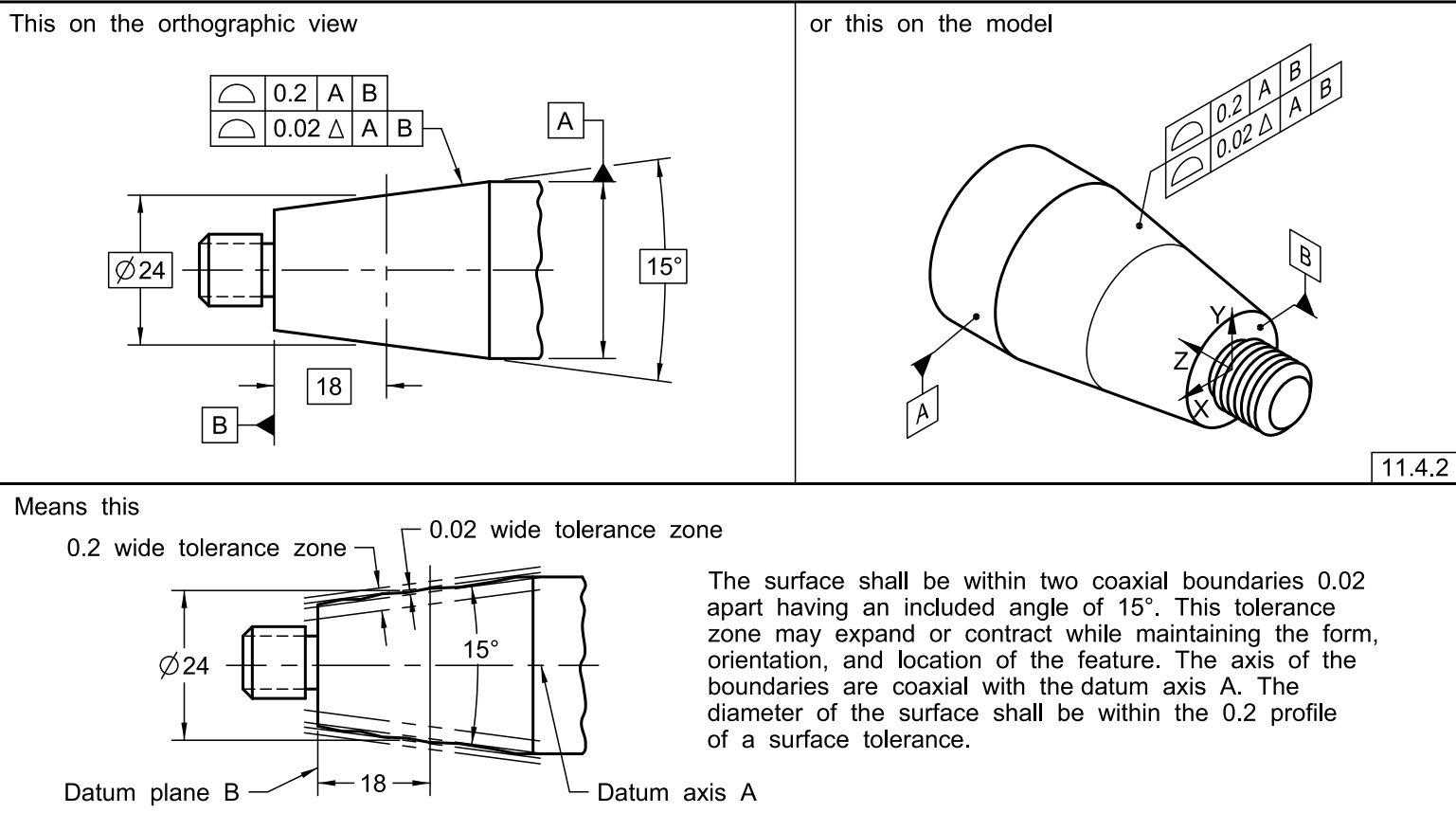
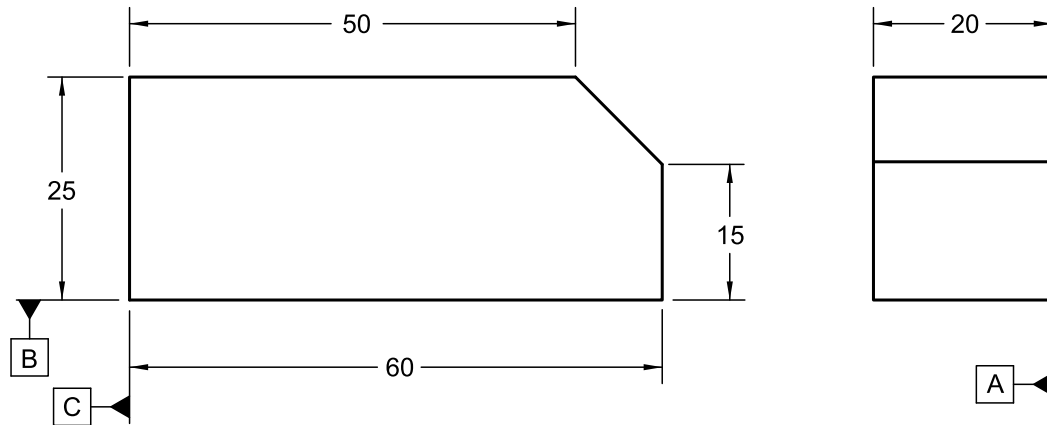
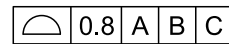

Figure 11-21 The Toleranced Feature Is a Referenced Datum Feature

This on the orthographic views



UNLESS OTHERWISE SPECIFIED: DIMENSIONS ARE BASIC



11.4.3.1

Means this

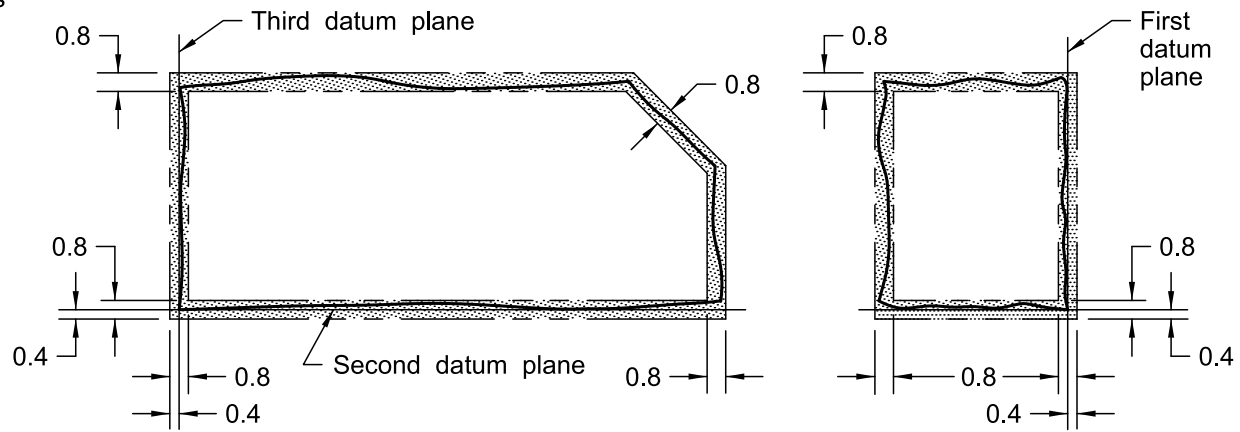

Shaded areas show unusable portion of the tolerance zone.

Figure 11-22 The Toleranced Feature Includes Referenced Datum Targets

This on the orthographic views

UNLESS OTHERWISE SPECIFIED:
DIMENSIONS ARE BASIC

	0.8	A	B	C
--	-----	---	---	---

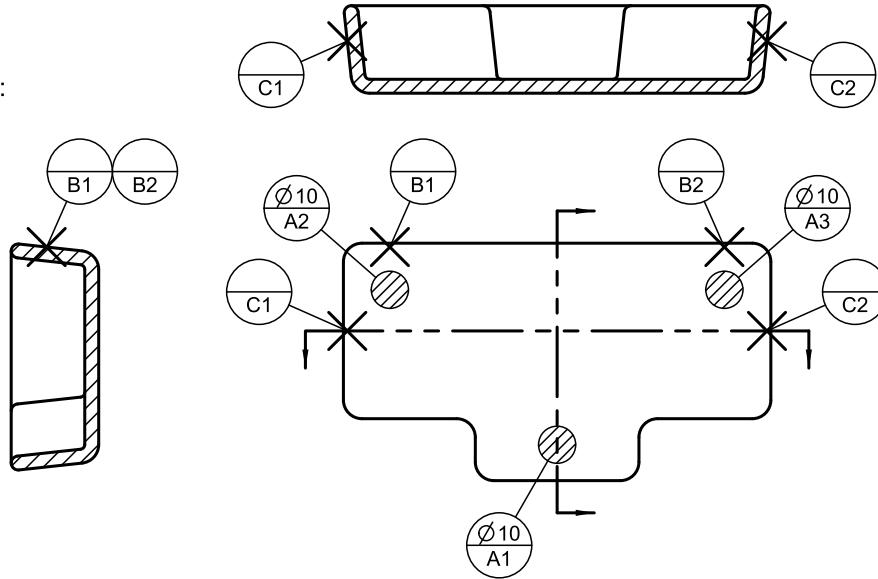

11.4.3.2

Means this

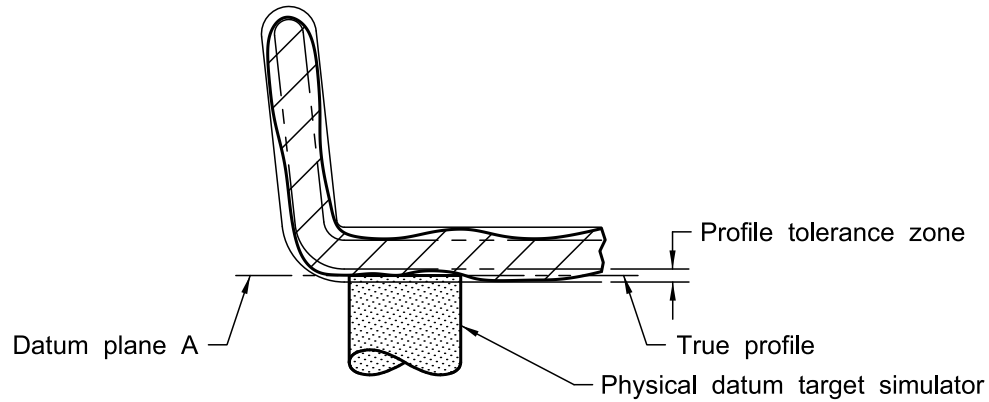
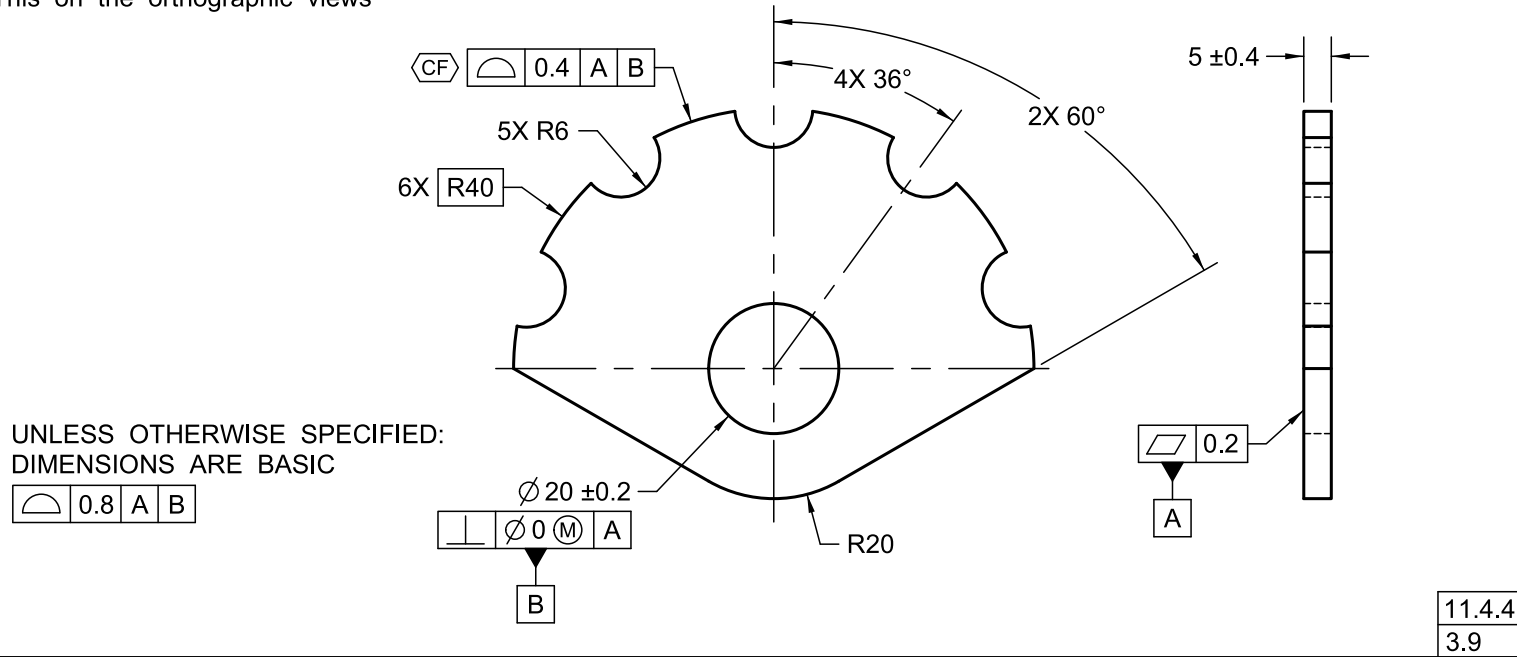

Figure 11-23 "Continuous Feature" Symbol Application in a Profile Tolerance

This on the orthographic views



Means this

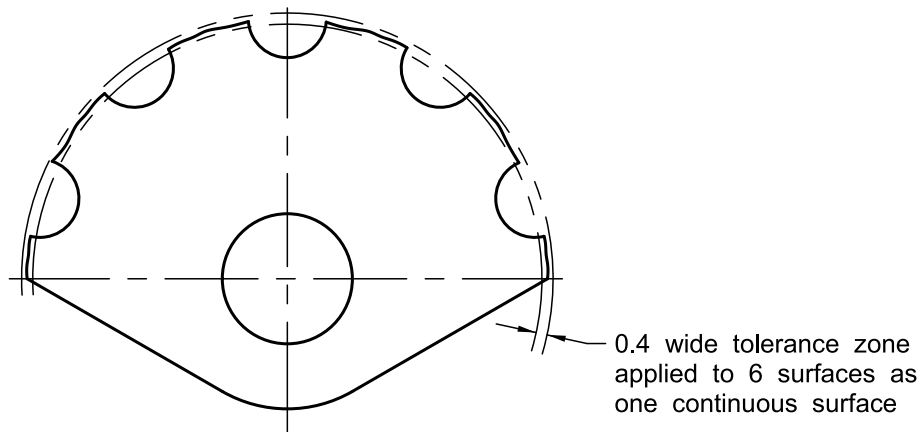

Figure 11-24 Composite Profile Tolerancing of an Irregular Feature

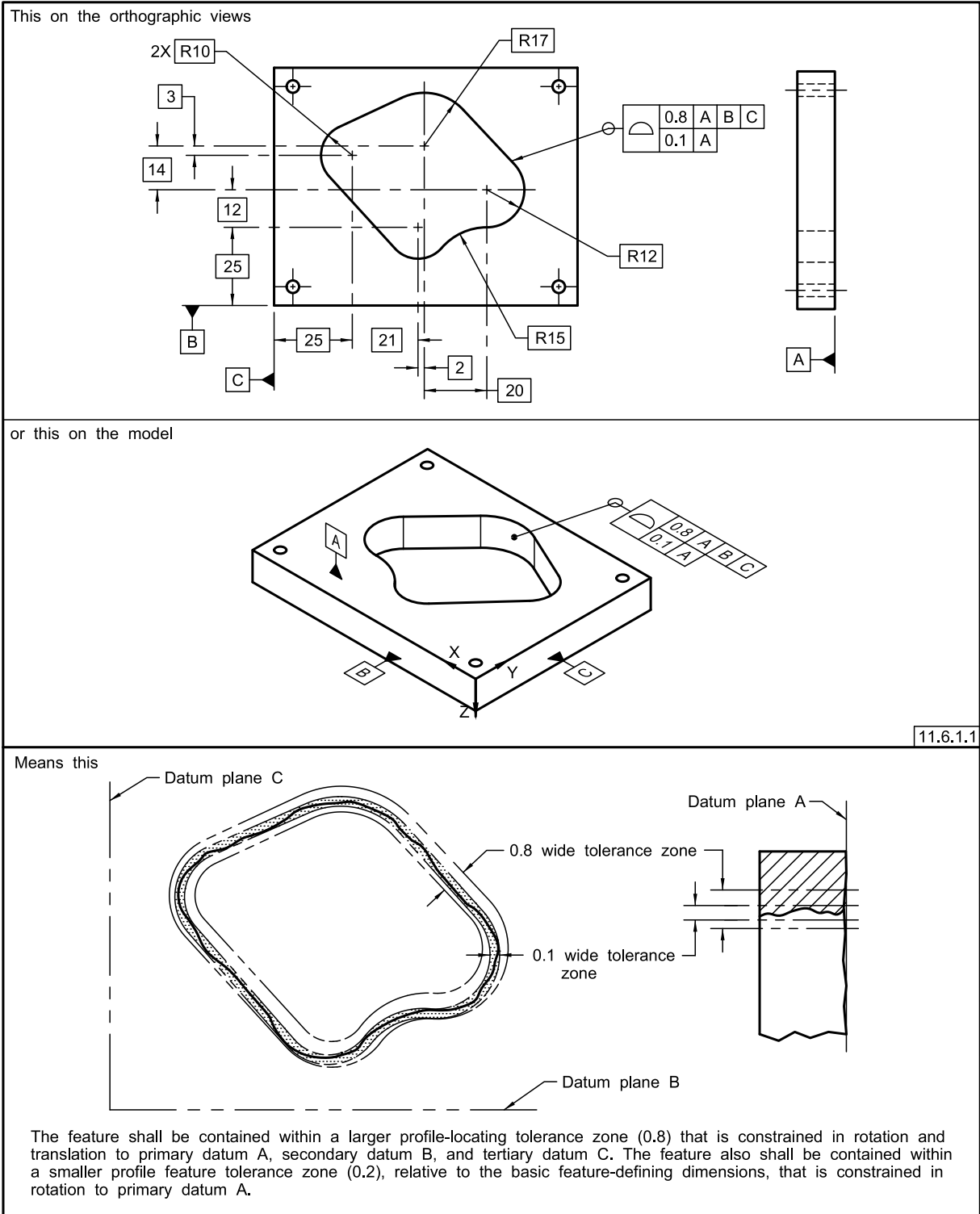

Figure 11-25 Composite Profile Tolerancing of a Feature

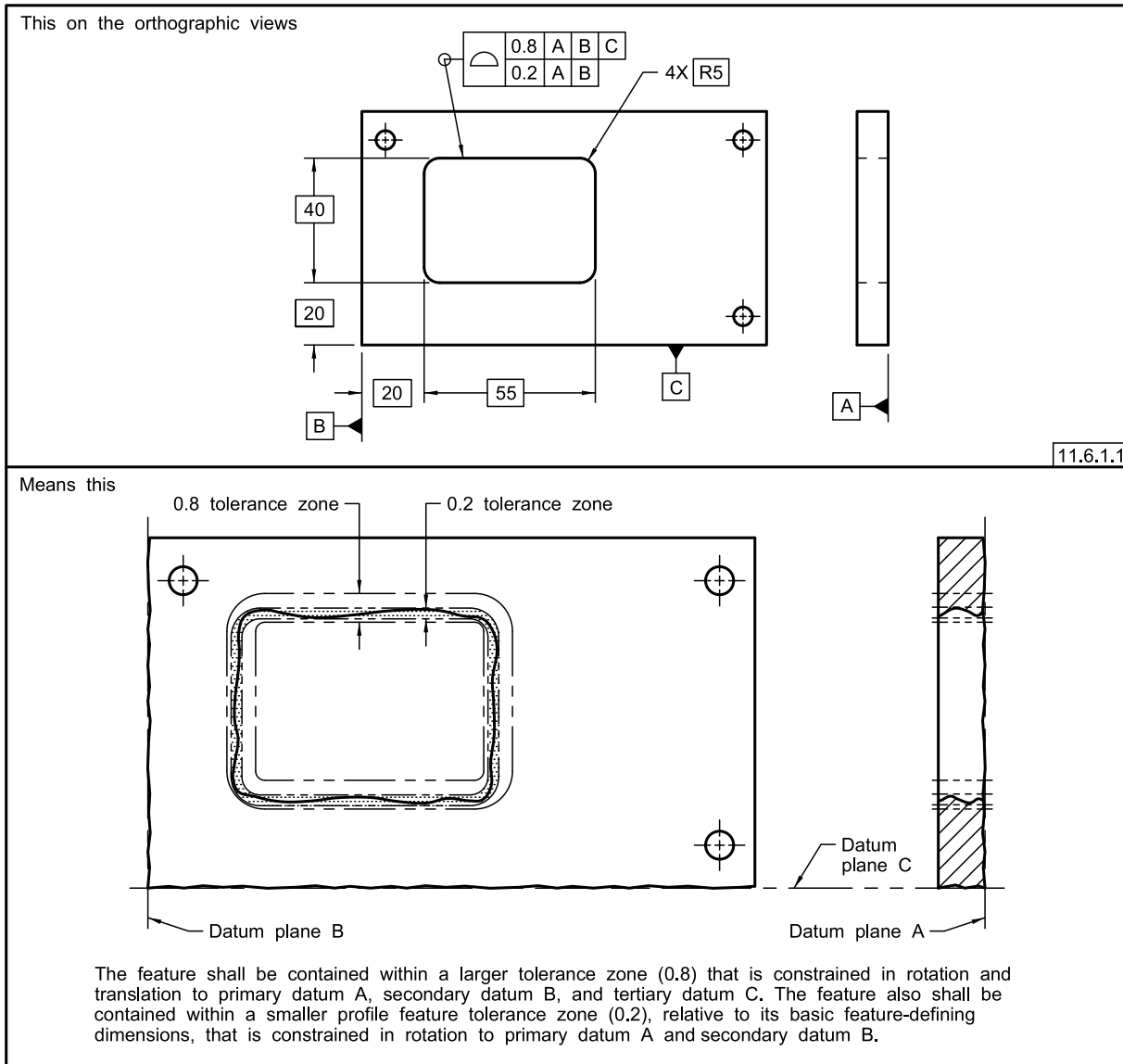

Figure 11-26 Pattern Located by Composite Profile Tolerancing — Repeated Primary Datum Feature Reference

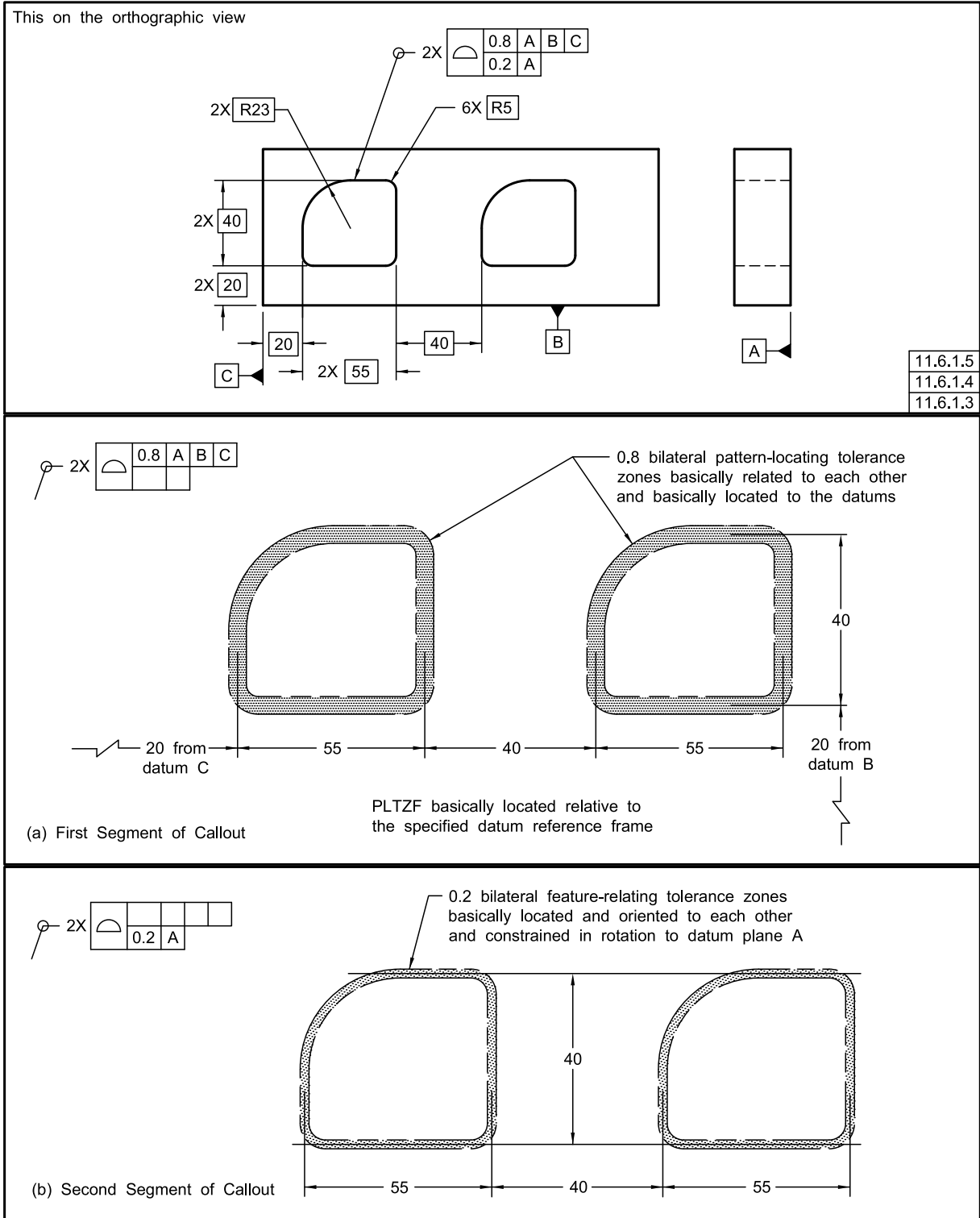

Figure 11-26 Pattern Located by Composite Profile Tolerancing — Repeated Primary Datum Feature Reference (Cont'd)

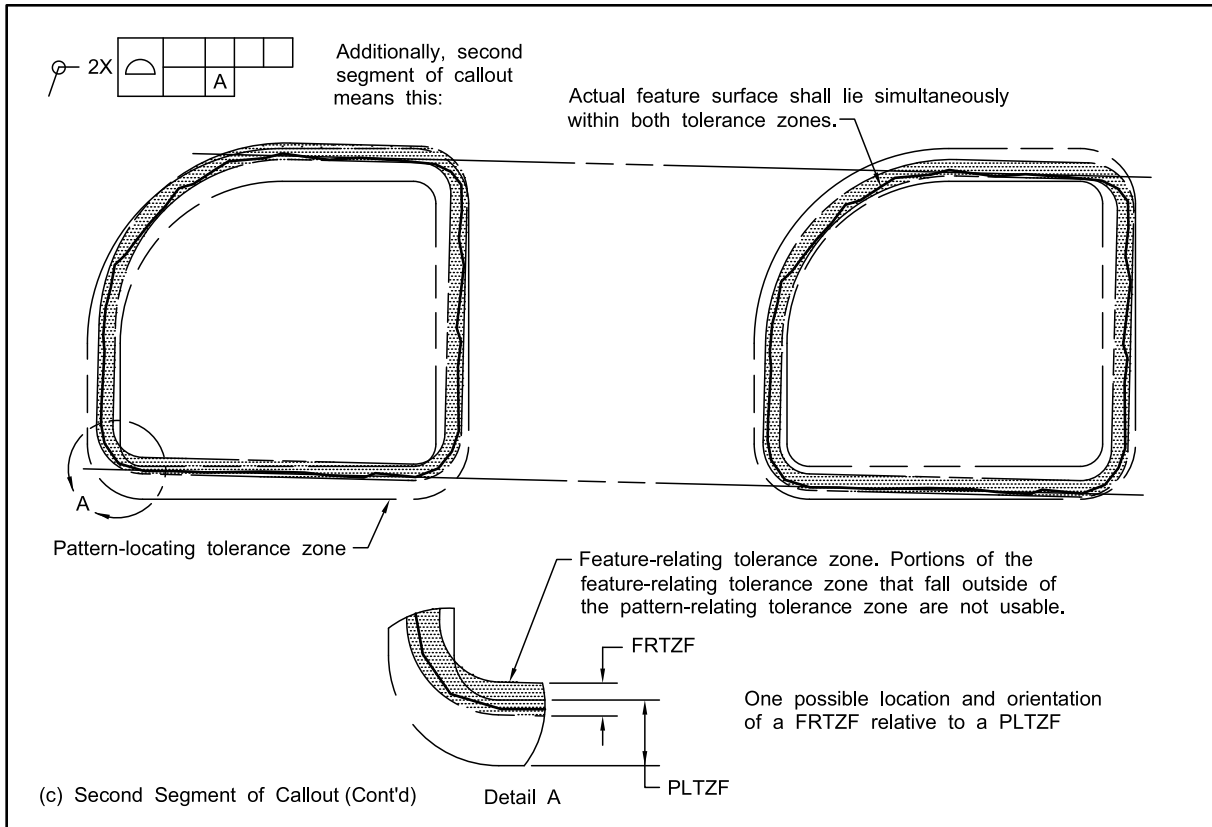

Figure 11-26 Pattern Located by Composite Profile Tolerancing — Repeated Primary Datum Feature Reference (Cont'd)

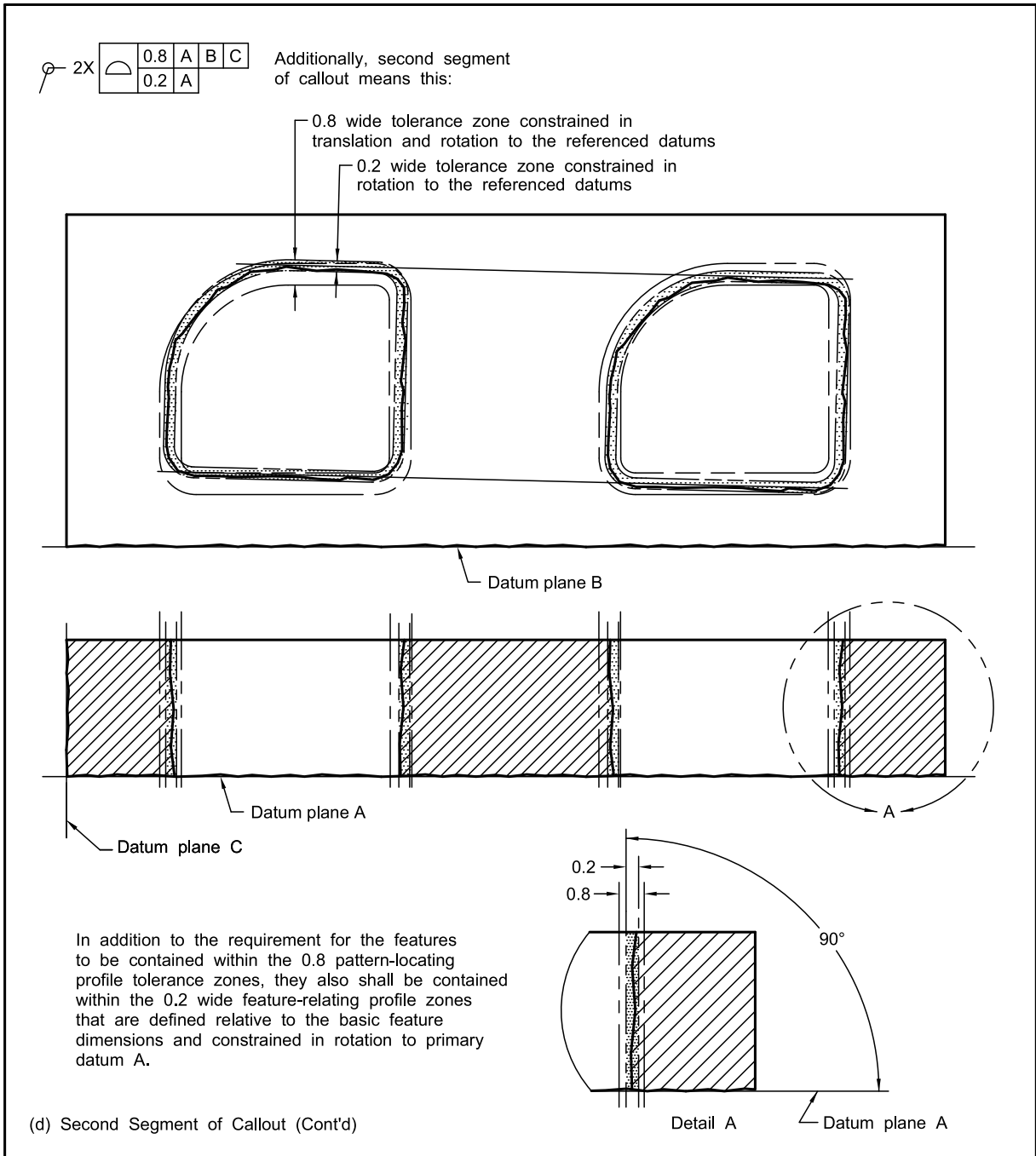

Figure 11-27 Pattern Located by Composite Profile Tolerancing — Repeated Primary and Secondary Datum Feature References

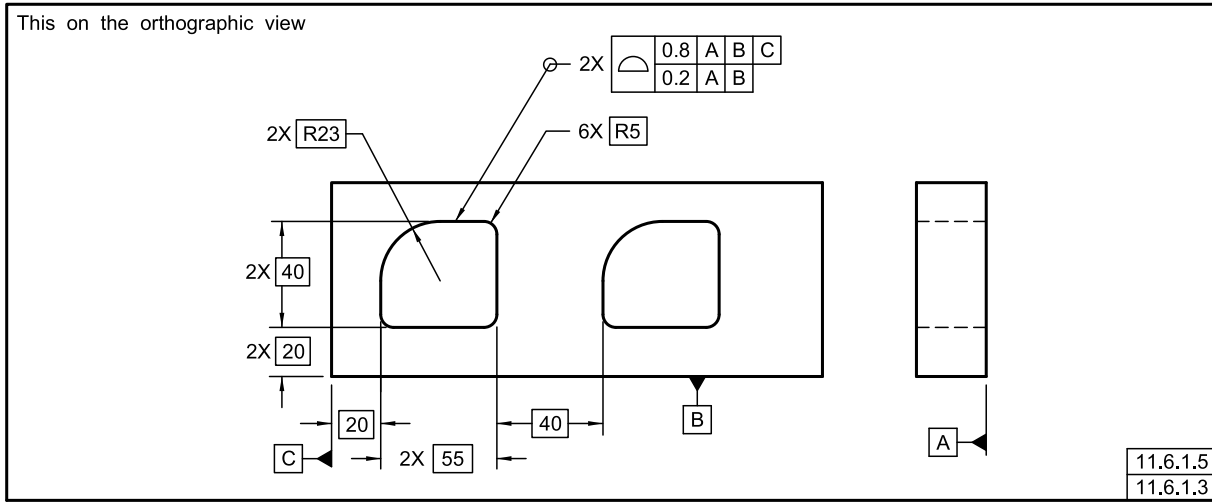

Figure 11-27 Pattern Located by Composite Profile Tolerancing — Repeated Primary and Secondary Datum Feature References (Cont'd)

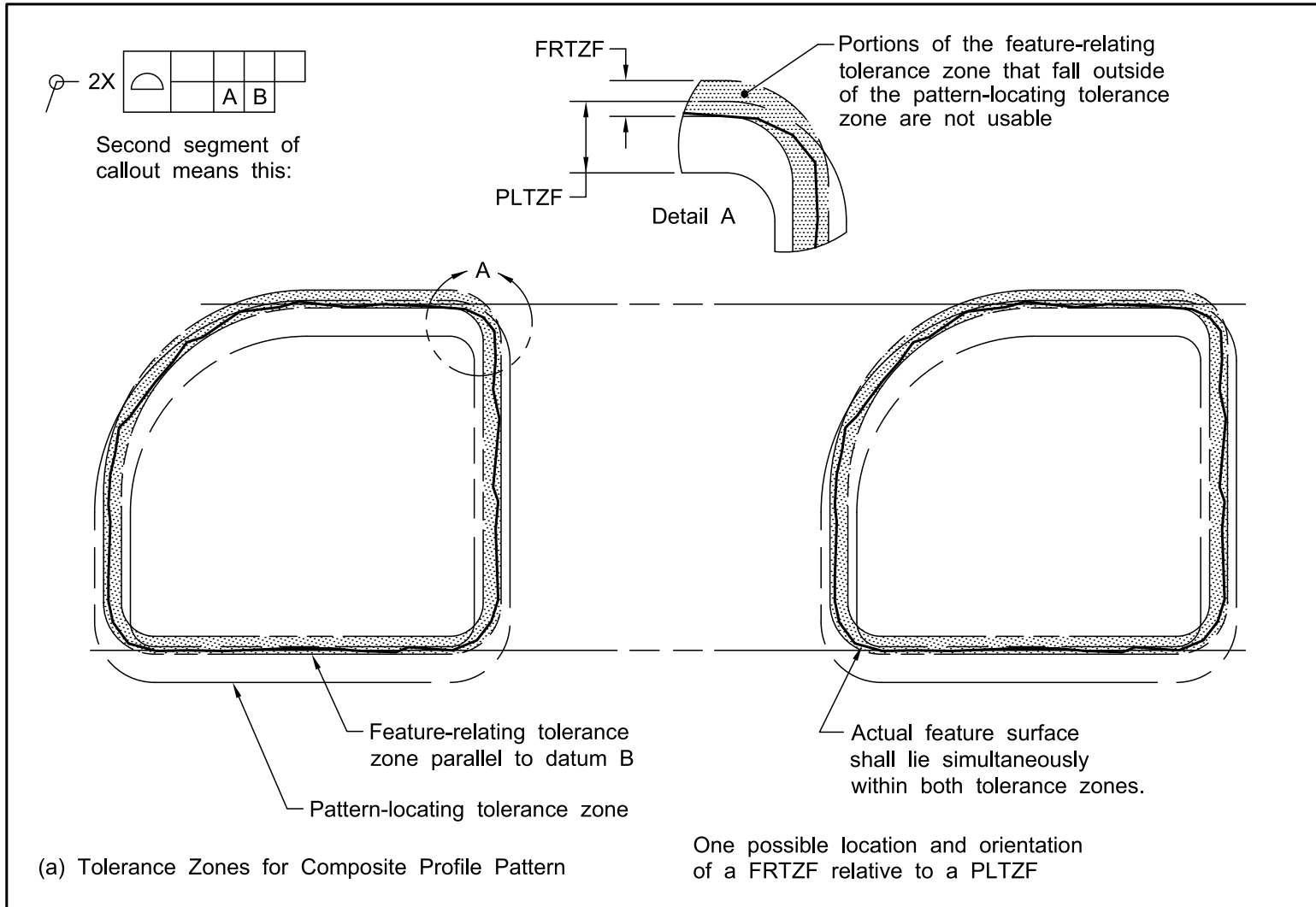

Figure 11-27 Pattern Located by Composite Profile Tolerancing — Repeated Primary and Secondary Datum Feature References (Cont'd)

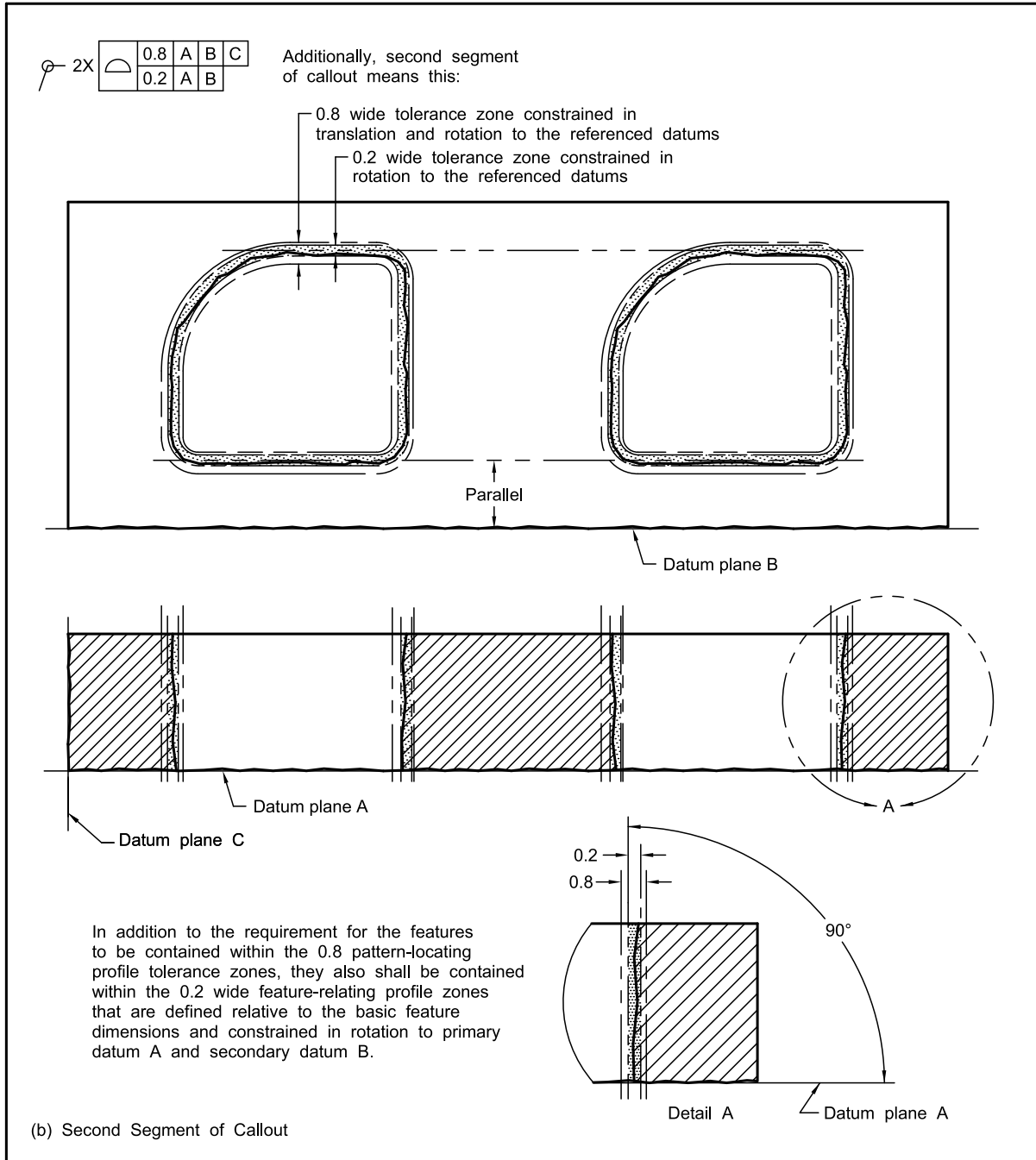
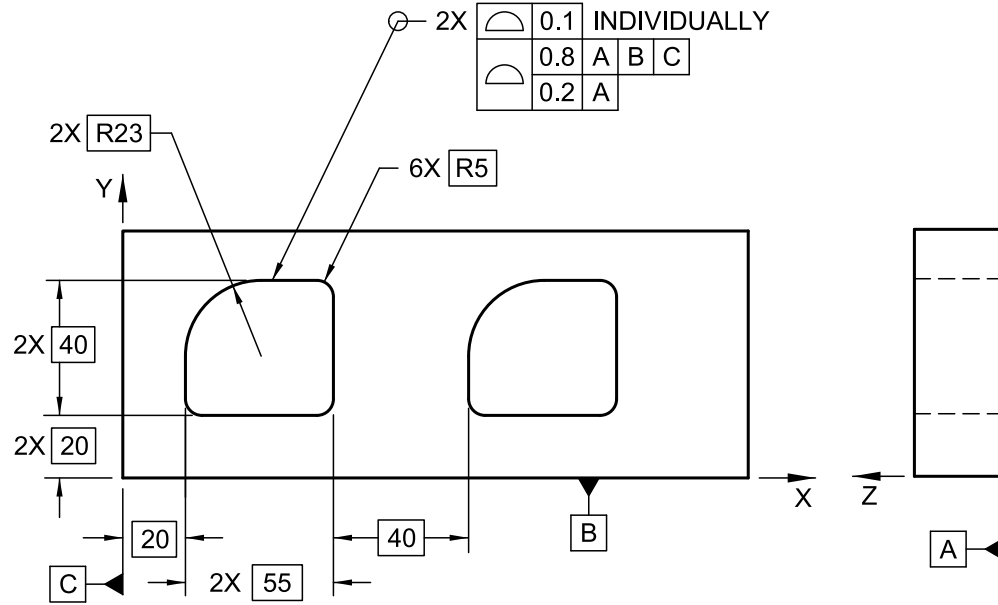
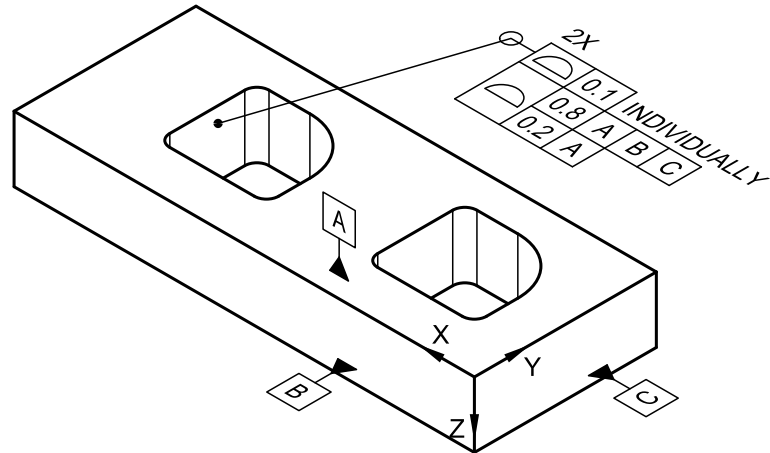

Figure 11-28 Irregular Shaped Feature With a Profile Size/Form Control and the Pattern Located by Composite Profile Tolerance

This on the orthographic views



or this on the model



11.6.2

Figure 11-29 MMC Principle Used With Profile Controls

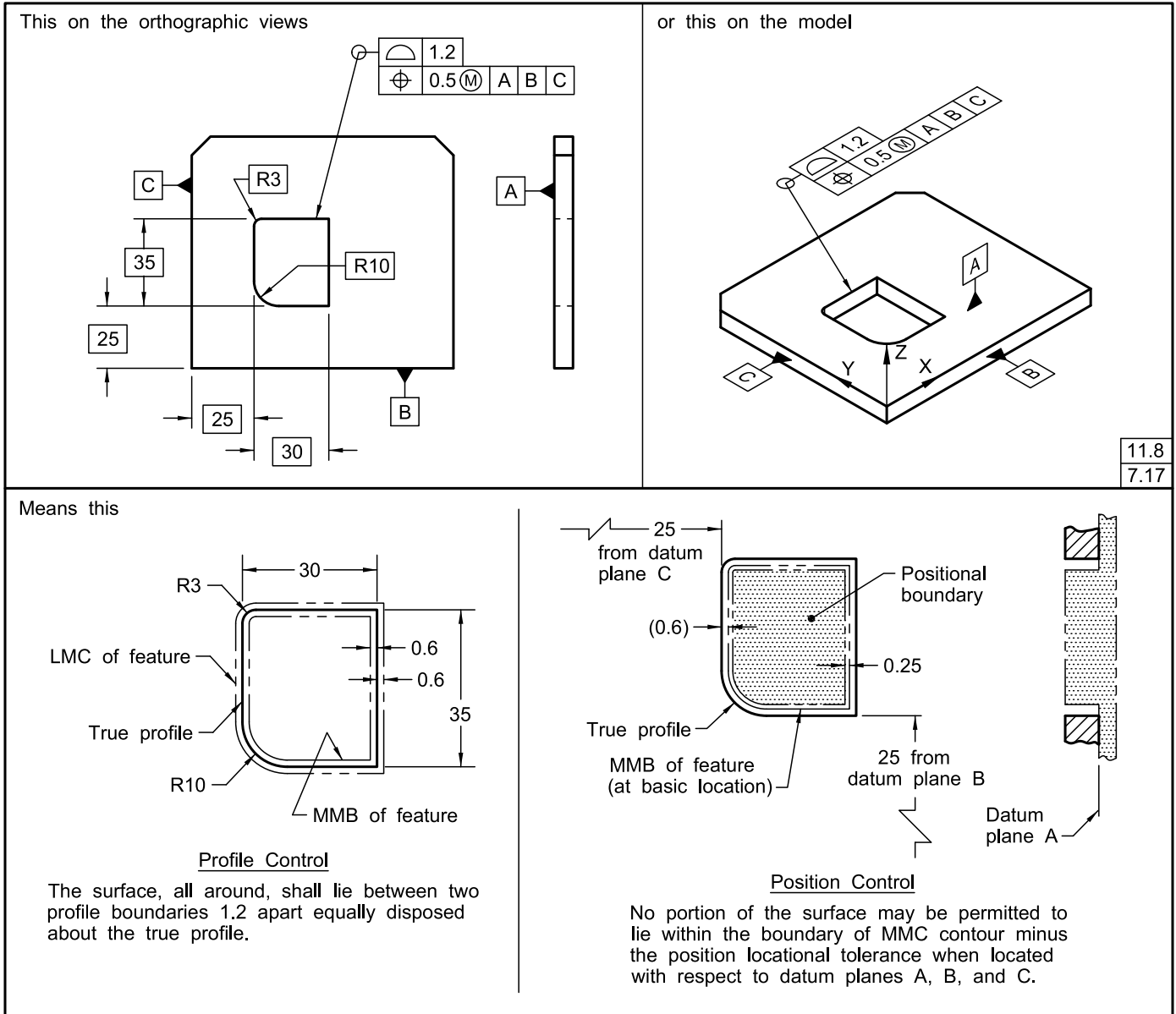
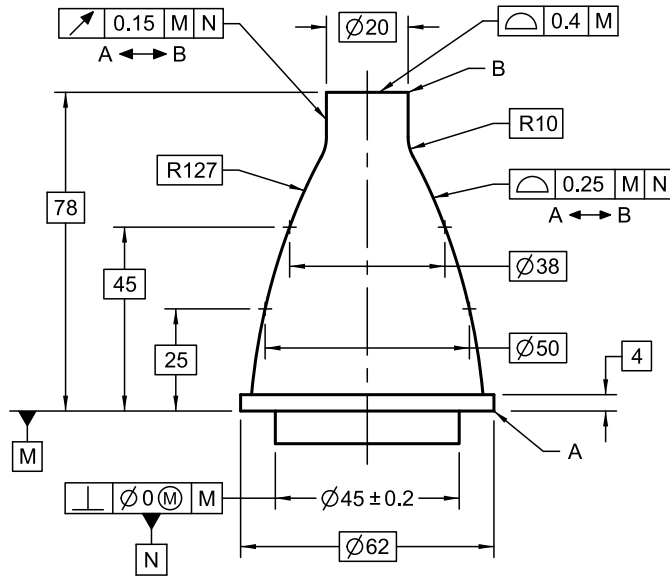

Figure 11-30 Profile of a Surface of Revolution

This on the orthographic view



11.8

Means this

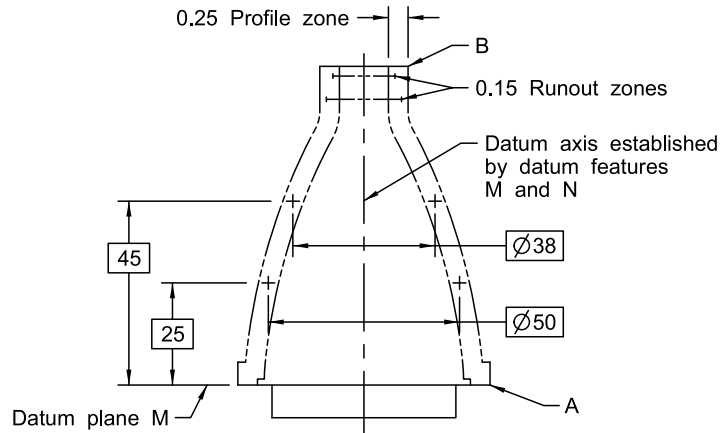

The surface between A and B shall be within two profile boundaries 0.25 apart, equally disposed about the true profile and positioned with respect to the primary plane M and secondary datum axis N. Additionally, each circular element of the surface shall be within the 0.15 runout tolerance.

Figure 11-31 Specifying the Combined Profile of a Surface and a Line Tolerance

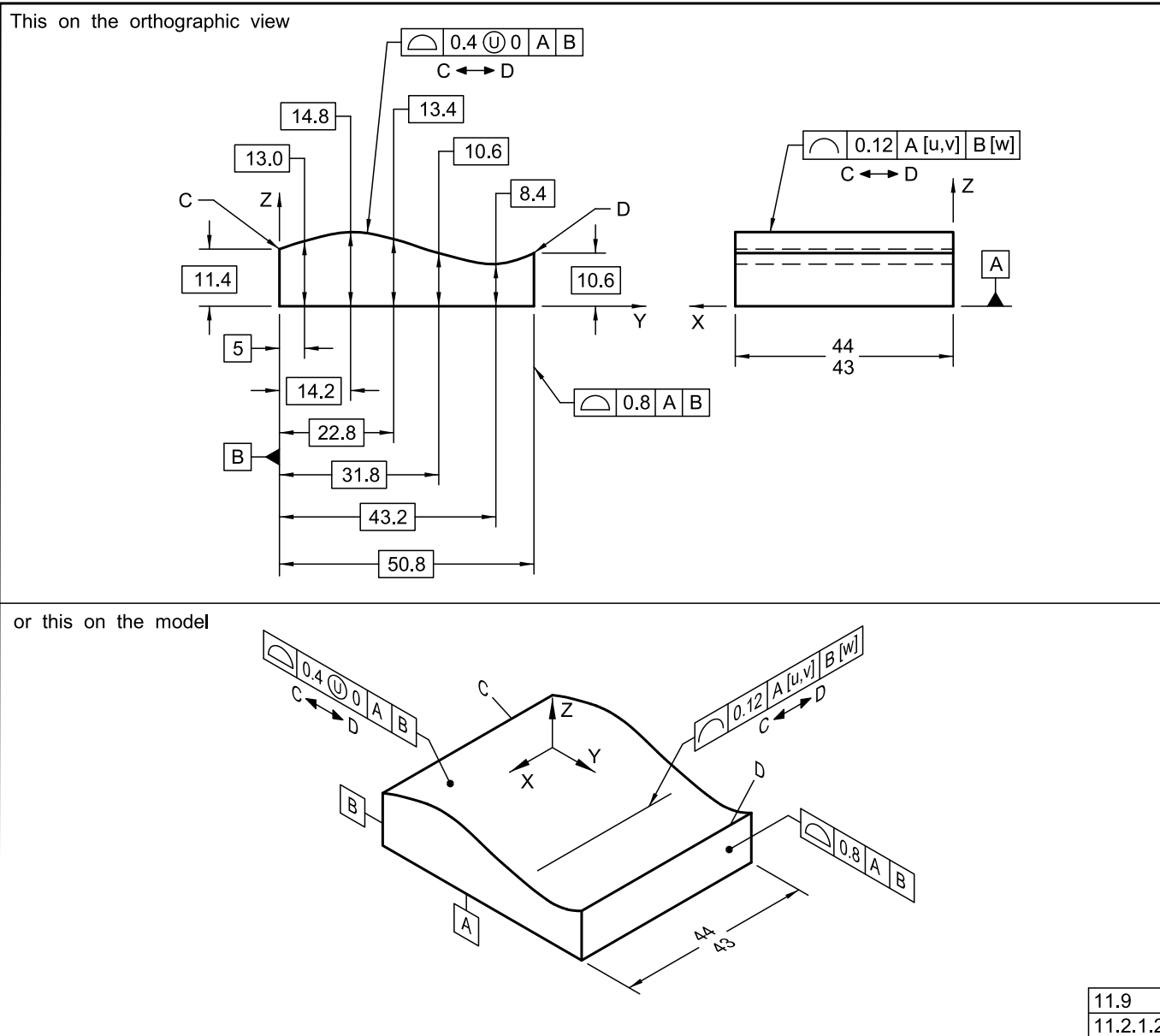
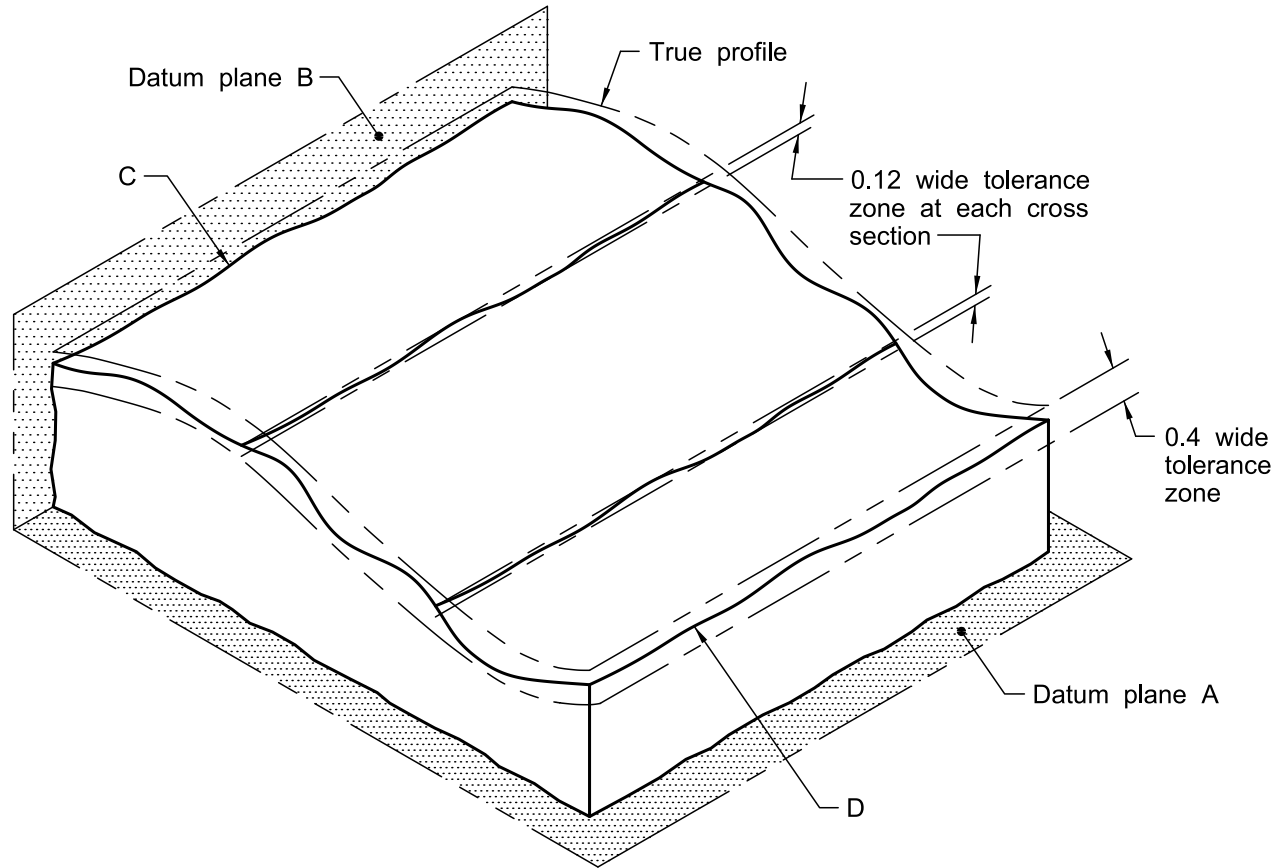

Figure 11-31 Specifying the Combined Profile of a Surface and a Line Tolerance (Cont'd)

Means this



The surface between C and D shall lie within the unilateral profile tolerance zone that has one boundary coincident with the true profile and the other boundary inside of the true profile and located with respect to datum planes A and B. Each line element of the considered surface shall be within two lines 0.12 apart that are parallel to datum plane A and constrained in rotation to datum plane B.

Figure 11-32 Profile of a Line and Size Control

This on the orthographic views

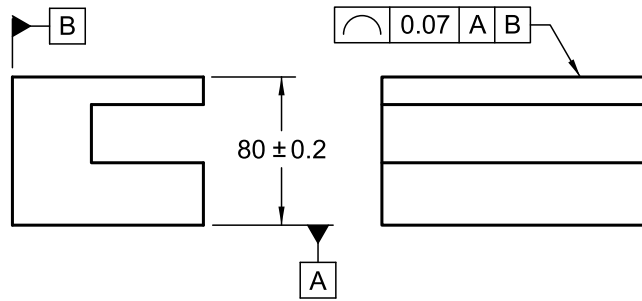

or this on the model

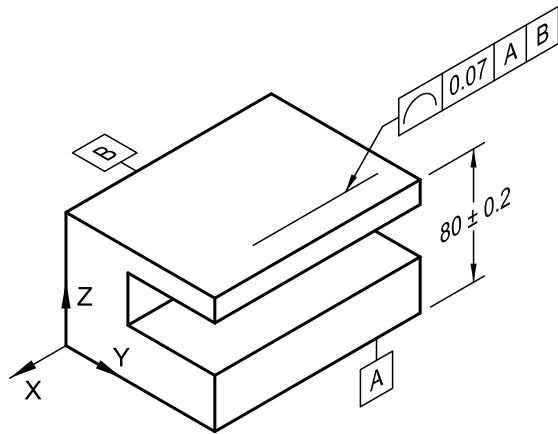

11.9
11.2.1.2

Means this

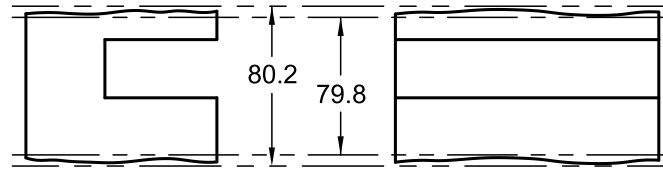

80 ± 0.2 size tolerance zone

The surfaces shall be within the specified limits of size.

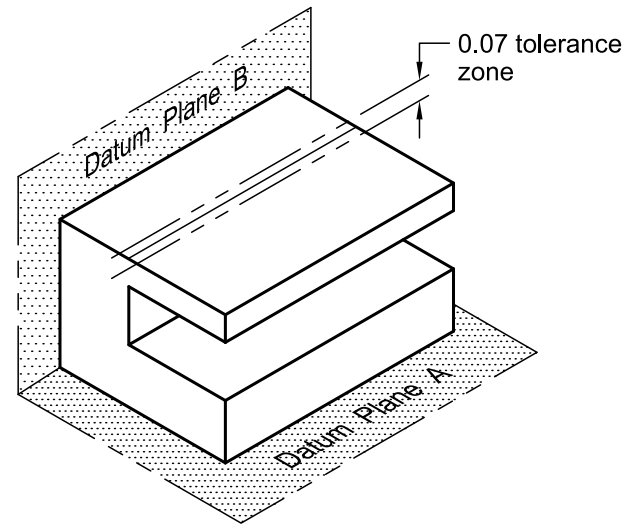

Each longitudinal element of the surface shall be within two parallel lines 0.07 apart relative to datum planes A and B.

Figure 11-33 Specifying Perpendicularity for a Radial Element of a Surface

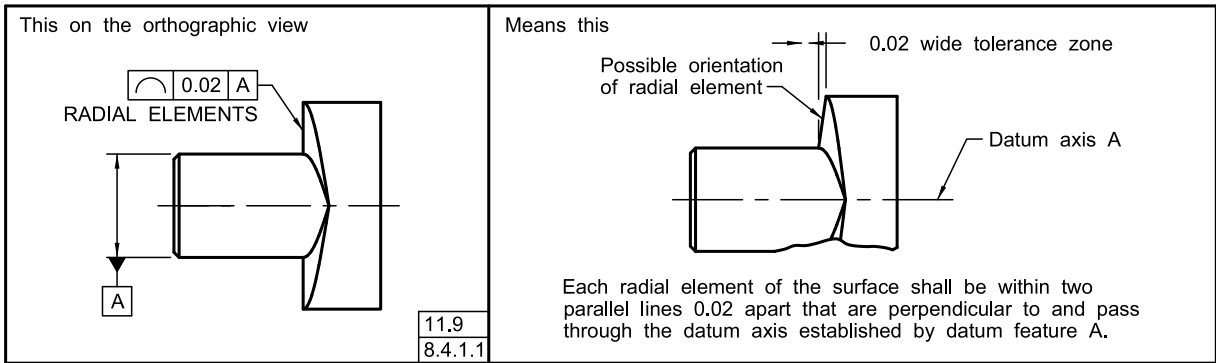

Figure 11-34 Constrained Degree of Freedom Used With Profile of a Line

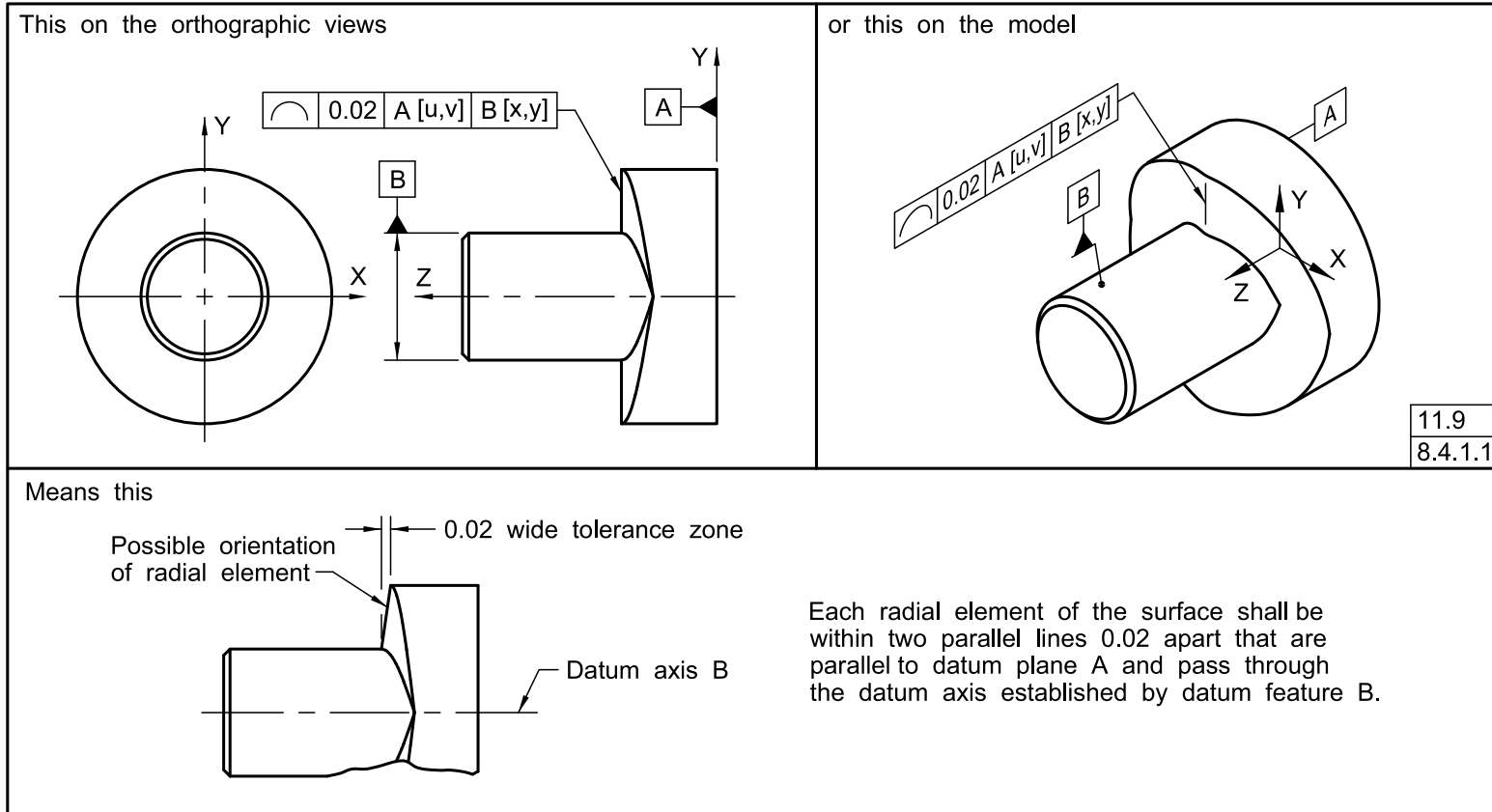

Figure 11-35 Composite Profile With Dynamic Profile to Control Form

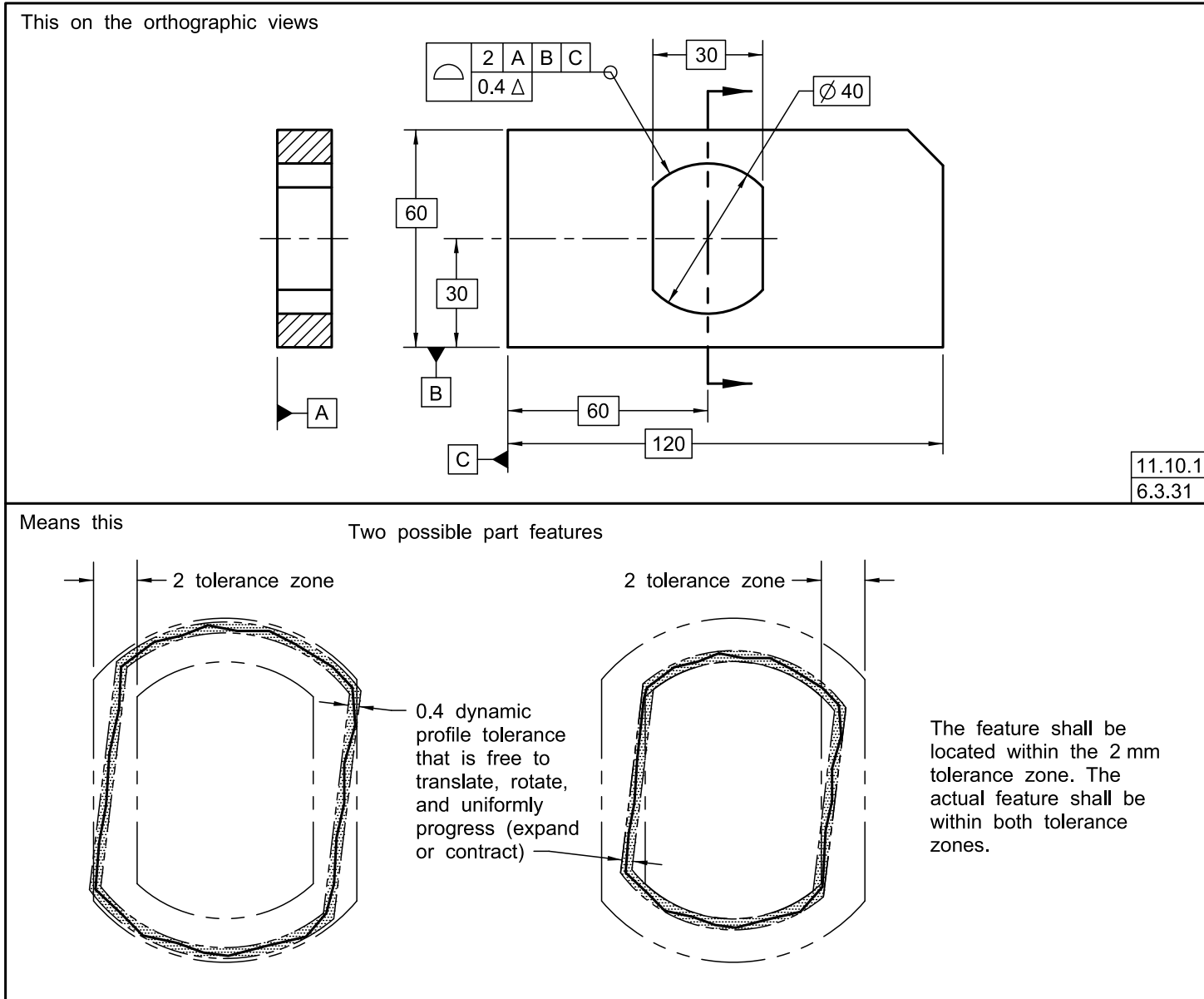

Figure 11-36 Composite Profile With Dynamic Profile to Control Form and Constrain Rotational Degrees of Freedom

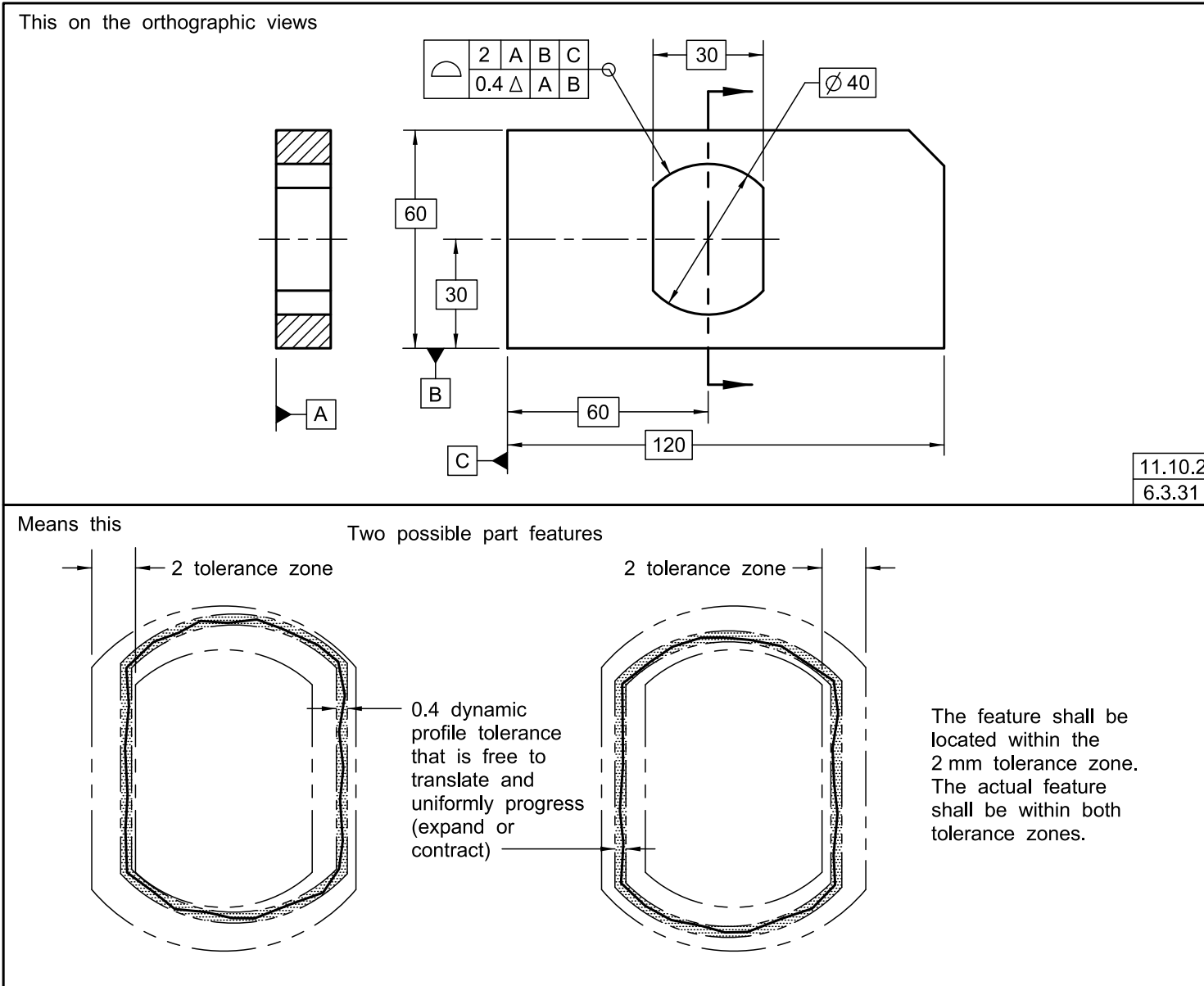

Figure 11-37 Use of Dynamic Profile in a Two-Segment Profile Tolerance

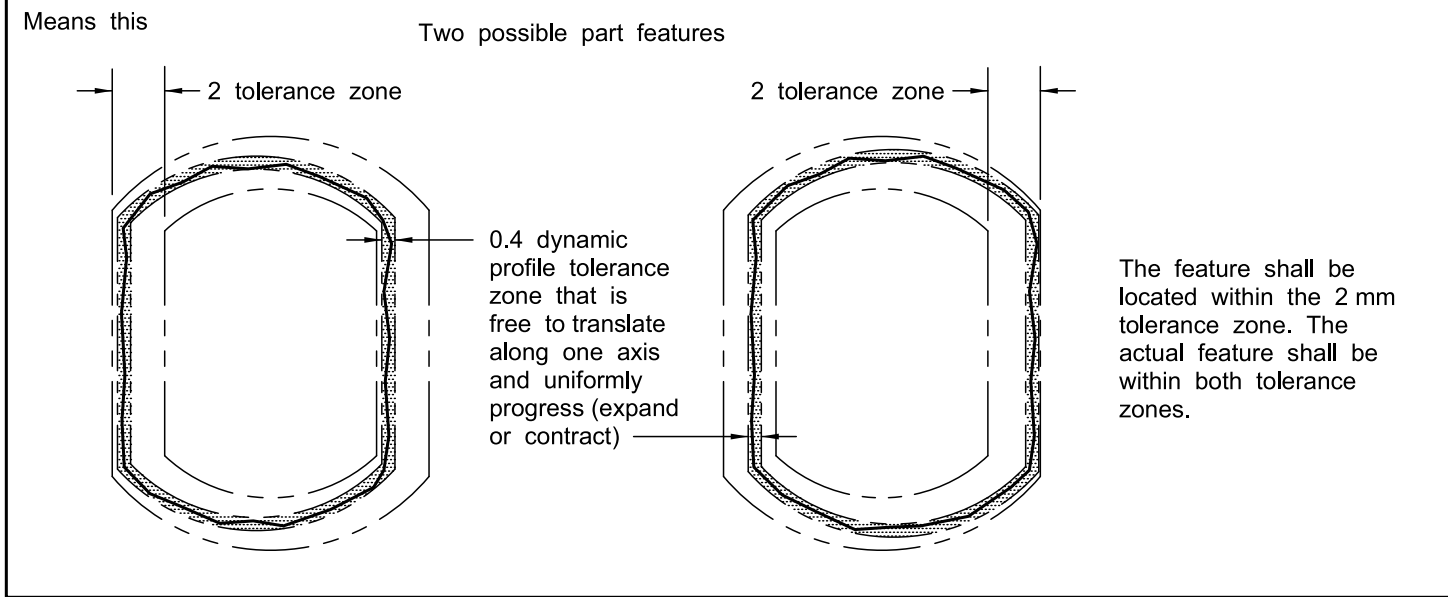
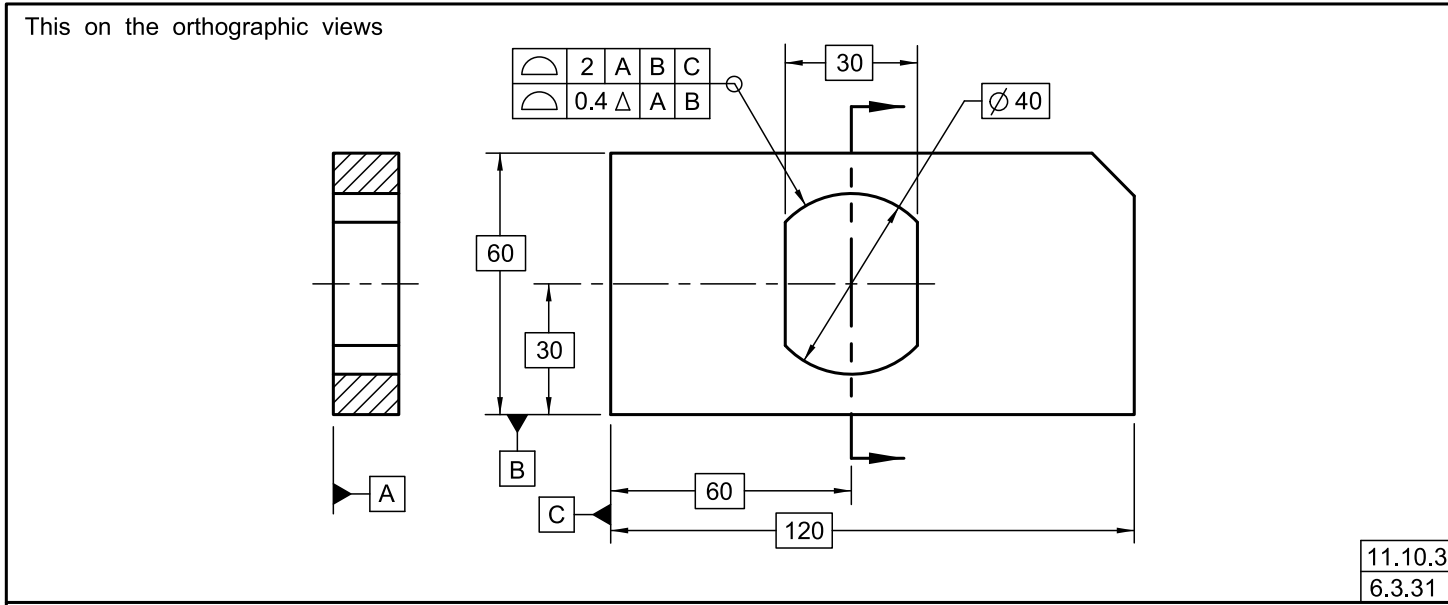
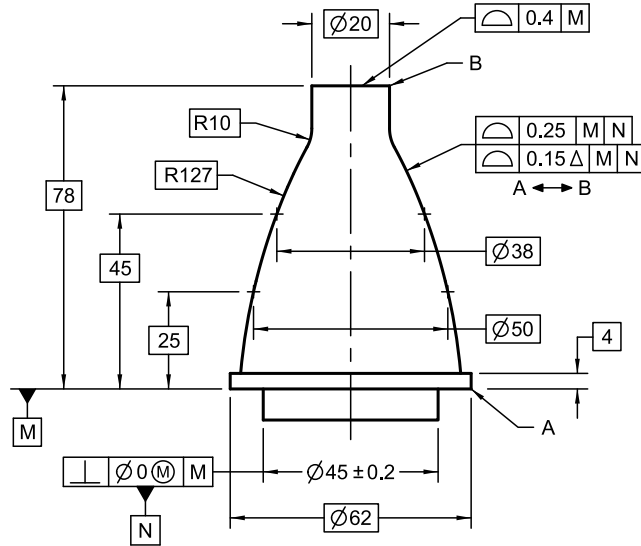

Figure 11-38 Dynamic Profile of a Surface of Revolution

This on the orthographic view



11.10.4
6.3.31

Means this

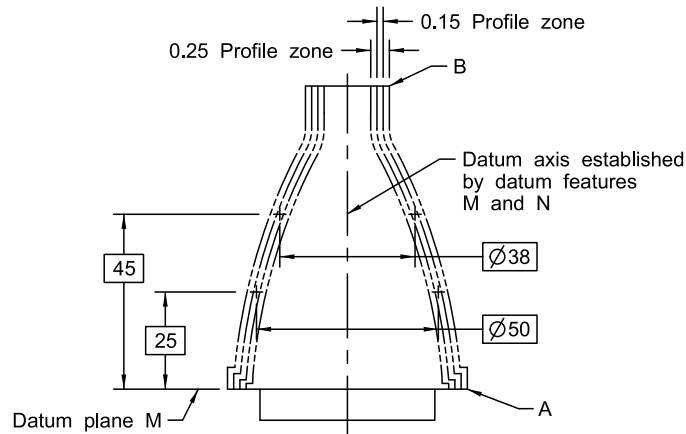

The surface between A and B shall be within two dynamic profile zones 0.25 apart, equally disposed about the true profile and positioned with respect to the primary plane M and secondary datum axis N. Additionally, the surface shall be within the 0.15 dynamic profile tolerance zone. These boundaries also are constrained in translation and rotation with respect to primary plane M and secondary datum axis N but may progress (expand and contract) within the 0.25 profile zone.

Section 12

Tolerances of Runout

12.1 GENERAL

This Section establishes the principles and methods of dimensioning and tolerancing to control runout of various geometrical shapes.

12.2 RUNOUT

Circular runout and total runout are geometric tolerances used to control applicable characteristics of surfaces of revolution relative to the datum axis RMB.

12.3 RUNOUT TOLERANCE

The types of features controlled by runout tolerances include those surfaces constructed around a datum axis and those constructed at right angles to a datum axis. See [Figure 12-1](#). When applied to a feature of size, runout tolerances may be greater than, equal to, or less than the size tolerance of the considered feature.

12.3.1 Datum Features for Runout Tolerances

The datum axis for a runout tolerance should be established by a cylindrical datum feature of sufficient length, two or more cylindrical datum features having sufficient axial separation, or a cylindrical datum feature(s) in combination with a face at a right angle to the cylindrical feature(s). Features used as datum features for establishing axes should be functional, such as mounting features that establish an axis of rotation. When runout is applied on an assembly, the axis of rotation may not be a datum axis. See [para. 12.6.8](#).

12.3.2 Degrees of Freedom Constrained

The tolerance zone is constrained in translation and rotation relative to the datum axis or axis of rotation. The tolerance zone shall contain all controlled elements for each considered feature within the specified runout tolerance. This may also include the datum features as a part of the runout tolerance control where so designated.

12.4 TYPES OF RUNOUT TOLERANCES

There are two types of runout tolerances: circular runout and total runout. The type used is dependent on design requirements and manufacturing considerations. Circular runout is normally a less complex require-

ment than total runout. [Paragraphs 12.4.1](#) through [12.4.3](#) describe both types of runout and their resulting tolerance zones. When a surface is controlled by a runout tolerance, intended interruptions of a surface, such as keyways or holes, do not affect the tolerance zone boundaries, and the extent of the boundaries is limited to where there is material.

12.4.1 Control of Circular Elements

Circular runout provides control of circular elements of a surface relative to the datum axis. A tolerance zone is created and applied independently to each circular cross section of the surface of the part.

(a) When applied to cylindrical, conical, and curved surfaces constructed around a datum axis, circular runout controls the cumulative variations of form and coaxiality. See [Figure 12-2](#). When a limited area of application is specified, the location of the area shall be dimensioned from and referenced to a datum reference frame. See [para. 12.4.3](#) and [Figure 12-2](#).

(b) When applied to surfaces constructed at right angles to the datum axis, circular runout controls circular variations (wobble) of a plane surface. See [Figure 12-3](#).

12.4.1.1 Circular Runout Tolerance Zone for Nonplanar Features. When a circular runout tolerance is applied to a surface of revolution, all cross sections on the surface are independent and each circular runout tolerance zone is bounded by two circles that are coaxial (constrained in translation) to the datum axis and lie in a plane(s) normal (constrained in rotation) to the datum axis. The distance between these circles is normal to the true geometry, and the circles are separated by a radial distance equal to the specified circular runout tolerance. See [Figure 12-2](#).

12.4.1.2 Circular Runout Tolerance Zone for Planar Features. When a circular runout tolerance is applied to a planar surface perpendicular to the axis of rotation, all circular elements on the surface are independent and each circular runout tolerance zone is bounded by two circles of the same diameter that are centered on the axis of rotation and axially separated by a distance equal to the specified circular runout tolerance. See [Figure 12-3](#).

12.4.2 Total Runout for Control of Surfaces

Total runout provides control of all surface elements of the considered feature. The tolerance applies simultaneously to all circular and profile elements of the surface.

(a) When applied to surfaces constructed around a datum axis, total runout controls cumulative variations such as circularity, cylindricity, straightness, and location (coaxiality) of a cylindrical surface. See [Figure 12-4](#).

(b) When applied to surfaces constructed at right angles to the datum axis, total runout controls cumulative variations such as flatness, straightness, and perpendicularity (to detect wobble) of a planar surface. See [Figure 12-5](#).

12.4.2.1 Total Runout Tolerance Zone for Cylindrical Features. All surface elements shall be within a tolerance zone consisting of two coaxial cylinders with a radial separation equal to the tolerance value specified. The tolerance zone is constrained in translation (coaxial) to the datum axis. See [Figure 12-4](#).

12.4.2.2 Total Runout Tolerance Zone for Planar Features. All surface elements shall be within a tolerance zone consisting of two parallel planes with a separation equal to the tolerance value specified. The tolerance zone is constrained in rotation (normal) to the datum axis. See [Figure 12-5](#).

12.4.3 Runout Applied to a Portion of a Surface

When a runout tolerance applies to a specific (partial) portion of a surface, a chain line may be drawn adjacent to the surface profile on one side of the datum axis for the desired length when shown in an orthographic view. Basic dimensions are used to define the location and extent of the portion indicated in this way. See [Figure 12-2](#). The "between" symbol method may also be used to indicate a limit of the specified runout control as an alternative to use of the chain line and basic dimensions defining the location and extent.

12.5 RUNOUT TOLERANCE AND SIZE

Runout tolerance and size tolerance values are based on the design requirements, and there is no requirement that runout be larger or smaller than the size tolerance. Runout and size tolerances do have combined effects on size, form, orientation, and location of the toleranced feature. See [Figure 12-6](#). Whichever tolerance is more restrictive (i.e., smaller), size or runout, establishes the tolerance of form.

12.5.1 Small Circular Runout Tolerance and Large Size Tolerance

A small circular runout tolerance may be applied on a feature that has a large size tolerance. See [Figure 12-7](#). The circular runout tolerance of 0.02 must be met at each cross

section regardless of the size at that cross section. When the runout tolerance is met, it limits size variation at each cross section to be 0.04 diameter. The variation in diameter across the entire length of the part may be the full range permitted by the size tolerance, but at each cross section, it is limited to 0.04. The resulting surface could be tapered.

12.5.2 Small Total Runout Tolerance and Large Size Tolerance

A small total runout tolerance may be applied on a feature that has a large size tolerance. See [Figure 12-8](#). The total runout tolerance of 0.02 must be met across the entire feature. When the runout tolerance is met, it limits size variation across the feature to be 0.04 diameter. This limits the size variation on any produced part to no more than 0.04. However, any part may be produced at the maximum or the minimum size, or any size between, provided the size variation does not result in exceeding the total runout tolerance.

12.5.3 Large Runout Tolerance and Small Size Tolerance

When a circular or total runout tolerance is larger than the size tolerance, the size tolerance controls variations in size and form. The larger runout tolerance controls the orientation and coaxiality to the datum axis for a surface of revolution. See [Figure 12-2](#). The larger runout tolerance controls the orientation for a planar surface at a right angle to the datum axis.

12.6 APPLICATION

The methods discussed in [paras. 12.6.1 through 12.6.8](#) are used to specify a runout tolerance and datum features in various applications. The tolerance zones apply to the full extent of the considered feature surface.

12.6.1 Control of Diameters to Datum Axis

When features to be controlled are diameters related to a datum axis, one or more of the diameters may be specified as datum features to establish the datum axis, and each related surface is assigned a runout tolerance with respect to this datum axis. [Figures 12-2 through 12-5](#) illustrate the fundamental principle of relating features in a runout tolerance to a datum axis as established from a single cylindrical datum feature of sufficient length. [Figure 12-2](#) incorporates the principle of circular runout tolerancing and illustrates the control of circular elements of a surface. [Figure 12-4](#) incorporates the principle of total runout tolerancing and illustrates the control of an entire surface.

12.6.2 Common Cylindrical Datum Features

Figure 12-9 illustrates application of runout tolerances when two cylindrical datum features collectively establish a single datum axis to which the features are related.

12.6.3 Cylindrical and Planar Datum Features

When features to be controlled are related to a cylinder and a planar surface at right angles to it, each related surface is assigned a runout tolerance with respect to the two datums. The datums are specified separately to indicate datum precedence. See Figure 12-10.

12.6.4 Control of Individual Datum Feature Surfaces

It may be necessary to control individual datum feature surface variations with respect to flatness, circularity, parallelism, straightness, or cylindricity. When such control is required, the appropriate tolerance shall be specified. See Figures 12-11 and 12-12 for examples applying cylindricity and flatness to the datum features.

12.6.5 Control of Runout to a Datum Feature(s)

Runout tolerance may be applied to a datum feature(s) and related to the datum axis derived from that datum feature(s). See Figure 12-11.

12.6.6 Relationship of Features Based on Referenced Datums

Runout tolerances are referenced to appropriate datum features to achieve the desired relationship between the features and the referenced datums. More than one datum axis may be specified to which runout tolerances are referenced. See Figure 12-11, where the runout tolerance of the hole is related to datum E rather than the axis C-D.

12.6.7 Runout Tolerance Applied to a Tangent Plane

Runout tolerance may be applied to a tangent plane for one or more coplanar feature faces that are perpendicular to an axis of rotation. UOS, for a runout tolerance applied with the tangent plane requirement, the extent of the tangent plane is circular with a radius equal to the distance from the axis of rotation to the furthest point on the surface(s) toleranced. See Figures 12-13 and 12-14. The requirements may also be specified using profile tolerances. See Figure 12-15.

12.6.8 Runout Tolerance Application on an Assembly

When specified at an assembly level, runout requirements may reference datum features that locate the assembly. The runout tolerance is relative to the axis of rotation while the axis is constrained at the basic angle relative to the datum reference frame, and the assembly is constrained in translation and rotation to the datum reference frame. See Figure 12-16, where the datum features do not establish the location of the axis of rotation, but they do constrain the orientation of the axis to ensure that the toleranced feature is within the specified runout tolerance of the assembly. Additionally, the axis of rotation may be labeled.

12.7 SPECIFICATION

In orthographic views, multiple leaders may be used to direct a feature control frame to two or more surfaces having a common runout tolerance. Surfaces may be specified individually or in groups without affecting the runout tolerance. See Figure 12-11.

Figure 12-1 Features Applicable to Runout Tolerancing

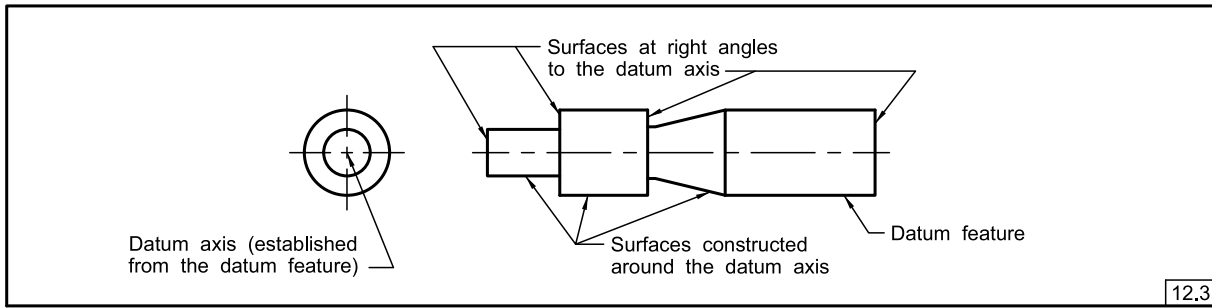

Figure 12-2 Specifying Circular Runout — Small Size Tolerance and Large Runout Tolerance

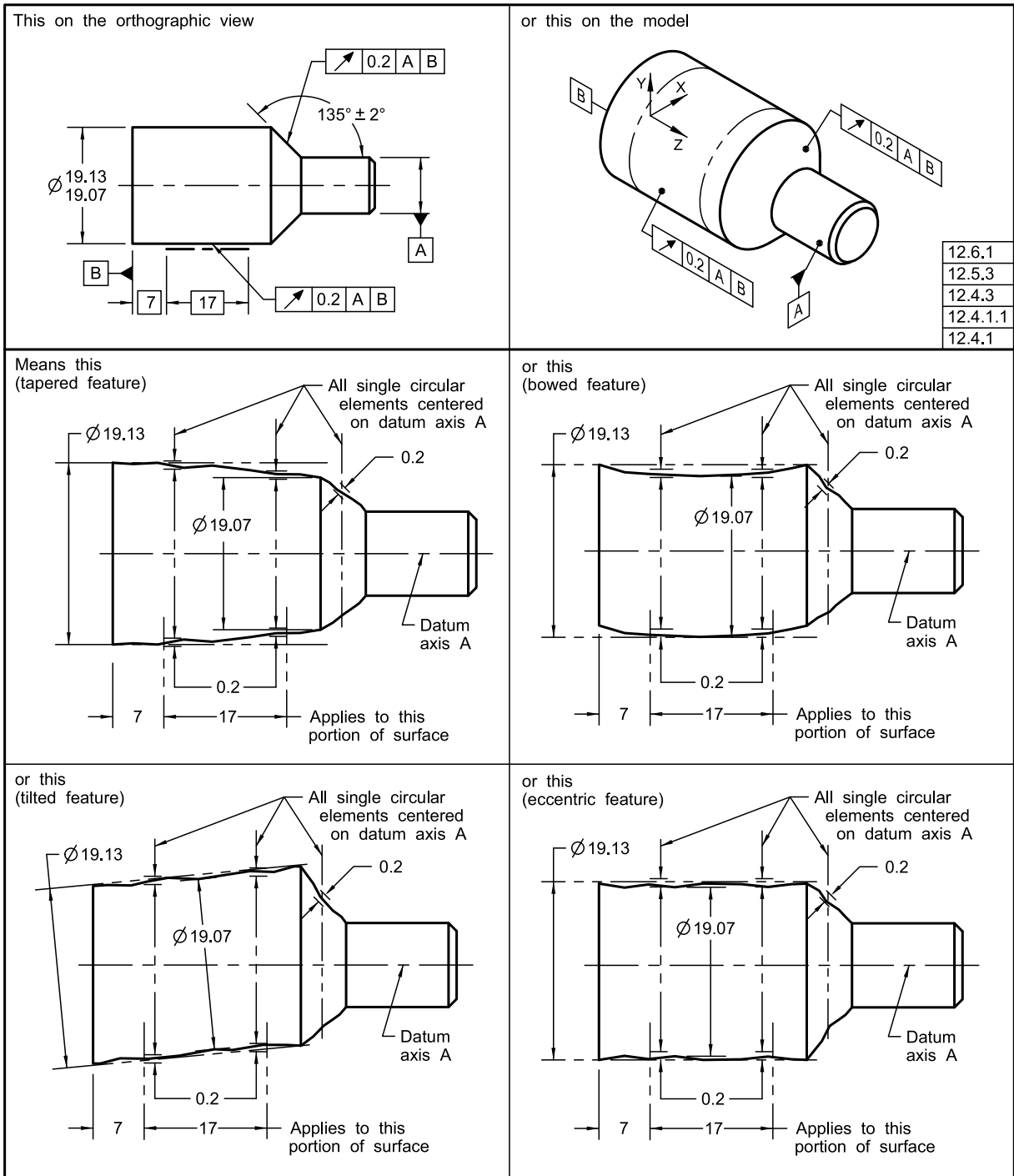

Figure 12-3 Specifying Circular Runout Relative to a Datum Axis

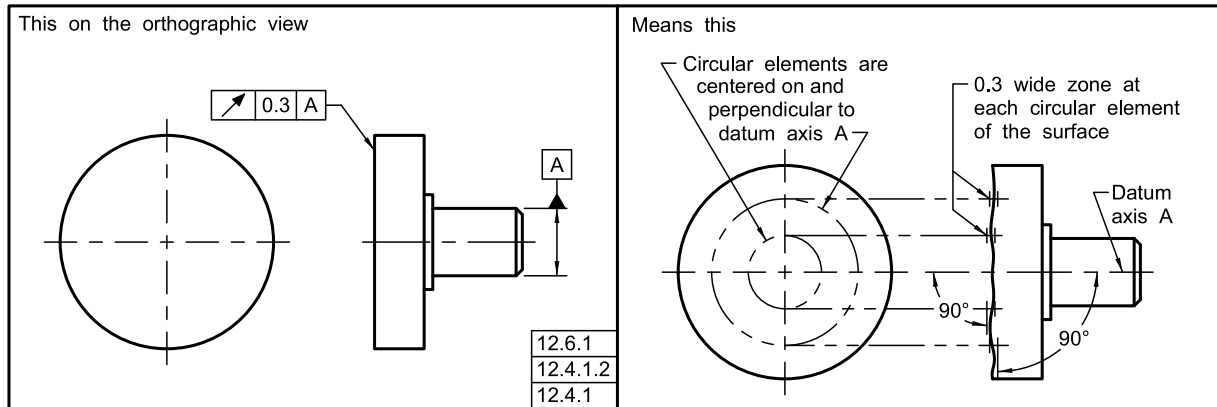
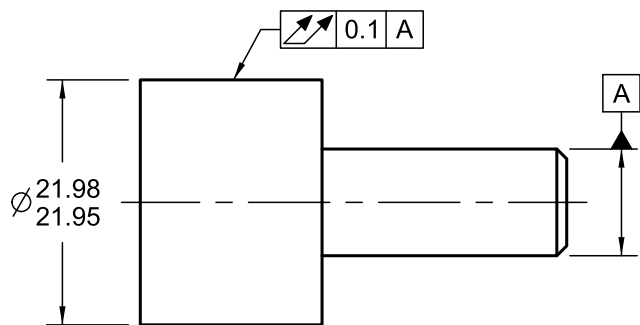
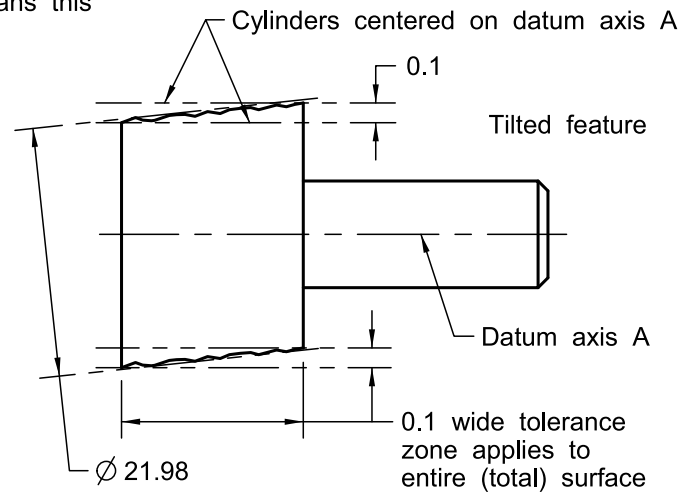

Figure 12-4 Total Runout Applied on a Cylinder and Referenced to a Datum Axis

This on the orthographic view



Means this



or this on the model

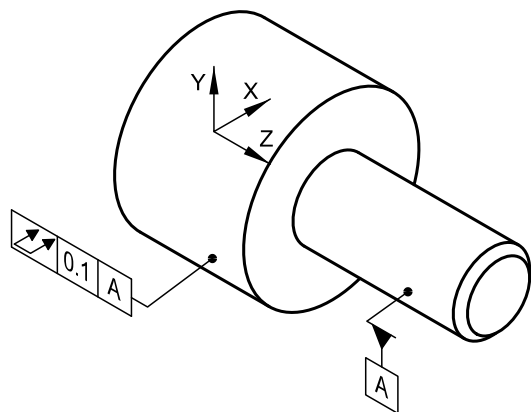

- 12.6.1
- 12.4.2.1
- 12.4.2

or means this

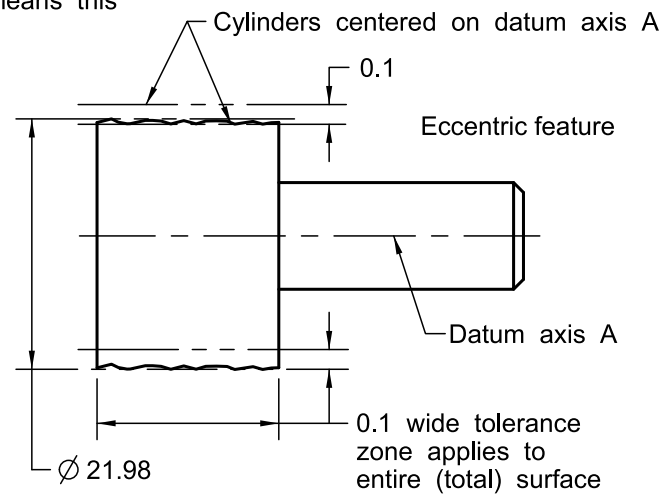

Figure 12-5 Total Runout Applied on a Face Surface and Referenced to a Datum Axis

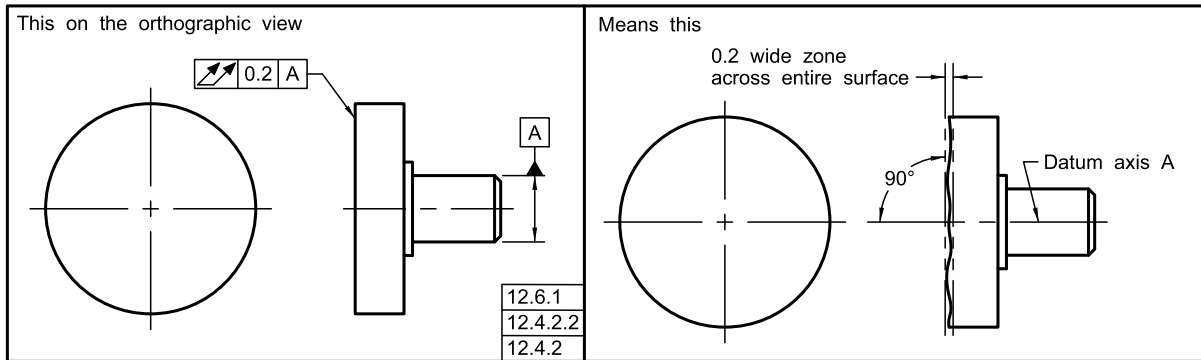
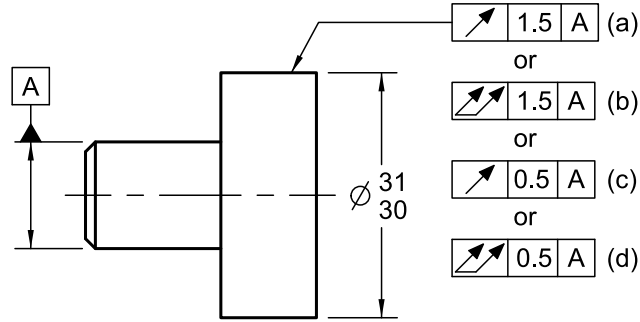

Figure 12-6 Size and Runout Tolerance Effects

This on the orthographic view



12.5

Means one of these

Condition	(a)		(b)		(c)		(d)	
	Size Tolerance	Circular Runout Tolerance	Size Tolerance	Total Runout Tolerance	Size Tolerance	Circular Runout Tolerance	Size Tolerance	Total Runout Tolerance
Location of Circular Elements		✓		✓		✓		✓
Location of Entire Surface				✓				✓
Circularity	✓		✓			✓		✓
Cylindricity	✓		✓		✓			✓
Straightness	✓		✓		✓			✓

Figure 12-7 Specifying Circular Runout Using a Large Size Tolerance and a Small Runout Tolerance

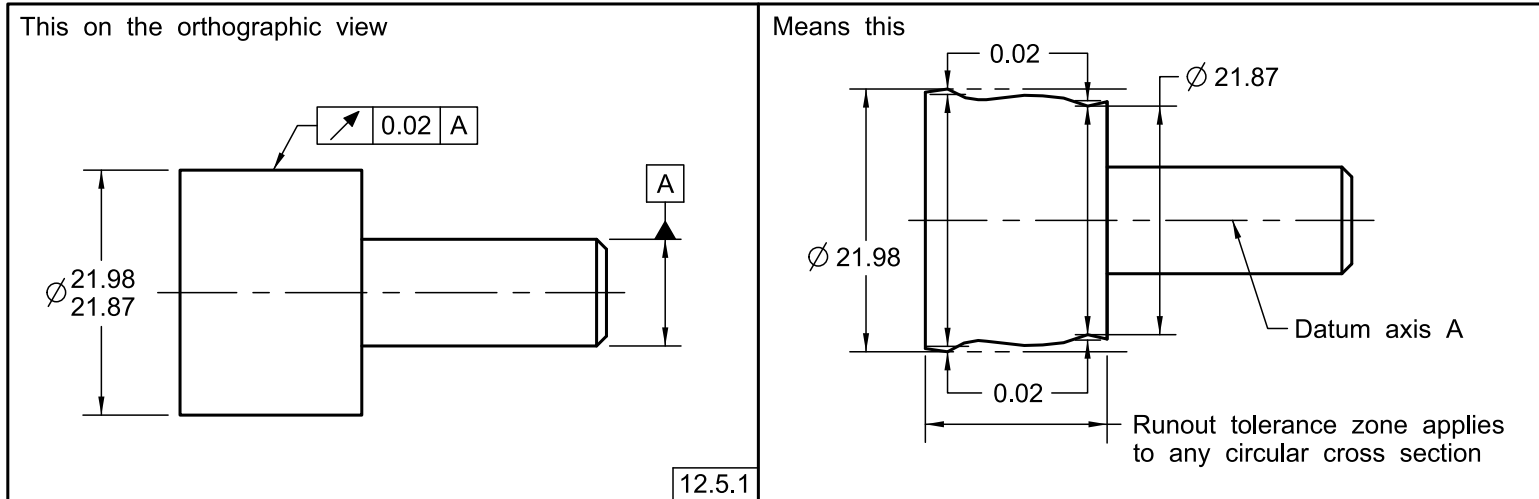

Figure 12-8 Specifying Total Runout Using a Large Size Tolerance and a Small Runout Tolerance

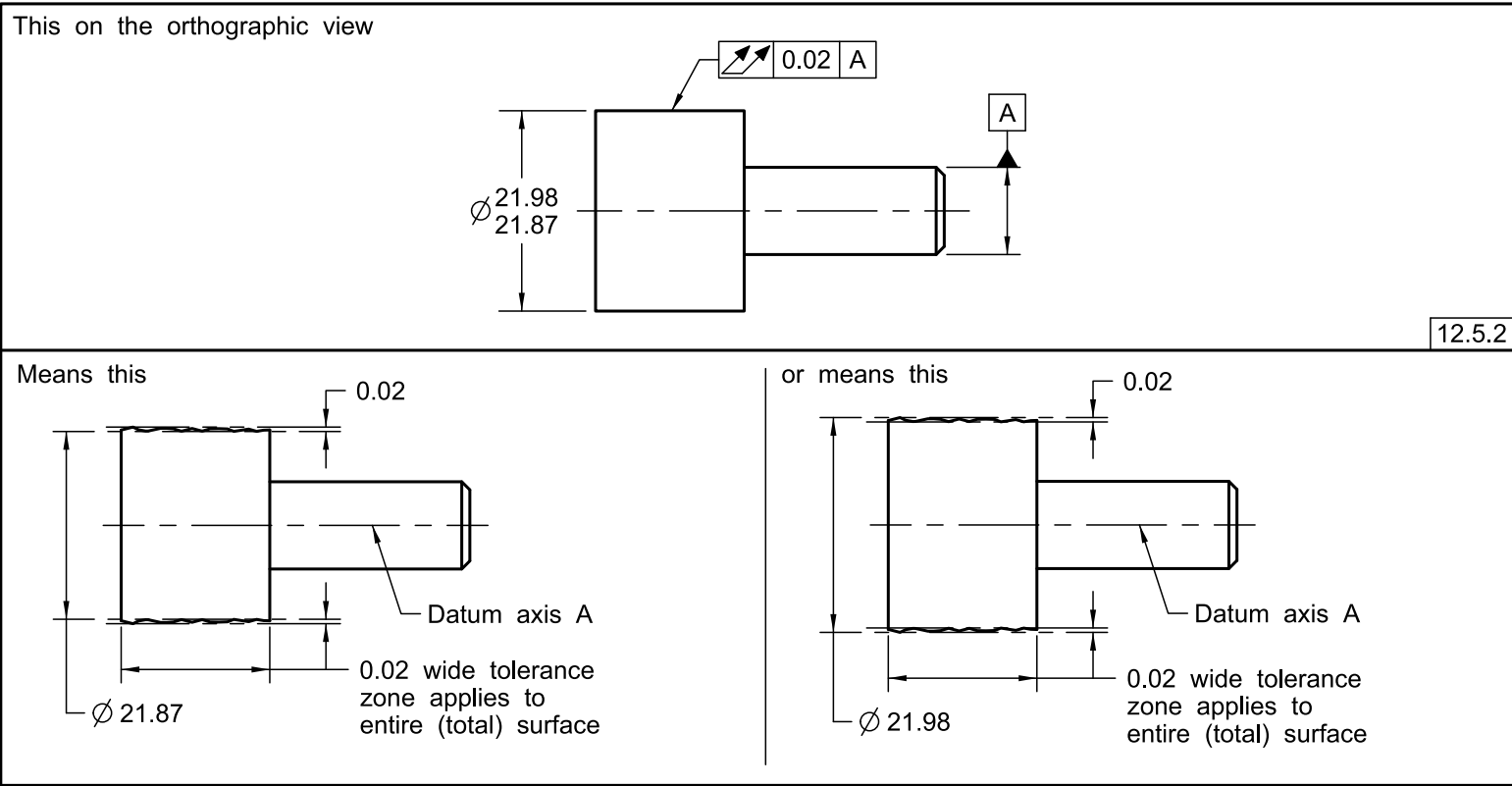

Figure 12-9 Specifying Runout Relative to Two Cylindrical Datum Features

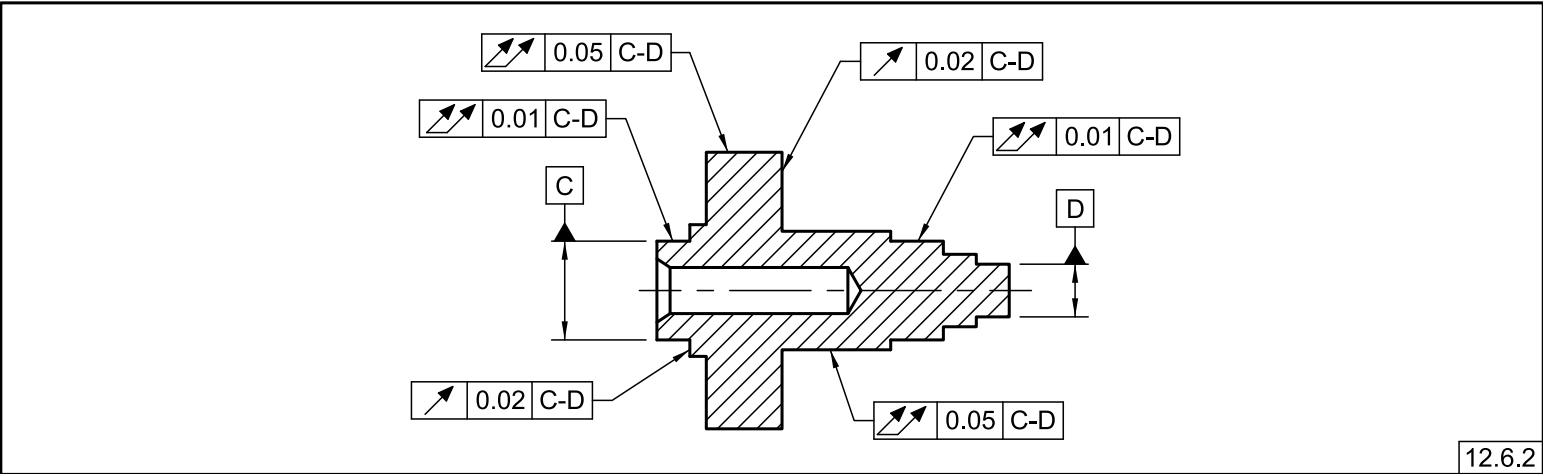

Figure 12-10 Specifying Runout to a Surface and Diameter

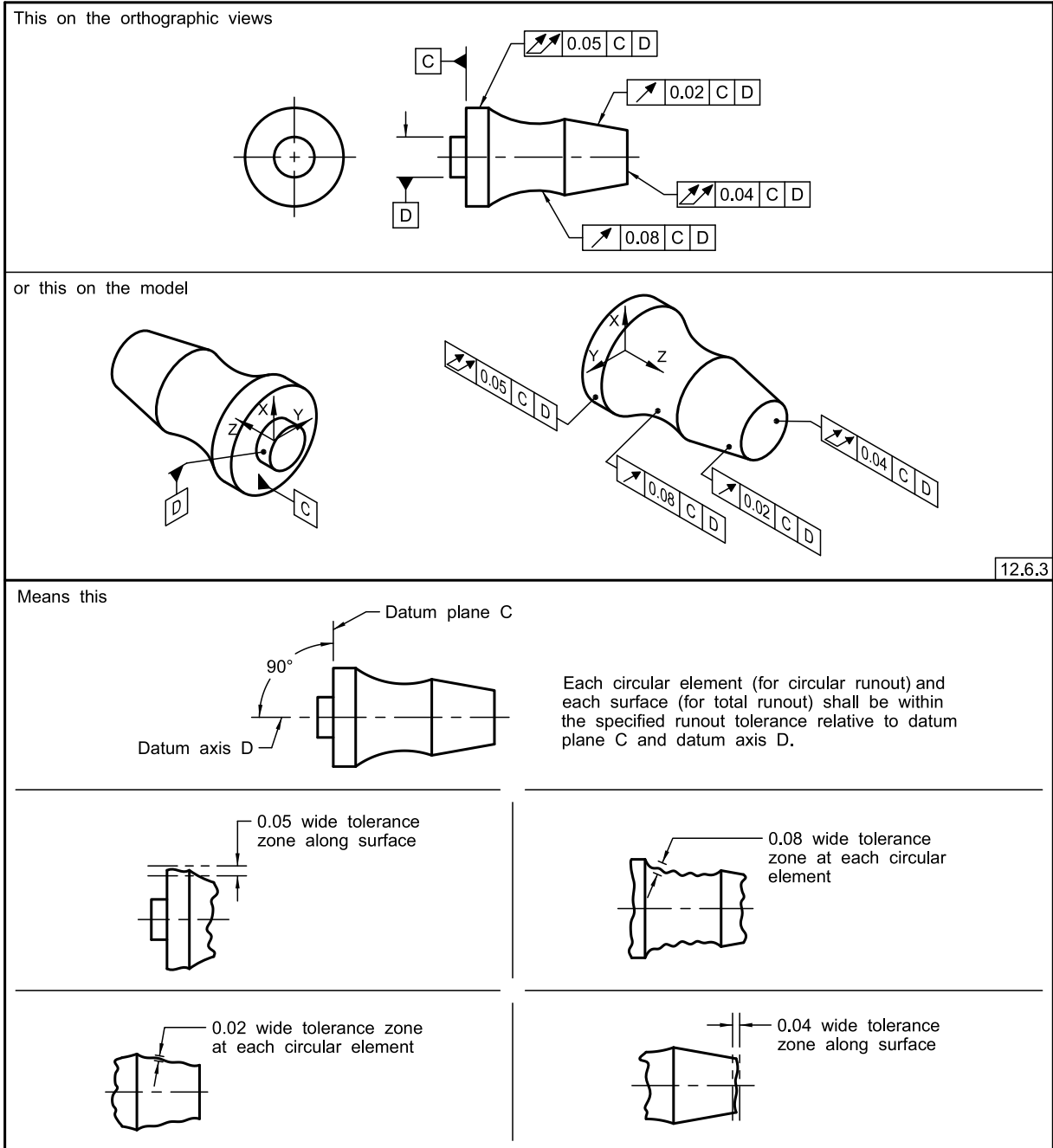
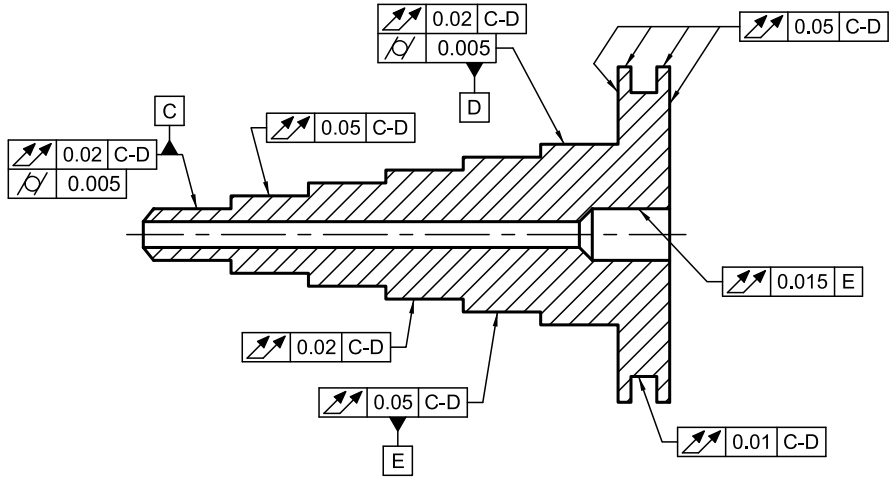
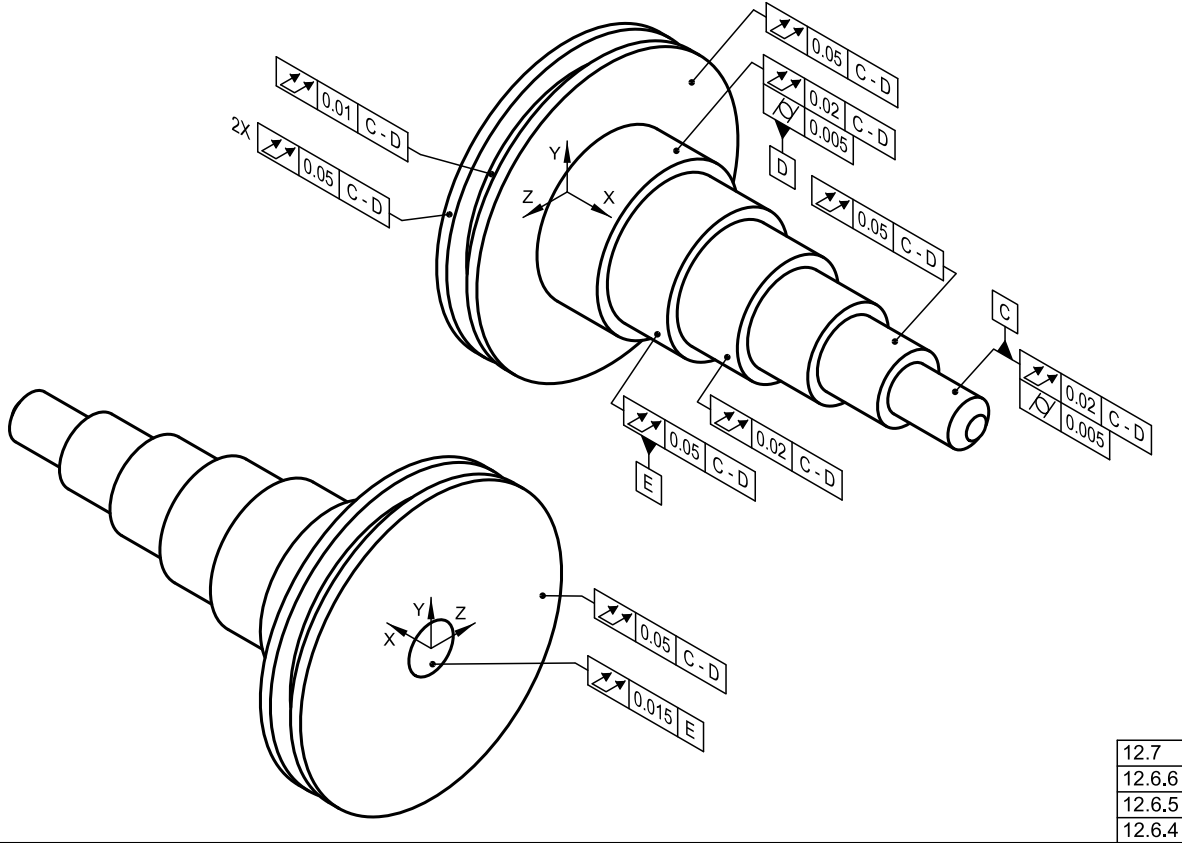

Figure 12-11 Specifying Runout Relative to Two Datum Diameters With Form Control Specified

This on the orthographic view



or this on the model



12.7
12.6.6
12.6.5
12.6.4

Figure 12-12 Specifying Runout Relative to a Surface and Diameter With Form Control Specified

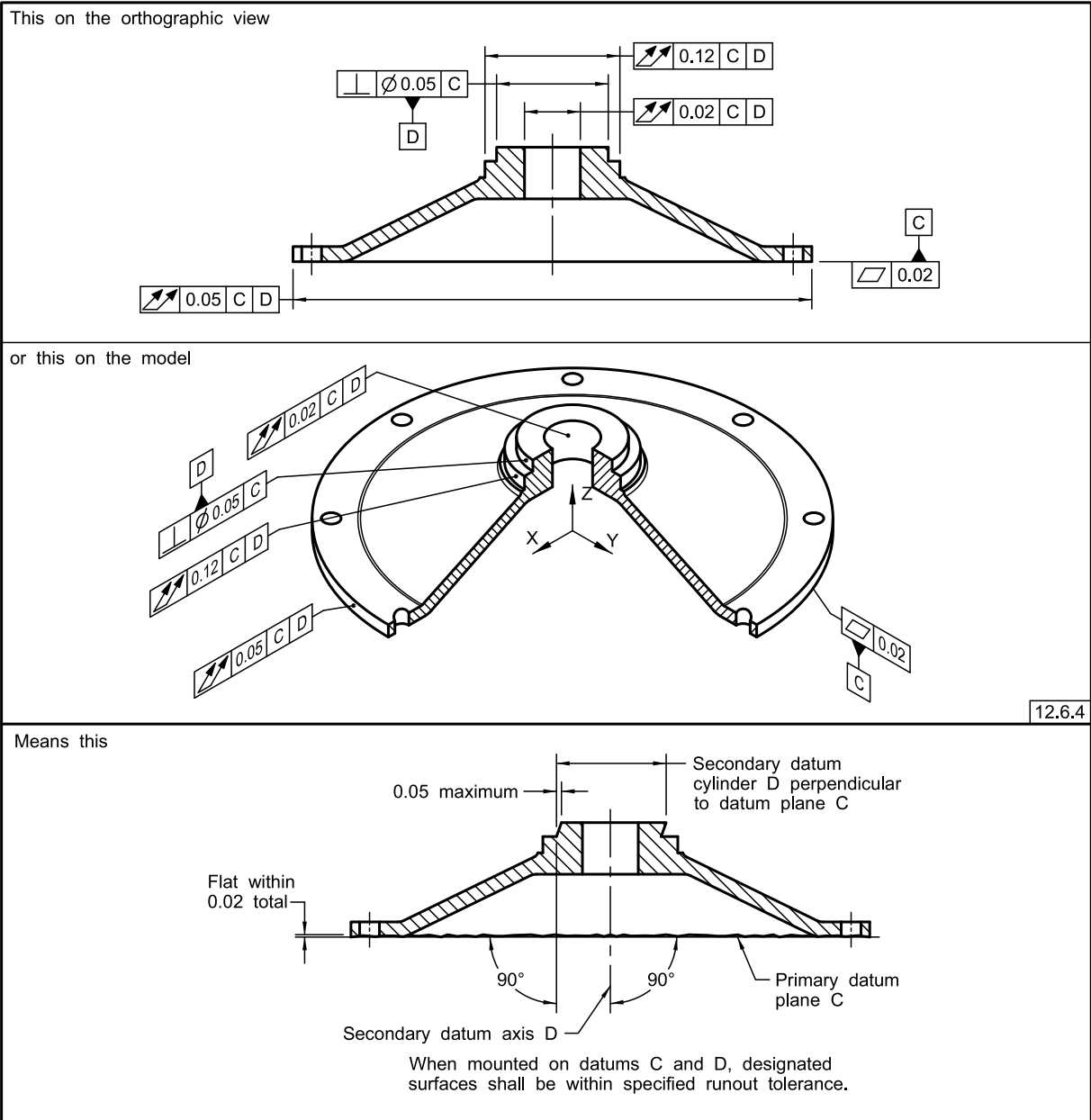

Figure 12-13 Total Runout Tolerance Applied to a Tangent Plane

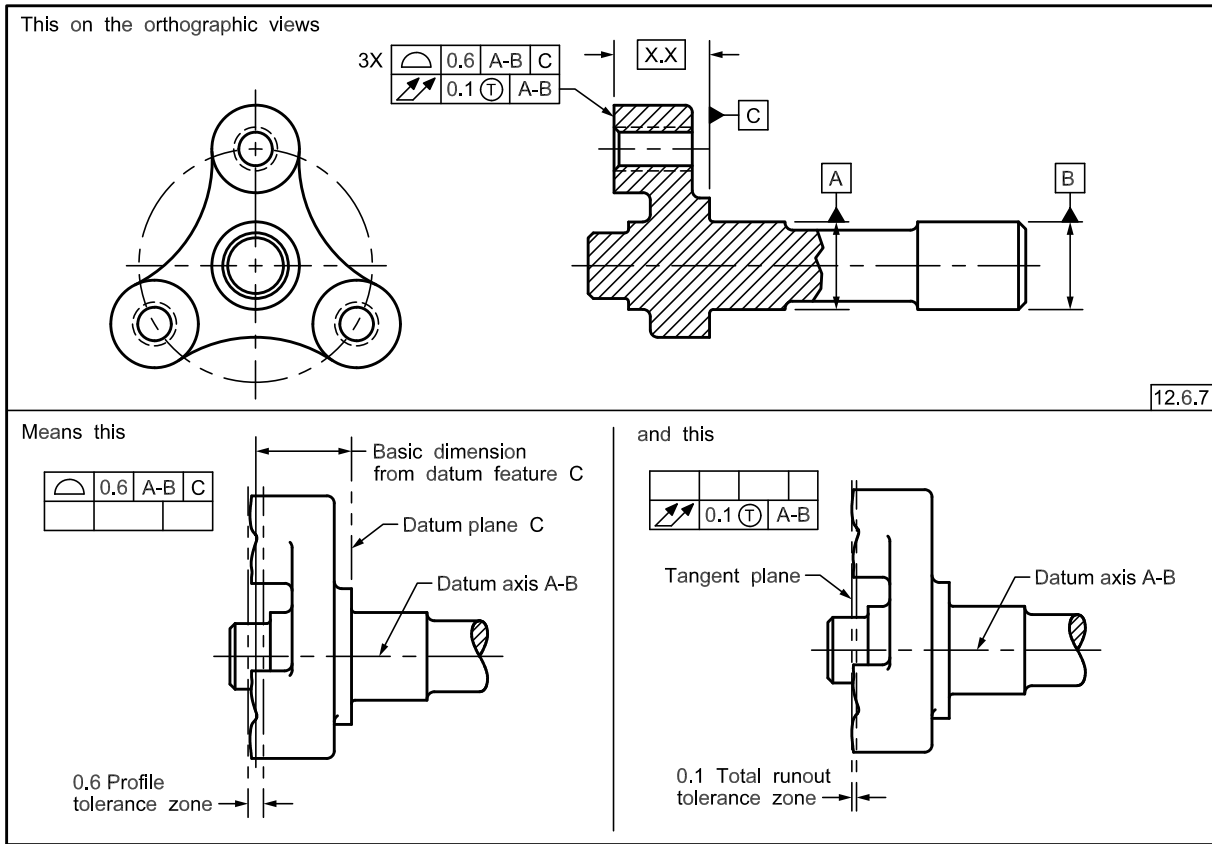

Figure 12-14 Total Runout Tolerance Applied to a Tangent Plane With Alternative Method to Establish Datum Axis

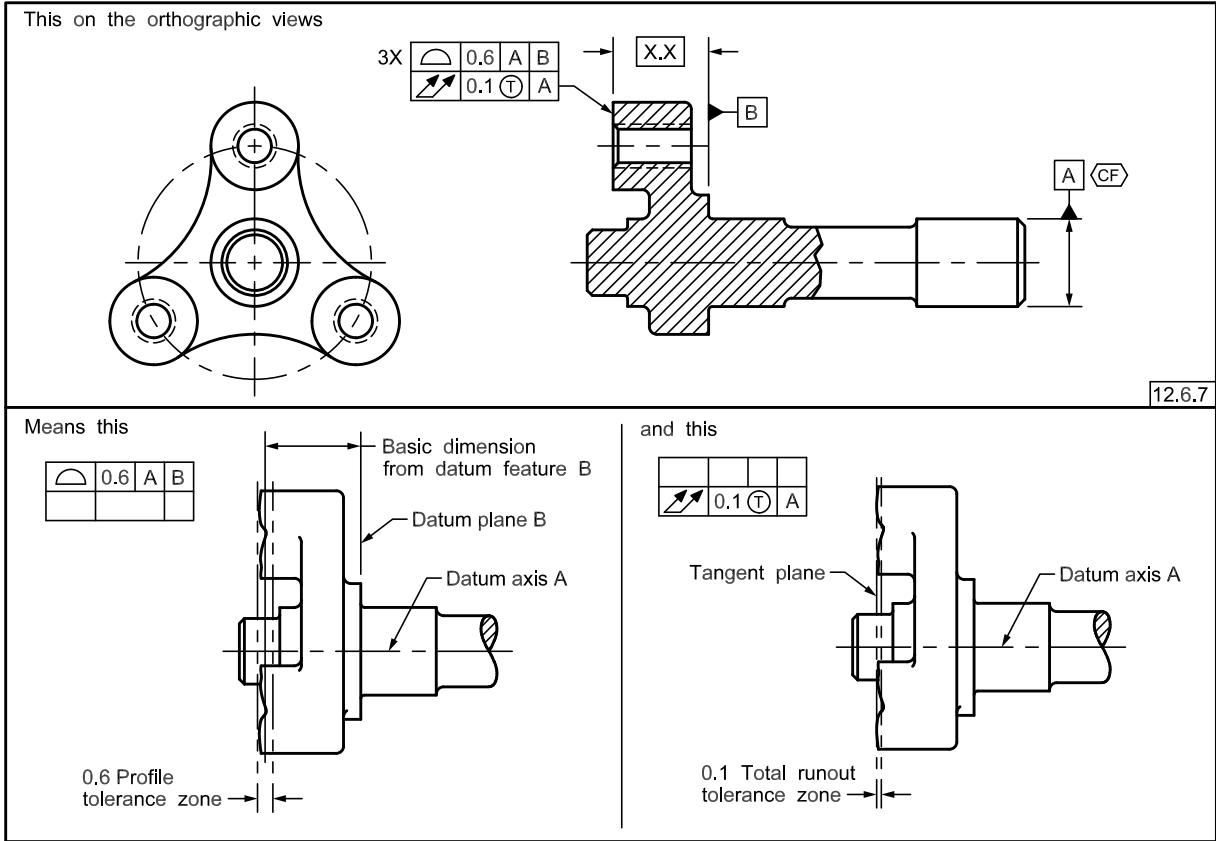
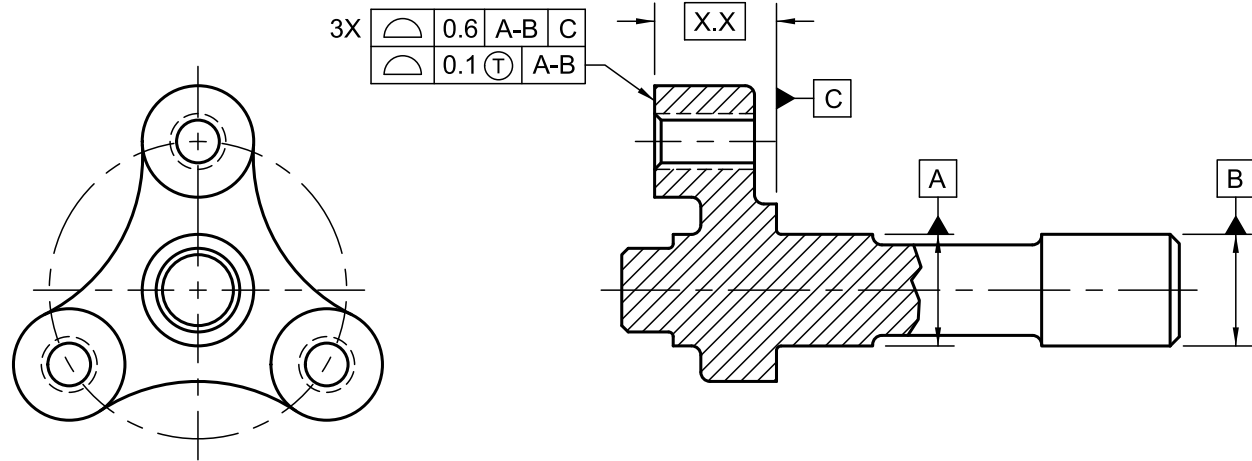

Figure 12-15 Surface Profile Tolerance Applied to a Tangent Plane

This on the orthographic views



12.6.7

Means this

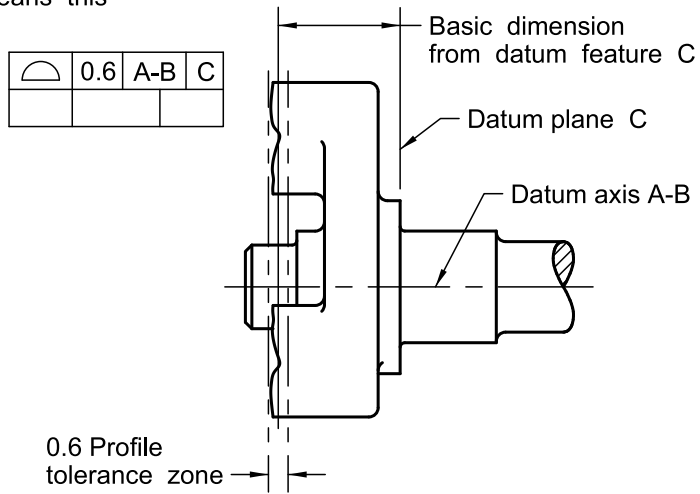

and this

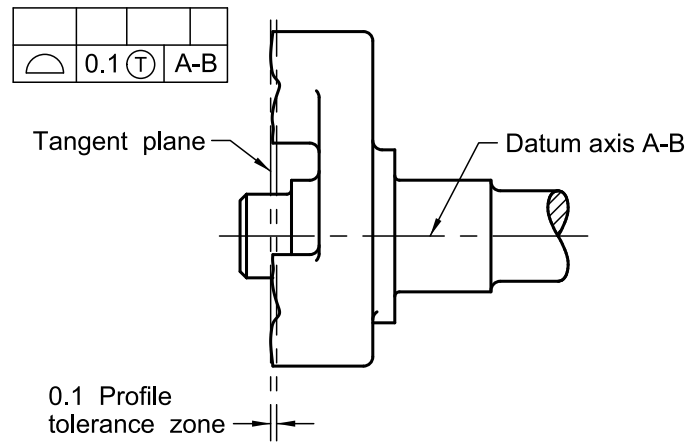
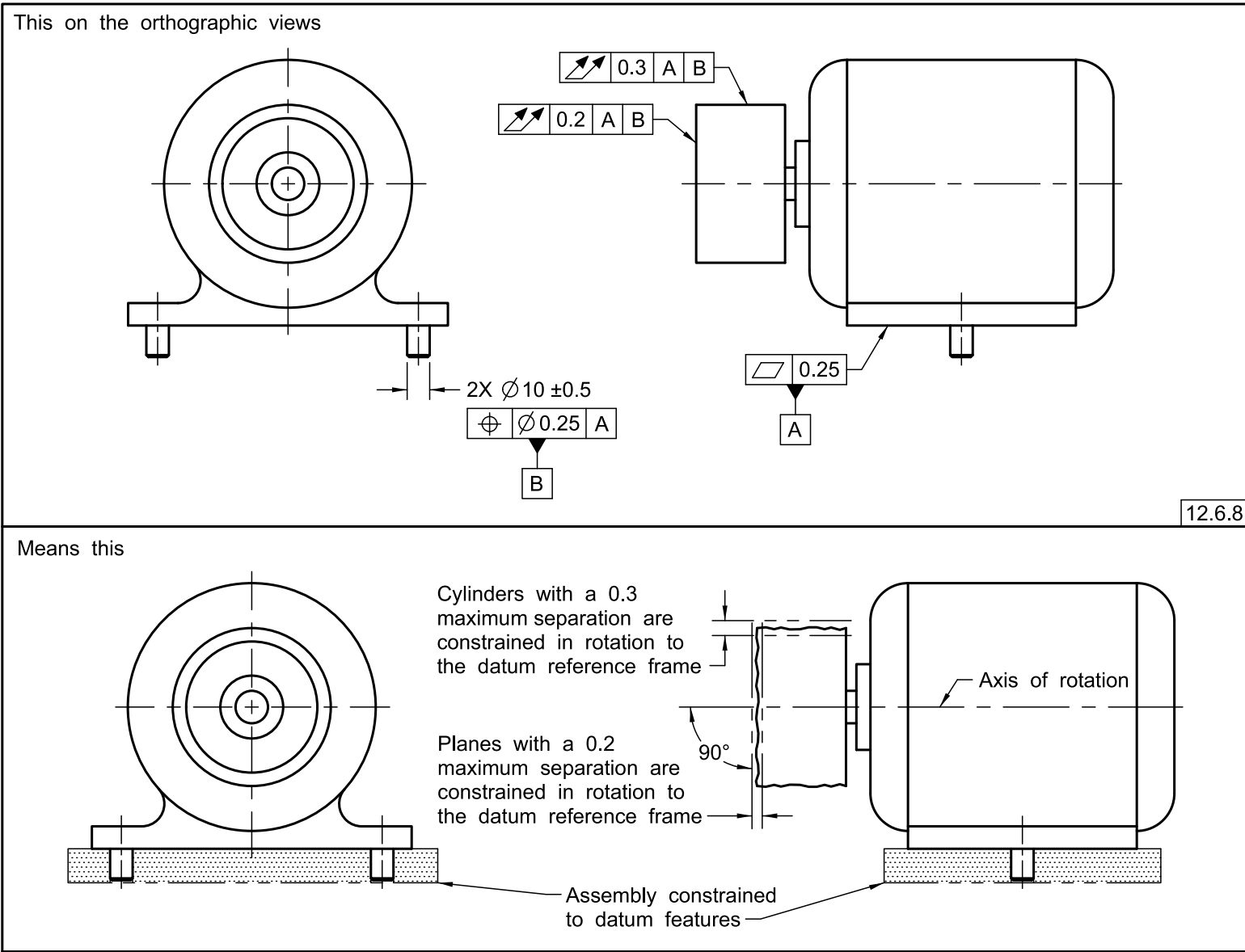

Figure 12-16 Runout Tolerance Applied on an Assembly



MANDATORY APPENDIX I

ALTERNATIVE PRACTICES

I-1 GENERAL

Although there are preferred practices shown within the body of this Standard, alternative practices may exist that are commonly used in industry. Any risks associated with using alternative practices are the responsibility of the user. Some alternative practices are documented in this Appendix as a result of common industry use or software limitations. Some practices have been removed from the body of the Standard because of their lack of a well-defined meaning. All alternative practices shown in this Appendix may be removed from this Standard after a period of time has passed to permit industry to transition to the preferred practices within the body of the Standard. Adoption of the preferred practices contained within the body of the Standard is encouraged.

I-2 DIRECTLY APPLIED LOCATION TOLERANCES

Tolerances directly applied to location dimensions for regular features of size were removed from this dimensioning and tolerancing Standard in 1982, and they are not included in the alternative practices in this Appendix. There is no defined meaning in this Standard for a tolerance that is directly applied to a location dimension that applies to a regular feature of size. See Sections 10, 11, and 12 for standard practices to be used for application of locating tolerances on regular features of size.

The preferred practice for tolerances on location of a surface is to apply a profile tolerance with appropriate datum feature references. See Section 11. An alternative practice shown in this Appendix, which was shown in previous editions of this Standard, is to directly apply tolerances on location dimensions on surfaces. The brief meaning description previously given did not go into detail about the potential for ambiguous situations caused by features manufactured with form or orientation variation. See para. I-2.1 and Figures I-1 and I-2.

As an alternative practice, a tolerance directly applied to a location dimension for a surface may be used. See Figure I-1. The explanation of the general meaning of the directly applied tolerance that was formerly given in the Standard is provided in paras. I-2.1 through I-2.3.

The application shown in Figure I-1 is sometimes used in industry, but there is an unintended and often unrecognized ambiguity. As the surfaces vary in form or orien-

tation, that variation may open questions regarding the measurement origin and measurement direction for dimensions extending between the surfaces. See Figure I-2.

I-2.1 Tolerance Accumulation From Directly Applied Tolerances

Figure I-1 compares the tolerance values resulting from three methods of dimensioning but does not address the ambiguity that can occur. Based on this simplistic understanding of the intended meaning, the dimensioning method does affect the accumulation of tolerances. However, the simplistic assessment of tolerance accumulation is incomplete, because in addition to the accumulations shown here, the effects of form and orientation on the accumulation may increase the total variation beyond what is explained.

(a) *Chain Dimensioning.* The maximum variation between two features is equal to the sum of the tolerances on the intermediate distances; this results in the greatest tolerance accumulation. In Figure I-1, illustration (a), the tolerance accumulation between surfaces X and Y is ± 0.15 .

(b) *Base Line Dimensioning.* The maximum variation between two features is equal to the sum of the tolerances on the two dimensions from their origin to the features; this results in a reduction of the tolerance accumulation. In Figure I-1, illustration (b), the tolerance accumulation between surfaces X and Y is ± 0.1 .

(c) *Direct Dimensioning.* The maximum variation between two features is controlled by the tolerance on the dimension between the features; this results in the least tolerance. In Figure I-1, illustration (c), the tolerance between surfaces X and Y is ± 0.05 .

I-2.2 Directly Applied Location Tolerance Ambiguity

When tolerance is directly applied to a location dimension between surfaces, there is no assumed origin for the measurements. When more than two surfaces are involved, questions can arise regarding whether the origin for each dimension may be different. There is ambiguity regarding the direction of the measurement when no indication is given of a required measurement vector. See Figure I-2. Whether a measurement must extend perpendicular to a particular surface or parallel to one of the

possible axes is unknown, and the feature selected to establish measurement direction can affect the measurement result if form or orientation variation exists on the features. Whether all dimensions must be measured along the same vector is not defined, and the vector may vary when different features are used as the origin for each measurement.

I-2.3 Avoidance of Location Tolerance Ambiguity

Should this alternative practice be used, the user is responsible to provide sufficient explanation of requirements to prevent the ambiguity that can occur. To avoid the risk associated with this alternative practice, apply basic location dimensions and profile tolerances.

I-3 ANGULAR RELATIONSHIPS

Angles defined with directly toleranced dimensioning may be ambiguous because assumptions must be made as to the origin. In a simple application, the use of the dimen-

sion origin symbol may be adequate. See [Section 5](#). In most cases, identifying a datum feature(s) and establishing the angular relationship with a basic angle and orientation tolerance clearly defines the orientation relationship. See [Section 9](#).

I-4 FILLETS, CORNERS, CHAMFERS, AND CONES

Fillets, corners, chamfers, and cones may be specified by notes and other common means that are not fully defined and may result in ambiguity. Tolerances for these features may be clearly defined using profile tolerancing. See [Section 11](#). Profile tolerancing may control the location, orientation, size, and form within a defined boundary. A chamfer or cone may be located by identifying a gage diameter with a positional tolerance, a combination of profile and position, or a composite profile tolerance. See [Sections 10](#) and [11](#).

Figure I-1 Tolerance Accumulation

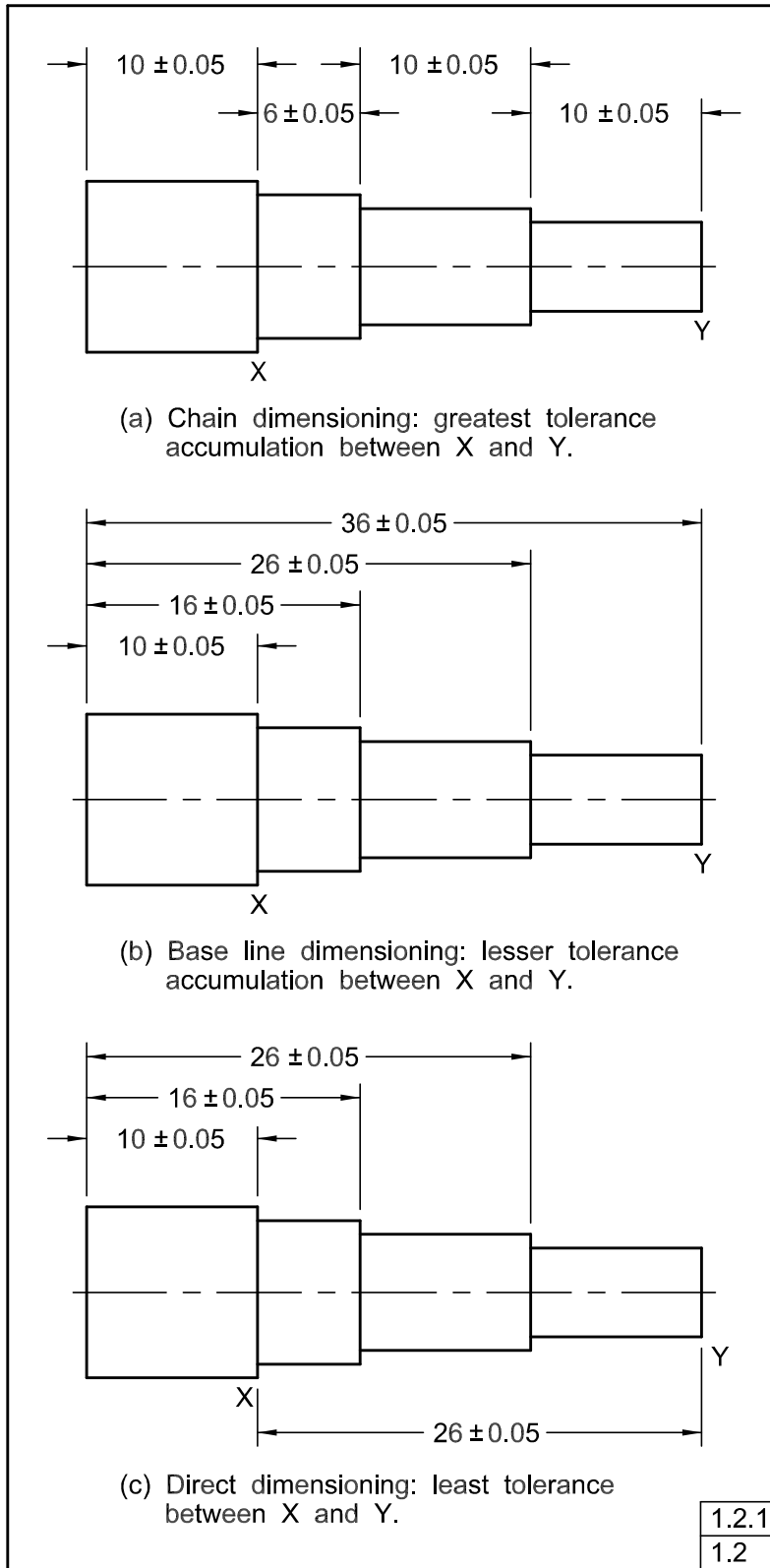
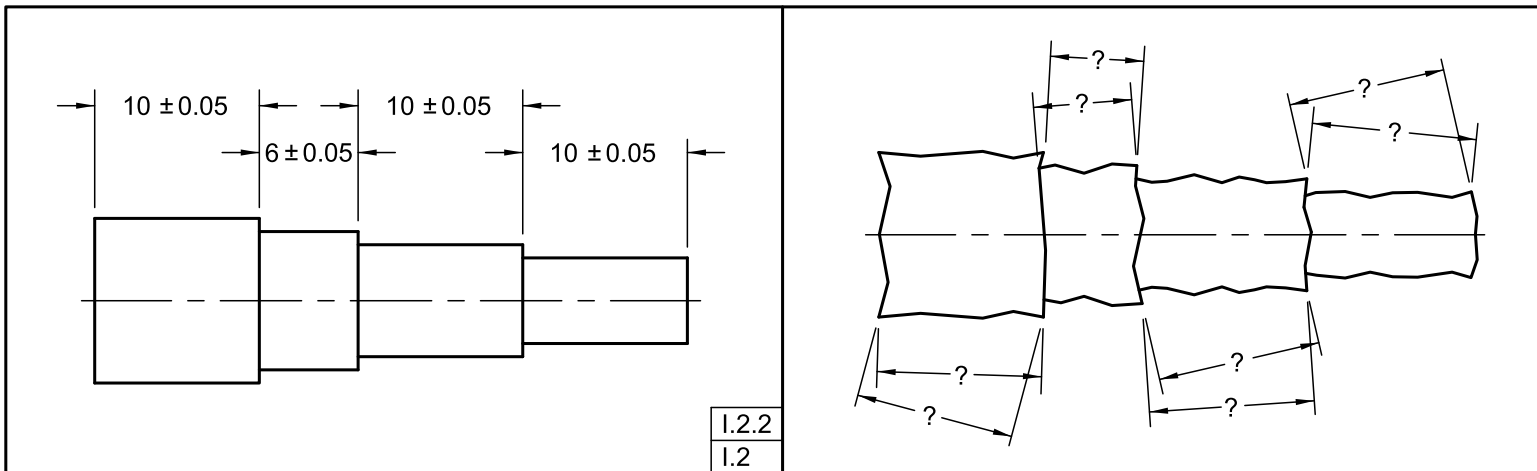

Figure I-2 Tolerance Accumulation Ambiguity



NONMANDATORY APPENDIX A

PRINCIPAL CHANGES AND IMPROVEMENTS

A-1 GENERAL

The purpose of this Appendix is to provide a list of the principal changes and improvements in this revision of the Standard. The changes specific to a Section or Appendix are summarized under the appropriate Section headings in this Appendix. This Appendix does not include an exhaustive list of all edits made in the Standard.

Figures have been updated to include model-based application of dimensions and tolerances. Views have been added to figures to illustrate application in models. Where an application method is specific to either orthographic views or models, the limitation of applicability is noted in the figure or text. For explanation of model-based application requirements that are different from orthographic view requirements, see ASME Y14.41.

A-2 STANDARD Y14 FORMAT

The format of this Standard has been revised to organize the material previously in Section 1 into new Sections 1 through 4 to be consistent with other ASME Y14 standards. This change resulted in the renumbering of all Sections but did not affect the order of information. Conventions defined in new subsection 1.4 have been applied throughout the Standard; individual edits based on those conventions are not delineated in this Appendix.

A-3 SECTION 1, SCOPE

Section 1 is now limited to the subject of Scope. Subsection 1.4 was added to explain the ASME Y14 series conventions used in the ASME Y14 standards, and these conventions have been applied throughout this Standard.

A-4 SECTION 2, REFERENCES

This Section was previously subsection 1.2.

Precedence of information in this Standard was made mandatory in the case of a conflict between this Standard and the information contained in any Standard referenced within this one.

A-5 SECTION 3, DEFINITIONS

Definitions for terms shown in ASME Y14.5-2009 were contained in subsection 1.3 and throughout the text. Definitions for terms specific to this Standard are now in Section 3.

A-5.1 Edited Definitions

The following definitions were edited for added clarity and without intent of change to the meaning: angularity; boundary, least material (LMB); datum target; feature; free state; irregular feature of size; and runout.

A-5.2 Added Definitions

The following definitions were added: continuous feature, continuous feature of size, interruption, represented line element, restrained, and true geometric counterpart.

A-5.3 Deleted Definitions

The following definitions were deleted: concentricity, free state variation, restraint, symmetry, and theoretical datum feature simulator.

A-6 SECTION 4, FUNDAMENTAL RULES AND GENERAL DIMENSIONING PRACTICES

A-6.1 Fundamental Rules Relocated

Fundamental rules previously in subsection 1.4 are now in Section 4.

A-6.2 Fundamental Rules Edited

Requirements in para. 4.1(g) were split to create requirements 4.1(g) and 4.1(h). Requirement 4.1(o) was edited to clarify applicability of the full extent requirement on tolerances and datums. Requirement 4.1(q) was added to explicitly state that UOS by drawing/model note or reference to a separate document, the as-designed dimension value does not establish a functional or manufacturing target. Requirement(s) regarding elements that are included within tolerance boundaries were added.

A-7 SECTION 5, GENERAL TOLERANCING AND RELATED PRINCIPLES

A-7.1 Section Renumbered

Section 5 was previously Section 2.

A-7.2 Directly Toleranced Location Dimensions Removed From the Body of the Standard

Information applicable to directly toleranced location dimensions for surfaces has been removed from this Section and added to [Mandatory Appendix I](#). The practice of direct application of tolerances on location dimensions is not supported as a preferred practice because of the ambiguity that can be created through this method. This practice is now included as an alternative practice in [Mandatory Appendix I](#), and some of the possible ambiguities are explained. This information has been placed in an Appendix to permit its use during a transition period as users become familiar with the preferred practices in which feature control frames are used to specify profile tolerances for the location of surfaces.

A-7.3 Rule #1 Explanation Expanded

Requirements related to Rule #1 are clarified in [para. 5.8.1\(a\)](#), and their applicability to a feature of size that has localized areas without opposed points has been added in [para. 5.8.1\(e\)](#).

A-7.4 Paragraph 5.8.2 Edited

The exceptions to Rule #1 have been edited.

A-7.5 Paragraph 5.16.1 Radius Further Explained

The effect of a radius tolerance has been edited.

A-7.6 Paragraph 5.16.2 Controlled Radius Further Explained

The effect of a controlled radius tolerance has been edited.

A-8 SECTION 6, SYMBOLOGY

A-8.1 Section Renumbered

Section 6 was previously Section 3.

A-8.2 Applicability of Symbols in Models Illustrated

Application of symbols in models was added to some figures. Notation was added where needed to indicate application limitation to orthographic views.

A-8.3 Added Symbols

A “dynamic profile tolerance zone modifier” was added for use with profile tolerancing. A “from-to” symbol was added for indicating the direction in which a tolerance or other requirement applies.

A-8.4 Removed Symbols

“Concentricity” and “symmetry” symbols have been removed.

A-8.5 “Free State” Symbol Application Revised

The explanation of the use of the “free state” symbol as defined in [para. 6.3.20](#) was revised.

A-9 SECTION 7, DATUM REFERENCE FRAMES

A-9.1 Section Renumbered

Section 7 was previously Section 4.

A-9.2 Effects of Straightness on Datum Simulation Explained

The explanation of the method to determine the MMB of a datum feature was expanded and clarified to include a straightness tolerance on the datum feature of size. [Figures 7-22](#) and [7-23](#) and [paras. 7.11.6](#) through [7.11.8](#) explain the application of MMB and LMB. [Figure 7-24](#) and [para. 7.11.9](#) were added to explain the applicability of RMB.

A-9.3 Clarified True Geometric Counterpart at LMB

An explanation for determining the size of a true geometric counterpart at LMB was clarified in [para. 7.11.8](#) and its subparagraphs.

A-9.4 Tolerance Accumulation Effects of RFS

An explanation of the accumulation of tolerances resulting from tolerances applied RFS was expanded in [para. 7.11.9](#) and its subparagraphs.

A-9.5 Simulation Requirements for Datum Features

[Paragraphs 7.11.9](#) and [7.16.7](#) were edited and [para. 7.16.8](#) was added to establish a changed requirement related to datum feature shift/displacement. These revisions require only an extremity of the simulated datum feature to remain within the MMB and LMB. That is a change from the ASME Y14.5-2009 requirement for the datum feature to remain in contact with the simulator.

A-9.6 Common Datum

In [subsection 7.12](#), the term “common datum” replaced the term “multiple datum.”

A-9.7 Datum Feature Symbol Application With a Feature Control Frame

The required method for attaching a profile feature control frame and a datum feature symbol to multiple surfaces was relocated from Section 7 to [Section 6](#).

A-9.8 Single Solution for a Datum Reference Frame

A requirement was added to [para. 7.12.4](#) for a single solution when establishing a datum reference frame.

A-9.9 Tolerances Applicable in Free State

All requirements are now applicable in the free state UOS. Restrained condition requirements and use of the “free state” symbol are explained in [subsection 7.20](#).

A-9.10 Coordinate System Association With a Datum Reference Frame

The explanation of identifying the coordinate system associated with a datum reference frame has been expanded in [subsection 7.21](#).

A-9.11 Customized Datum Reference Frame Limitation

A note was added to [subsection 7.22](#) that prohibits using a customized datum reference frame in a composite tolerance.

A-9.12 Datum Target Requirements and CAD

Application of datum target dimensional requirements and accommodation of CAD capabilities have been added in [para. 7.24.3](#).

A-10 SECTION 8, TOLERANCES OF FORM

A-10.1 Section Renumbered

[Section 8](#) was previously Section 5.

A-10.2 Combined Effects of Multiple Tolerances Applied at MMC on a Feature of Size

A default was established in [para. 8.4.1.3](#) in which form tolerances applied at MMC to a feature of size do not combine to affect the IB or OB of a position or orientation tolerance that is applied to the same feature when the tolerances are applied at MMC.

A-10.3 Cylindricity Clarification

The explanation of cylindricity was rewritten for clarity and without any intent to change cylindricity requirements.

A-10.4 “Free State” Symbol Application Removed From This Section

Paragraphs explaining the application of the “free state” symbol have been deleted from this Section and requirements redefined based on the default that all dimensions and tolerances apply in the free state UOS. See [subsection 7.20](#). The explanation of average diameter has been retained and is in [subsection 8.5](#).

A-11 SECTION 9, TOLERANCES OF ORIENTATION

A-11.1 Section Renumbered

[Section 9](#) was previously Section 6.

A-11.2 Orientation Symbols Relocated

Definitions of orientation symbols are now in [Section 6](#), Symbology.

A-11.3 Orientation of Line Elements Redefined in Profile

Orientation applicable to individual line elements with a datum reference to an axis has been deleted from this Section; the method established for this purpose is now in [Section 11](#).

A-12 SECTION 10, POSITION TOLERANCES

A-12.1 Section Renumbered

[Section 10](#) was previously Section 7.

A-12.2 Expanded Explanation of Surface Method

The default requirement for position specified at MMC to control the surface of the feature to not violate a tolerance boundary was first explicitly stated in a note in the 1994 edition and illustrated through VC boundaries as early as 1966. The 2009 edition increased emphasis of this default. This Standard continues the transition of showing tolerance meaning in terms of the surface of the feature relative to an acceptance boundary. It is now clearly stated that the surface method and the axis method may not give exactly the same results, and that for tolerances applied at MMC, the default is the surface method. Multiple figures have been edited to show the surface method, with some figures showing both the surface method and the axis method. The surface method is not applicable to tolerances applied RFS; the axis method is the only method used for tolerances applied RFS.

A-13 SECTION 11, TOLERANCES OF PROFILE**A-13.1 Section Renumbered**

Section 11 was previously Section 8.

A-13.2 Unequally Disposed Profile Specification

The use of phantom lines in orthographic views to specify unequally disposed profile tolerance zone boundaries was removed. It was an optional practice in ASME Y14.5-2009.

A-13.3 Profile All Over

All over specification within a general tolerance block has been added.

A-13.4 Profile on a Nonsize Datum Feature

An explanation of profile on nonsize datum features has been added.

A-13.5 Orientation of Line Element Using Profile

Profile of a line as a refinement is explained in [subsection 11.9](#). This explanation includes achieving orientation of a line element using a customized datum reference frame. This accomplishes the same function as previously allowed by the use of orientation of line elements.

A-13.6 Dynamic Profile Tolerance Zone

The capability to specify a dynamic profile tolerance has been added.

A-14 SECTION 12, TOLERANCES OF RUNOUT**A-14.1 Section Renumbered**

Section 12 was previously Section 9.

A-14.2 Runout on a Tangent Plane

Application of runout tolerance on a tangent plane has been added.

A-14.3 Runout Relative to an Axis of Rotation in an Assembly

Application of runout tolerance relative to an axis of rotation, where the axis may not be a datum feature in an assembly, has been added.

A-14.4 Measurement Method Not Used to Explain Tolerance Boundaries

In past editions, runout tolerances were explained in terms of a measurement method using a dial indicator. See [Figure A-1](#). For consistency in the explanation method used for other tolerances, the explanation of runout is now based on the resulting tolerance zone. The definition of runout tolerances was not changed.

A-14.5 Independence of Size and Runout Stated

Independence of the runout tolerance from the size tolerance is now stated.

A-14.6 Runout Applicable to Feature With Interruptions

It is now stated that runout may be applied to features with interruptions such as keyways.

A-14.7 Cumulative Effects of Runout

The cumulative effects of runout tolerances have been defined.

A-14.8 “Between” Symbol and Runout

The use of the “between” symbol for defining extent of application is permitted.

Figure A-1 Specifying Total Runout Relative to a Datum Diameter

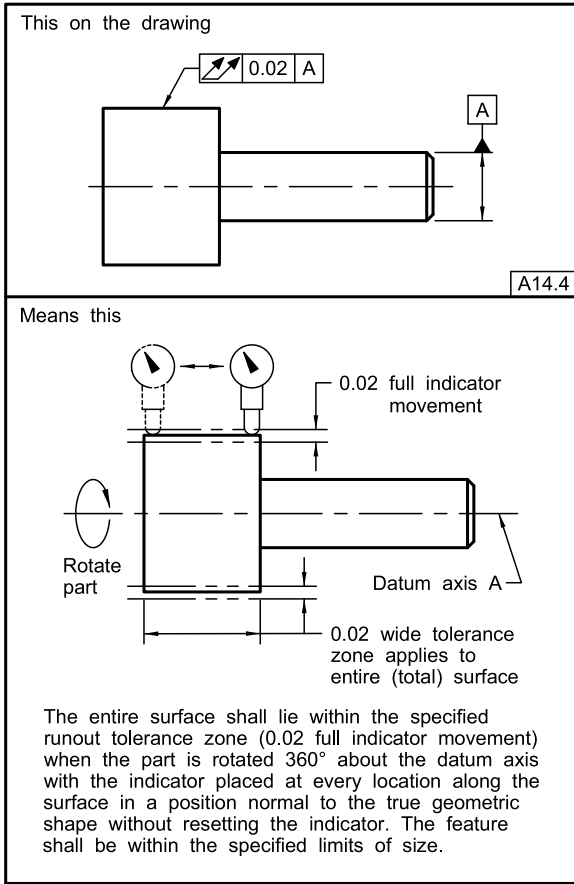

NONMANDATORY APPENDIX B

FORMULAS FOR POSITIONAL TOLERANCING

B-1 GENERAL

The purpose of this Appendix is to present formulas for determining the required positional tolerances or the required sizes of mating features to ensure that parts assemble correctly. The formulas are valid for single-segment feature control frames and feature-relating tolerances in composite tolerances applied to all types of features or patterns of features and results in a “no interference, no clearance” fit when features are at MMC with their locations in the extreme of positional tolerance. This assumes that interfacing datum features are used or that adequate control of interface features is established to prevent their adverse interaction with the tolerated hole patterns. Consideration shall be given for additional geometric conditions that could affect functions not accounted for in the formulas below.

B-2 FORMULA SYMBOLS

B-2.1 Use of Symbols

UOS, formulas given in this Appendix use the following five symbols:

D = minimum depth of thread or minimum thickness of part with restrained or fixed fastener

F = maximum diameter of fastener (MMC limit)

H = minimum diameter of clearance hole (MMC limit)

P = maximum thickness of part with clearance hole or maximum projection of fastener, such as a stud

T = positional tolerance diameter

B-2.2 Subscripts

Subscripts are used when more than one size feature or tolerance is involved.

B-3 FLOATING FASTENER CASE

When two or more parts are assembled with fasteners, such as bolts and nuts, and all parts have clearance holes for the bolts, it is termed a “floating fastener case.” See [Figure B-1](#). When the fasteners are the same diameter and it is desired to use the same clearance hole diameters and the same positional tolerances for the parts to be assembled, the following formula applies:

$$H = F + T$$

or

$$T = H - F$$

EXAMPLE: Given that the fasteners in [Figure B-1](#) are 6 diameter maximum and the clearance holes are 6.44 diameter minimum, find the required positional tolerance:

$$\begin{aligned} T &= 6.44 - 6 \\ &= 0.44 \text{ diameter for each part} \end{aligned}$$

Any number of parts with different hole sizes and positional tolerances may be mated, provided the formula $H = F + T$ or $T = H - F$ is applied to each part individually.

B-4 FIXED FASTENER CASE WHEN PROJECTED TOLERANCE ZONE IS USED

When one of the parts to be assembled has restrained fasteners, such as screws in tapped holes or studs, it is termed a “fixed fastener case.” See [Figure B-2](#). When the fasteners are the same diameter and it is desired to use the same positional tolerance in each part to be assembled, the following formula applies:

$$H = F + 2T$$

or

$$T = \frac{H - F}{2}$$

The allowable positional tolerance for each part is one-half that for the comparable floating fastener case.

EXAMPLE: Given that the fasteners in [Figure B-2](#) have a maximum diameter of 6 and the clearance holes have a minimum diameter of 6.44, find the required positional tolerance.

$$\begin{aligned} T &= \frac{6.44 - 6}{2} \\ &= 0.22 \text{ diameter for each part} \end{aligned}$$

When it is desired that the part with tapped holes have a larger positional tolerance than the part with clearance holes, the total positional tolerance of both holes ($2T$) can be separated into T_1 and T_2 in any appropriate manner so that the total equals $2T$.

$$2T = T_1 + T_2$$

EXAMPLE: When $2T$ is 0.44, if $T_1 = 0.18$, then $T_2 = 0.26$.

The general formula for the fixed fastener case where two mating parts have different positional tolerances is

$$H = F + T_1 + T_2$$

The preceding formulas do not provide sufficient clearance for the fixed fastener case when threaded holes or holes for tight-fitting members, such as dowels, are out of square. To provide for these conditions, an orientation tolerance may be applied or the projected tolerance zone method of positional tolerancing should be applied to threaded holes or tight-fitting holes. See [Section 10](#).

B-5 PROVISION FOR TILTING OF THE AXIS OR CENTER PLANE

When an orientation tolerance or the projected tolerance zone system is not used, it is required to select a positional tolerance and clearance hole combination that compensates for the allowable tilting of the axis or center plane of the fixed fastener feature.

$$H = F + T_1 + T_2 \left(1 + \frac{2P}{D} \right)$$

where

D = minimum depth of engagement of threaded or tight-fitting member

P = maximum projection of fastener

T_1 = positional tolerance diameter of clearance hole

T_2 = positional tolerance diameter of tapped or tight-fitting holes

EXAMPLE: Given that the fasteners in [Figure B-2](#) have a maximum diameter of $6F$, the positional tolerance of the clearance hole is $0.2T_1$, the positional tolerance of the tapped hole is $0.4T_2$, the maximum thickness of the plate with the clearance hole is $12P$, and the minimum thickness of the plate with the tapped hole is $8D$, find the required clearance hole size, H .

$$\begin{aligned} H &= F + T_1 + T_2 \left(1 + \frac{2P}{D} \right) \\ &= 6 + 0.2 + 0.4 \left(1 + \frac{2 \times 12}{8} \right) \\ &= 6 + 0.2 + 0.4(1 + 3) \\ &= 6 + 0.2 + 0.4(4) \\ &= 6 + 0.2 + 1.6 \\ &= 7.8 \end{aligned}$$

B-6 COAXIAL FEATURES

The formula below applies to mating parts with two coaxial features when one of these features is a datum feature for the other. See [Figure B-3](#). When it is

desired to divide the available tolerance unequally between the parts, the following formula is useful:

$$H_1 + H_2 = F_1 + F_2 + T_1 + T_2$$

NOTE: This formula is valid only for simple coaxial parts that are of similar length as shown here. Consideration shall be given for other geometric conditions (i.e., orientation, projected tolerance, etc.) that may be required for function.

EXAMPLE: Given the information shown in [Figure B-3](#), solve for T_1 and T_2 .

$$\begin{aligned} H_1 + H_2 &= F_1 + F_2 + T_1 + T_2 \\ T_1 + T_2 &= (H_1 + H_2) - (F_1 + F_2) \\ &= (20 + 10) - (19.89 + 9.92) \\ &= 0.19 \text{ total available tolerance} \end{aligned}$$

This total available tolerance may be divided in any desired manner, such as

$$T_1 = 0.12$$

$$T_2 = 0.07$$

B-7 LIMITS AND FITS

When requirements for the size and fit of mating features are specified by symbols per ANSI B4.2, the formulas for positional tolerancing are also applicable.

EXAMPLE: For a design that requires a "loose running" fit, using the "hole basis" approach, the features would be shown as follows:

$$\begin{array}{l} 20\text{H}11 \text{ in place of } 20 \begin{array}{l} +0.13 \\ 0 \end{array} \\ 20\text{c}11 \text{ in place of } 19.89 \begin{array}{l} 0 \\ -0.13 \end{array} \\ 10\text{H}11 \text{ in place of } 10 \begin{array}{l} +0.09 \\ 0 \end{array} \\ 10\text{c}11 \text{ in place of } 9.92 \begin{array}{l} 0 \\ -0.09 \end{array} \end{array}$$

The above symbols have been used with Table 2 in ANSI B4.2 to obtain the limit values shown in [Figure B-3](#). Tables B2 and B3 in ANSI B4.2 show the following:

(a) For the hole basic size 20, fundamental deviation $H_{20} = 0$.

(b) For the hole basic size 10, fundamental deviation $H_{10} = 0$.

(c) For the shaft basic size 20, fundamental deviation $c_{20} = -0.11$.

(d) For the shaft basic size 10, fundamental deviation $c_{10} = -0.08$.

Figure B-1 Floating Fasteners

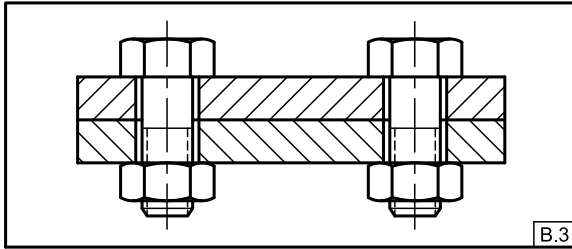

Figure B-2 Fixed Fasteners

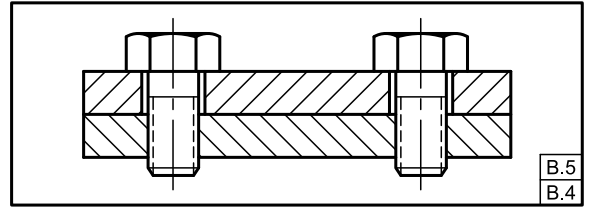
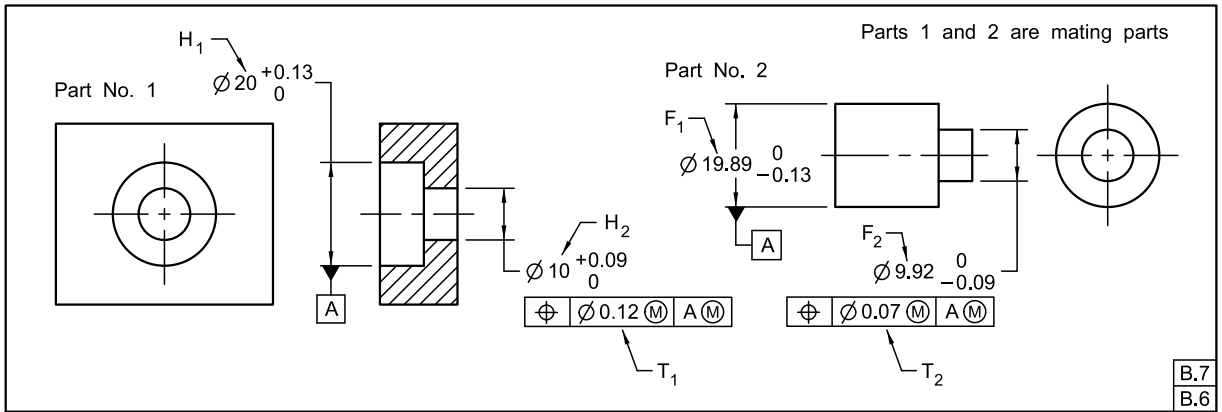

Figure B-3 Coaxial Features



NONMANDATORY APPENDIX C

FORM, PROPORTION, AND COMPARISON OF SYMBOLS

C-1 GENERAL

The purpose of this Appendix is to present the recommended form and proportion for symbols used in dimensioning and tolerancing applications and to compare ASME and ISO symbols.

C-2 FORM AND PROPORTION

Figures C-1 through C-5 illustrate the preferred form and proportion of symbols established by this Standard for use on engineering drawings. The symbols are grouped to illustrate similarities in the elements of their construction. In all figures, symbol proportions are given as a factor of h , where h is the letter height selected for use within the enclosed

symbols. See ASME Y14.2 for line weights, letter heights, and arrow proportions.

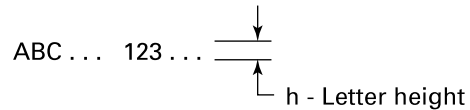

C-3 COMPARISON

Figures C-6 and C-7 provide a comparison of the symbols adopted by this Standard with those contained in international standards such as ISO 1101, ISO 129, and ISO 3040. In some instances, this Standard and the ISO standards use the same symbol, but with a different name or different meaning.

Figure C-1 Form and Proportion of Datum Symbols

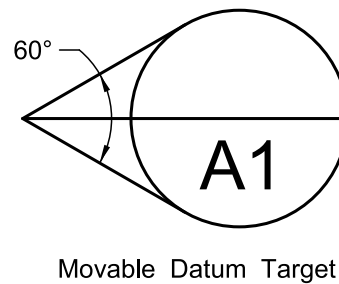
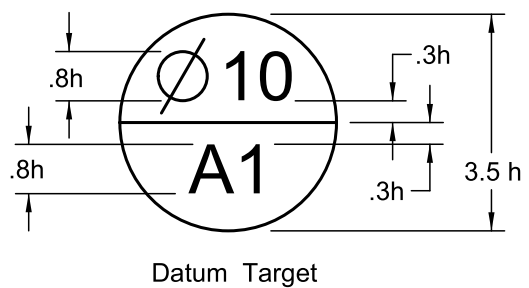
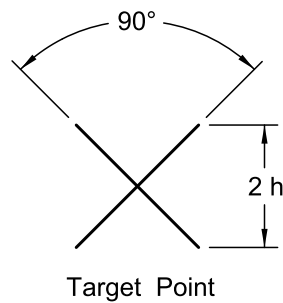
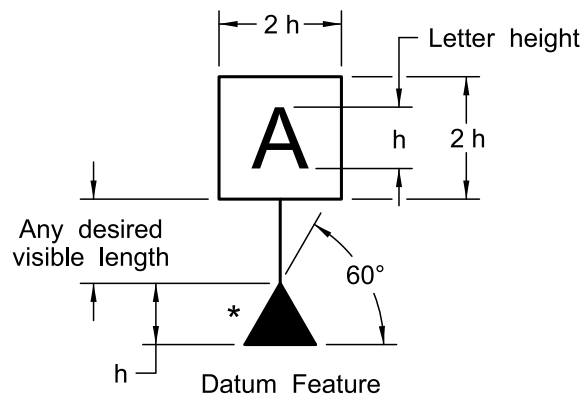

* May be filled or not filled

C.2

Figure C-2 Form and Proportion of Geometric Characteristic Symbols

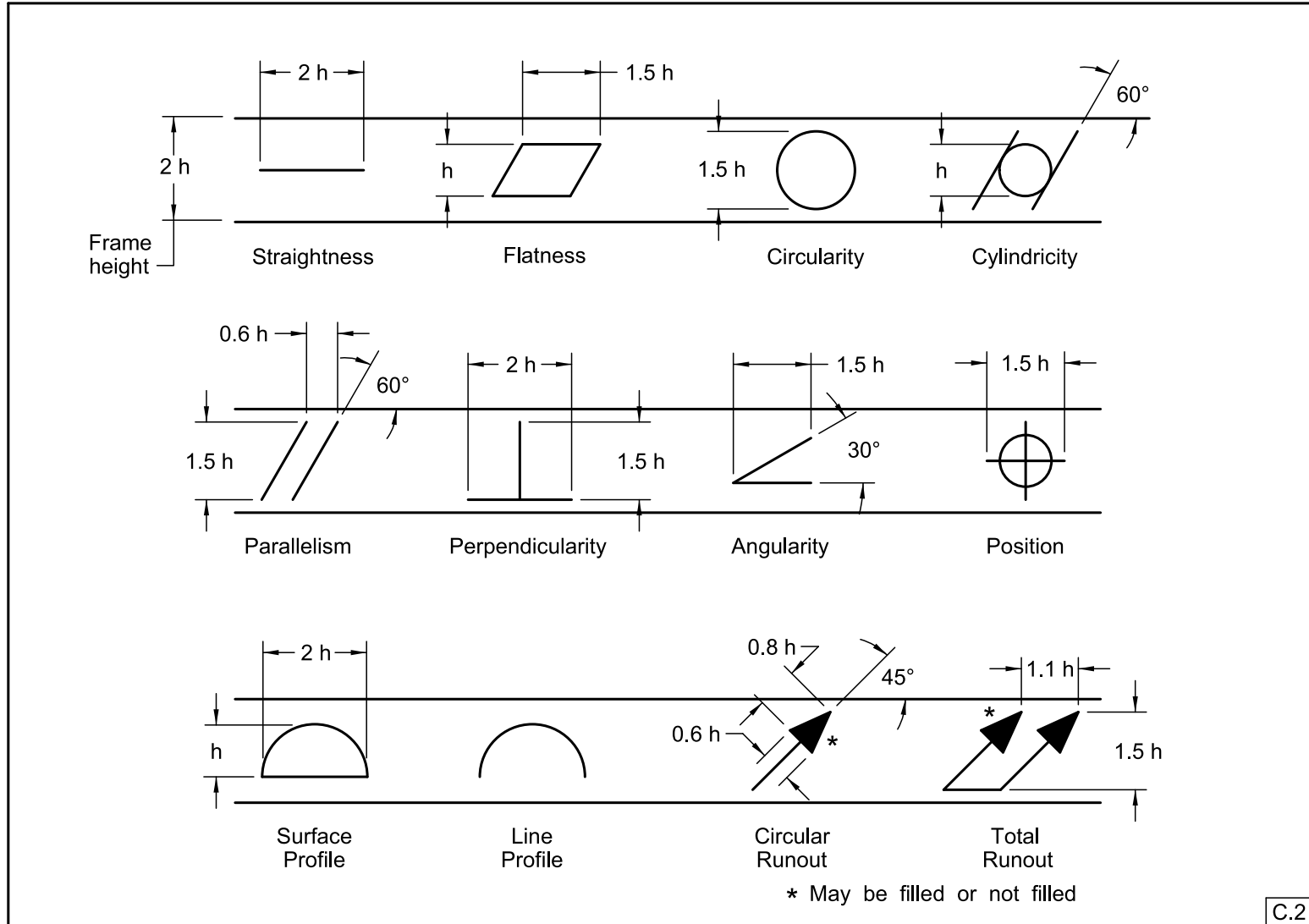

Figure C-3 Form and Proportion of Geometric Dimensioning Symbols

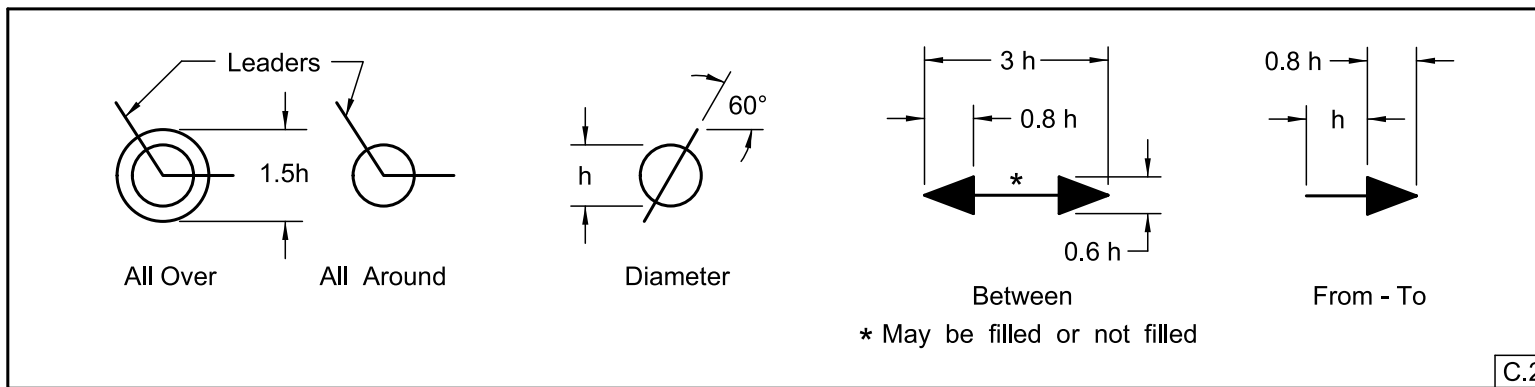

Figure C-4 Form and Proportion of Modifying Symbols

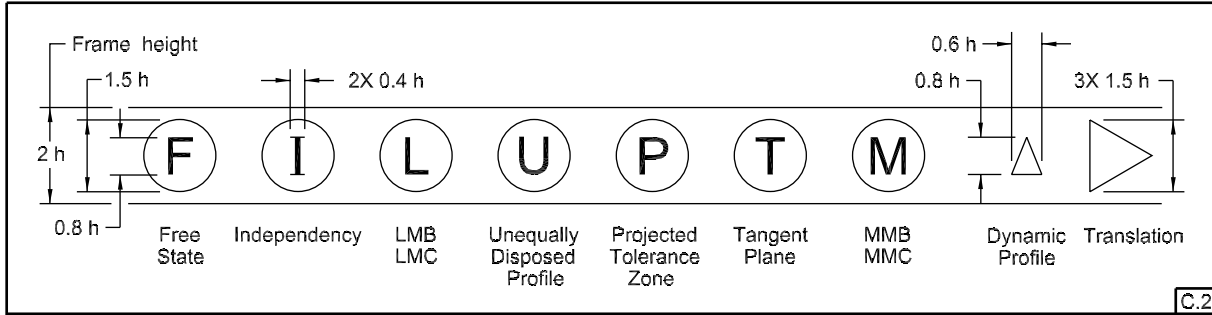

Figure C-5 Form and Proportion of Dimensioning Symbols and Letters

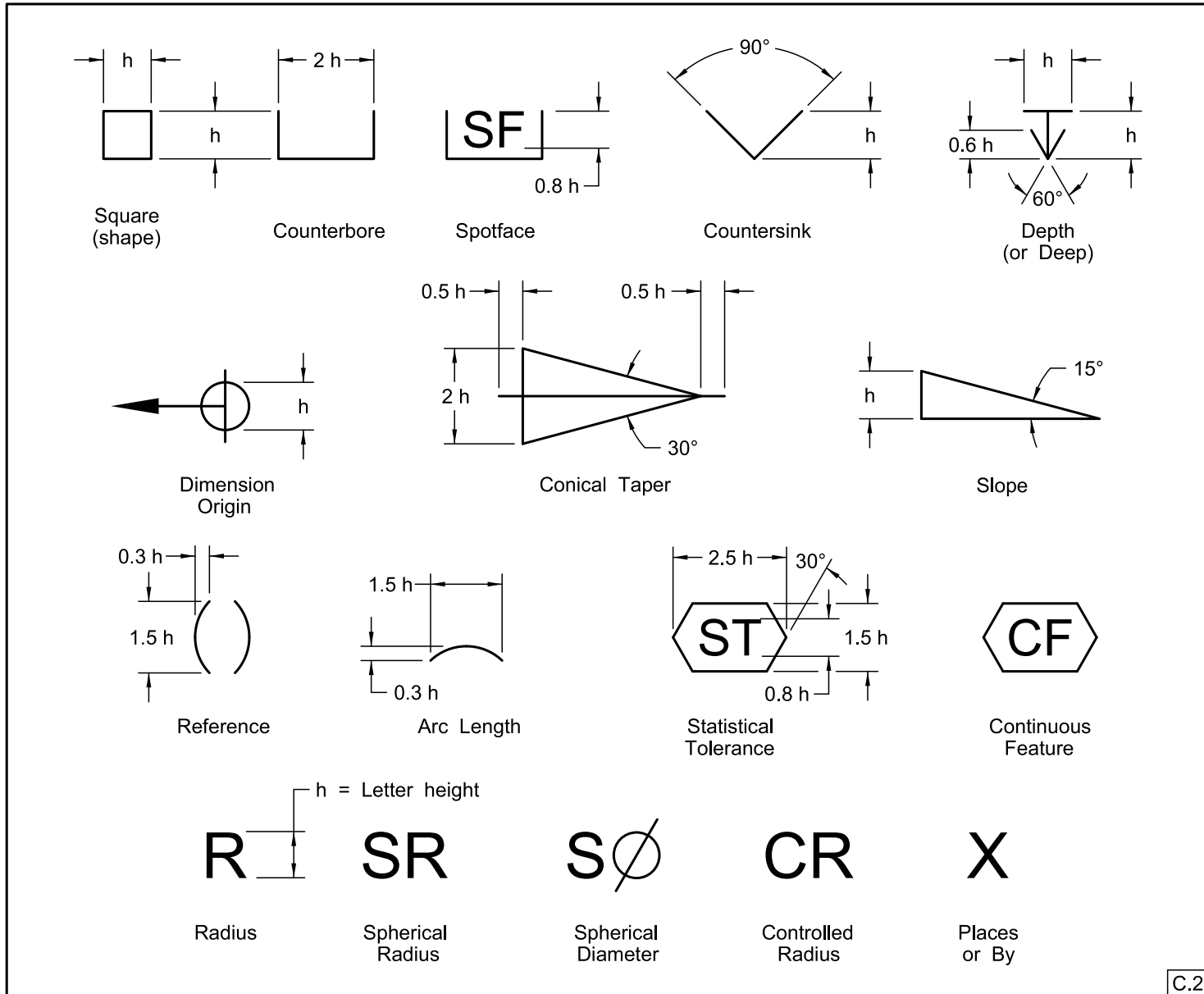

Figure C-6 Comparison of Symbols

SYMBOL FOR	ASME Y14.5	ISO
STRAIGHTNESS	—	—
FLATNESS		
CIRCULARITY		
CYLINDRICITY		
ANGULARITY		
PERPENDICULARITY		
PARALLELISM		
POSITION		
CONCENTRICITY and COAXIALITY	NONE	
SYMMETRY	NONE	
PROFILE OF A LINE		
PROFILE OF A SURFACE		
CIRCULAR RUNOUT		
TOTAL RUNOUT		
ALL AROUND		
ALL OVER		
AT MAXIMUM MATERIAL CONDITION		
AT MAXIMUM MATERIAL BOUNDARY		NONE
AT LEAST MATERIAL CONDITION		
AT LEAST MATERIAL BOUNDARY		NONE
PROJECTED TOLERANCE ZONE		
TANGENT PLANE		
FREE STATE		
UNEQUALLY DISPOSED PROFILE		UZ
ENVELOPE PRINCIPLE	DEFAULT	
INDEPENDENCY		DEFAULT
DYNAMIC PROFILE TOLERANCE		
TRANSLATION		NONE
FROM / TO		
DIAMETER	\varnothing	ϕ
BASIC DIMENSION (Theoretically Exact Dimension in ISO)		
REFERENCE DIMENSION (Auxiliary Dimension in ISO)	(50)	(50)
DATUM FEATURE		

* May be filled or not filled

C.3

Figure C-7 Comparison of Other Symbols

SYMBOL FOR	ASME Y14.5	ISO
DIMENSION ORIGIN		
FEATURE CONTROL FRAME		
CONICAL TAPER		
SLOPE		
COUNTERBORE		NONE
SPOTFACE		NONE
COUNTERSINK		NONE
DEPTH/DEEP		NONE
SQUARE		
DIMENSION NOT TO SCALE		
NUMBER OF PLACES	8X	8x
ARC LENGTH		
RADIUS	R	R
SPHERICAL RADIUS	SR	SR
SPHERICAL DIAMETER	S \varnothing	S ϕ
CONTROLLED RADIUS	CR	NONE
BETWEEN		
STATISTICAL TOLERANCE		NONE
CONTINUOUS FEATURE		NONE
DATUM TARGET		
MOVABLE DATUM TARGET		
TARGET POINT		
* May be filled or not filled		C.3

NONMANDATORY APPENDIX D FORMER PRACTICES

D-1 GENERAL

The purpose of this Appendix is to identify and illustrate symbols, terms, and methods of dimensioning that were featured in ASME Y14.5-2009. For information on changes and improvements, see [Nonmandatory Appendix A](#) and the [Foreword](#). The information in this Appendix is provided to assist in the interpretation of existing drawings on which former practices may appear.

D-2 CONCENTRICITY DEFINITION REMOVED

“Concentricity” was defined as the condition in which the median points of all diametrically opposed elements of a surface of revolution (or the median points of correspondingly located elements of two or more radially disposed features) are congruent with a datum axis (or center point).

D-3 SYMMETRY DEFINITION REMOVED

“Symmetry” was defined as the condition in which the median points of all opposed or correspondingly located elements of two or more feature surfaces are congruent with a datum axis or center plane.

D-4 CONCENTRICITY AND SYMMETRY SYMBOLS REMOVED

The symbols for concentricity and symmetry, shown below, have been deleted.

CONCENTRICITY



SYMMETRY



D-5 DECISION DIAGRAM APPENDIX REMOVED

The Nonmandatory Appendix showing decision diagrams for geometric controls has been deleted.

Y14 ENGINEERING PRODUCT DEFINITION AND RELATED DOCUMENTATION PRACTICES

Y14.1-2012	Decimal Inch Drawing Sheet Size and Format
Y14.1M-2012	Metric Drawing Sheet Size and Format
Y14.2-2014	Line Conventions and Lettering
Y14.3-2012 (R2018)	Orthographic and Pictorial Views
Y14.5-2018	Dimensioning and Tolerancing
Y14.5.1M-1994 (R2012)	Mathematical Definition of Dimensioning and Tolerancing Principles
Y14.5.2-2017	Certification of Geometric Dimensioning and Tolerancing Professionals
Y14.6-2001 (R2018)	Screw Thread Representation
Y14.8-2009 (R2014)	Castings, Forgings, and Molded Parts
Y14.24-2012	Types and Applications of Engineering Drawings
Y14.31-2014	Undimensioned Drawings
Y14.34-2013 (R2018)	Associated Lists
Y14.35-2014	Revision of Engineering Drawings and Associated Documents
Y14.36-2018	Surface Texture Symbols
Y14.37-2012	Composite Part Drawings
Y14.38-2007 (R2013)	Abbreviations and Acronyms for Use on Drawings and Related Documents
Y14.41-2012	Data Practices
Y14.43-2011	Dimensioning and Tolerancing Principles for Gages and Fixtures
Y14.44-2008 (R2014)	Reference Designations for Electrical and Electronics Parts and Equipment
Y14.47-2018	Model Organization Schema Practices
Y14.100-2017	Engineering Drawing Practices
Y32.7-1972 (R2014)	Graphic Symbols for Railroad Maps and Profiles
Y32.18-1972 (R2013)	Symbols for Mechanical and Acoustical Elements as Used in Schematic Diagrams

The ASME Publications Catalog shows a complete list of all the Standards published by the Society. For a complimentary catalog, or the latest information about our publications, call 1-800-THE-ASME (1-800-843-2763).

ASME Services

ASME is committed to developing and delivering technical information. At ASME's Customer Care, we make every effort to answer your questions and expedite your orders. Our representatives are ready to assist you in the following areas:

ASME Press	Member Services & Benefits	Public Information
<i>Codes & Standards</i>	Other ASME Programs	Self-Study Courses
Credit Card Orders	Payment Inquiries	Shipping Information
IMEchE Publications	Professional Development	Subscriptions/Journals/Magazines
Meetings & Conferences	Short Courses	Symposia Volumes
Member Dues Status	Publications	Technical Papers

How can you reach us? It's easier than ever!

There are four options for making inquiries* or placing orders. Simply mail, phone, fax, or E-mail us and a Customer Care representative will handle your request.

<i>Mail</i>	<i>Call Toll Free</i>	<i>Fax—24 hours</i>	<i>E-Mail—24 hours</i>
ASME	US & Canada: 800-THE-ASME	973-882-1717	customercare@asme.org
150 Clove Road, 6th Floor	(800-843-2763)	973-882-5155	
Little Falls, New Jersey	Mexico: 95-800-THE-ASME		
07424-2139	(95-800-843-2763)		

*Customer Care staff are not permitted to answer inquiries about the technical content of this code or standard. Information as to whether or not technical inquiries are issued to this code or standard is shown on the copyright page. All technical inquiries must be submitted in writing to the staff secretary. Additional procedures for inquiries may be listed within.

ASME Y14.5-2018

ISBN 978-0-7918-7219-2



9 780791 872192



N 00518