**Geometrical product specifications
(GPS) — ISO code system for tolerances
on linear sizes —**

Part 1:

Basis of tolerances, deviations and fits

*Spécification géométrique des produits (GPS) — Système de
codification ISO pour les tolérances sur les tailles linéaires —*

Partie 1: Base des tolérances, écarts et ajustements



PDF disclaimer

This PDF file may contain embedded typefaces. In accordance with Adobe's licensing policy, this file may be printed or viewed but shall not be edited unless the typefaces which are embedded are licensed to and installed on the computer performing the editing. In downloading this file, parties accept therein the responsibility of not infringing Adobe's licensing policy. The ISO Central Secretariat accepts no liability in this area.

Adobe is a trademark of Adobe Systems Incorporated.

Details of the software products used to create this PDF file can be found in the General Info relative to the file; the PDF-creation parameters were optimized for printing. Every care has been taken to ensure that the file is suitable for use by ISO member bodies. In the unlikely event that a problem relating to it is found, please inform the Central Secretariat at the address given below.

Licensed by ISIRI
Order # NUMBER 1059 /Downloaded: 2010-09-11
Single-user licence only, copying and networking prohibited.



COPYRIGHT PROTECTED DOCUMENT

© ISO 2010

All rights reserved. Unless otherwise specified, no part of this publication may be reproduced or utilized in any form or by any means, electronic or mechanical, including photocopying and microfilm, without permission in writing from either ISO at the address below or ISO's member body in the country of the requester.

ISO copyright office
Case postale 56 • CH-1211 Geneva 20
Tel. + 41 22 749 01 11
Fax + 41 22 749 09 47
E-mail copyright@iso.org
Web www.iso.org

Published in Switzerland

Contents

Page

Foreword	iv
Introduction.....	v
1 Scope	1
2 Normative references	1
3 Terms and definitions	1
3.1 Basic terminology	2
3.2 Terminology related to tolerances and deviations	2
3.3 Terminology related to fits	5
3.4 Terminology related to the ISO fit system	9
4 ISO code system for tolerances on linear sizes	11
4.1 Basic concepts and designations	11
4.2 Designation of the tolerance class (writing rules)	13
4.3 Determination of the limit deviations (reading rules)	14
4.4 Selection of tolerance classes	26
5 ISO fit system.....	26
5.1 General	26
5.2 Generics of fits	27
5.3 Determination of a fit.....	27
Annex A (informative) Further information about the ISO system of limits and fits and former practice	29
Annex B (informative) Examples of the use of ISO 286-1 to determine fits and tolerance classes	31
Annex C (informative) Relationship to the GPS matrix model	36
Bibliography.....	38

Foreword

ISO (the International Organization for Standardization) is a worldwide federation of national standards bodies (ISO member bodies). The work of preparing International Standards is normally carried out through ISO technical committees. Each member body interested in a subject for which a technical committee has been established has the right to be represented on that committee. International organizations, governmental and non-governmental, in liaison with ISO, also take part in the work. ISO collaborates closely with the International Electrotechnical Commission (IEC) on all matters of electrotechnical standardization.

International Standards are drafted in accordance with the rules given in the ISO/IEC Directives, Part 2.

The main task of technical committees is to prepare International Standards. Draft International Standards adopted by the technical committees are circulated to the member bodies for voting. Publication as an International Standard requires approval by at least 75 % of the member bodies casting a vote.

Attention is drawn to the possibility that some of the elements of this document may be the subject of patent rights. ISO shall not be held responsible for identifying any or all such patent rights.

ISO 286-1 was prepared by Technical Committee ISO/TC 213, *Dimensional and geometrical product specifications and verification*.

This second edition of ISO 286-1 cancels and replaces ISO 286-1:1988 and ISO 1829:1975, which have been technically revised.

ISO 286 consists of the following parts, under the general title *Geometrical product specifications (GPS) — ISO code system for tolerances on linear sizes*:

- *Part 1: Basis of tolerances, deviations and fits*
- *Part 2: Tables of standard tolerance grades and limit deviations for holes and shafts*

Introduction

This International Standard is a geometrical product specification (GPS) standard and is to be regarded as a general GPS standard (see ISO/TR 14638). It influences chain links 1 and 2 of the chain of standards on size in the general GPS matrix.

For more detailed information on the relation of this part of ISO 286 to the GPS matrix model, see Annex C.

The need for limits and fits for machined workpieces was brought about mainly by the requirement for interchange ability between mass produced parts and the inherent inaccuracy of manufacturing methods, coupled with the fact that “exactness” of size was found to be unnecessary for the most workpiece features. In order that fit function could be satisfied, it was found sufficient to manufacture a given workpiece so that its size lay within two permissible limits, i.e. a tolerance, this being the variation in size acceptable in manufacture while ensuring the functional fit requirements of the product.

Similarly, where a specific fit condition is required between mating features of two different workpieces, it is necessary to ascribe an allowance, either positive or negative, to the nominal size to achieve the required clearance or interference. This part of ISO 286 gives the internationally accepted code system for tolerances on linear sizes. It provides a system of tolerances and deviations suitable for two features of size types: “cylinder” and “two parallel opposite surfaces”. The main intention of this code system is the fulfilment of the function fit.

The terms “hole”, “shaft” and “diameter” are used to designate features of size type cylinder (e.g. for the tolerancing of diameter of a hole or shaft). For simplicity, they are also used for two parallel opposite surfaces (e.g. for the tolerancing of thickness of a key or width of a slot).

The pre-condition for the application of the ISO code system for tolerances on linear sizes for the features forming a fit is that the nominal sizes of the hole and the shaft are identical.

The previous edition of ISO 286-1 (published in 1988) had the envelope criterion as the default association criterion for the size of a feature of size; however, ISO 14405-1 changes this default association criterion to the two-point size criterion. This means that form is no longer controlled by the default specification of size.

In many cases, the diameter tolerances according to this part of ISO 286 are not sufficient for an effective control of the intended function of the fit. The envelope criterion according to ISO 14405-1 may be required. In addition, the use of geometrical form tolerances and surface texture requirements may improve the control of the intended function.

Geometrical product specifications (GPS) — ISO code system for tolerances on linear sizes —

Part 1: Basis of tolerances, deviations and fits

1 Scope

This part of ISO 286 establishes the ISO code system for tolerances to be used for linear sizes of features of the following types:

- a) cylinder;
- b) two parallel opposite surfaces.

It defines the basic concepts and the related terminology for this code system. It provides a standardized selection of tolerance classes for general purposes from amongst the numerous possibilities.

Additionally, it defines the basic terminology for fits between two features of size without constraints of orientation and location and explains the principles of “basic hole” and “basic shaft”.

2 Normative references

The following referenced documents are indispensable for the application of this document. For dated references, only the edition cited applies. For undated references, the latest edition of the referenced document (including any amendments) applies.

ISO 286-2¹⁾, *Geometrical product specifications (GPS) — ISO code system for tolerances on linear sizes — Part 2: Tables of standard tolerance grades and limit deviations for holes and shafts*

ISO 14405-1, *Geometrical product specifications (GPS) — Dimensional tolerancing — Part 1: Linear sizes*

ISO 14660-1:1999, *Geometrical Product Specifications (GPS) — Geometrical features — Part 1: General terms and definitions*

ISO 14660-2:1999, *Geometrical Product Specifications (GPS) — Geometrical features — Part 2: Extracted median line of a cylinder and a cone, extracted median surface, local size of an extracted feature*

3 Terms and definitions

For the purposes of this document, the terms and definitions given in ISO 14405-1 and ISO 14660-1 and the following apply. It should be noted, however, that some of the terms are defined in a more restricted sense than in common usage.

1) To be published. (Revision of ISO 286-2:1988)

3.1 Basic terminology

3.1.1

feature of size

geometrical shape defined by a linear or angular dimension which is a size

[ISO 14660-1:1999, definition 2.2]

NOTE 1 The feature of size can be a cylinder, a sphere, two parallel opposite surfaces.

NOTE 2 In former editions of international standards, such as ISO 286-1 and ISO/R 1938, the meanings of the terms “plain workpiece” and “single features” are close to that of “feature of size”.

NOTE 3 For the purpose of ISO 286, only features of size type cylinder as well as type-two parallel opposite surfaces, defined by a linear dimension, apply.

3.1.2

nominal integral feature

theoretically exact integral feature as defined by a technical drawing or by other means

[ISO 14660-1:1999, definition 2.3]

3.1.3

hole

internal feature of size of a workpiece, including internal features of size which are not cylindrical

NOTE See also Introduction.

3.1.4

basic hole

hole chosen as a basis for a hole-basis fit system

NOTE 1 See also 3.4.1.1.

NOTE 2 For the purpose of the ISO code system, a basic hole is a hole for which the lower limit deviation is zero.

3.1.5

shaft

external feature of size of a workpiece, including external features of size which are not cylindrical

NOTE See also Introduction.

3.1.6

basic shaft

shaft chosen as a basis for a shaft-basis fit system

NOTE 1 See also 3.4.1.2.

NOTE 2 For the purposes of the ISO code system, a basic shaft is a shaft for which the upper limit deviation is zero.

3.2 Terminology related to tolerances and deviations

3.2.1

nominal size

size of a feature of perfect form as defined by the drawing specification

See Figure 1.

NOTE 1 Nominal size is used for the location of the limits of size by the application of the upper and lower limit deviations.

NOTE 2 In former times, this was referred to as “basic size”.

3.2.2**actual size**

size of the associated integral feature

NOTE 1 “Associated integral feature” is defined in ISO 14660-1:1999, 2.6.

NOTE 2 The actual size is obtained by measurement.

3.2.3**limits of size**

extreme permissible sizes of a feature of size

NOTE To fulfil the requirement, the actual size shall lie between the upper and lower limits of size; the limits of size are also included.

3.2.3.1**upper limit of size****ULS**

largest permissible size of a feature of size

See Figure 1.

3.2.3.2**lower limit of size****LLS**

smallest permissible size of a feature of size

See Figure 1.

3.2.4**deviation**

value minus its reference value

NOTE For size deviations, the reference value is the nominal size and the value is the actual size.

3.2.5**limit deviation**

upper limit deviation or lower limit deviation from nominal size

3.2.5.1**upper limit deviation**

ES (to be used for internal features of size)

es (to be used for external features of size)

upper limit of size minus nominal size

See Figure 1.

NOTE Upper limit deviation is a signed value and may be negative, zero or positive.

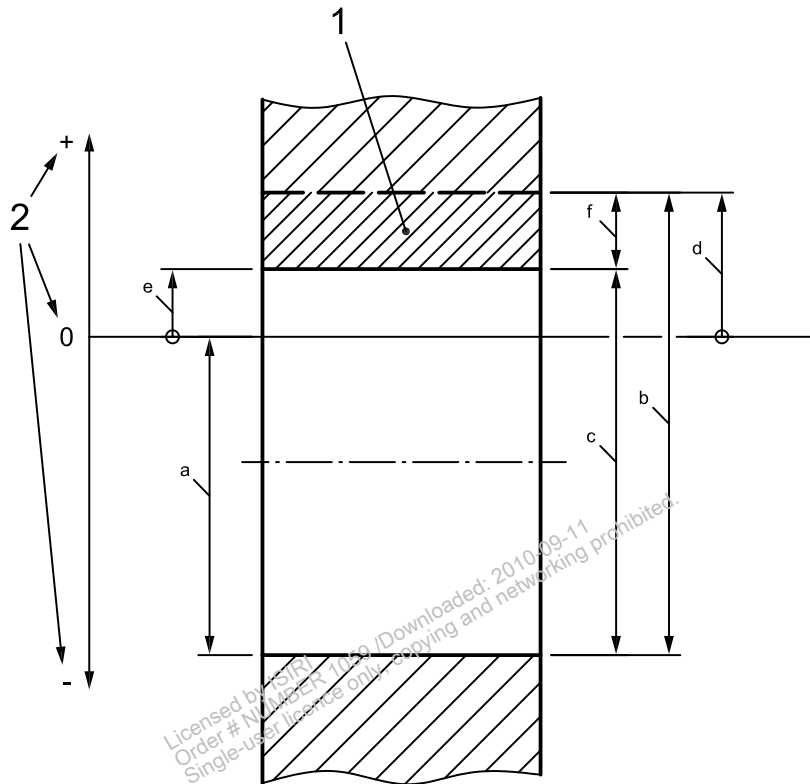

Key

- 1 tolerance interval
- 2 sign convention for deviations
- a Nominal size.
- b Upper limit of size.
- c Lower limit of size.
- d Upper limit deviation.
- e Lower limit deviation (in this case also fundamental deviation).
- f Tolerance.

NOTE The horizontal continuous line, which limits the tolerance interval, represents the fundamental deviations for a hole. The dashed line, which limits the tolerance interval, represents the other limit deviation for a hole.

Figure 1 — Illustration of definitions (a hole is used in the example)

3.2.5.2

lower limit deviation

EI (to be used for internal features of size)

ei (to be used for external features of size)

lower limit of size minus nominal size

See Figure 1.

NOTE Lower limit deviation is a signed value and may be negative, zero or positive.

3.2.6

fundamental deviation

limit deviation that defines the placement of the tolerance interval in relation to the nominal size

NOTE 1 The fundamental deviation is that limit deviation, which defines that limit of size which is the nearest to the nominal size (see Figure 1 and 4.1.2.5).

NOTE 2 The fundamental deviation is identified by a letter (e.g. B, d).

3.2.7 **Δ value**

variable value added to a fixed value to obtain the fundamental deviation of an internal feature of size

See Table 3.

3.2.8**tolerance**

difference between the upper limit of size and the lower limit of size

NOTE 1 The tolerance is an absolute quantity without sign.

NOTE 2 The tolerance is also the difference between the upper limit deviation and the lower limit deviation.

3.2.8.1**tolerance limits**

specified values of the characteristic giving upper and/or lower bounds of the permissible value

3.2.8.2**standard tolerance****IT**

any tolerance belonging to the ISO code system for tolerances on linear sizes

NOTE The letters in the abbreviated term "IT" stand for "International Tolerance".

3.2.8.3**standard tolerance grade**

group of tolerances for linear sizes characterized by a common identifier

NOTE 1 In the ISO code system for tolerances on linear sizes, the standard tolerance grade identifier consists of IT followed by a number (e.g. IT7); see 4.1.2.3.

NOTE 2 A specific tolerance grade is considered as corresponding to the same level of accuracy for all nominal sizes.

3.2.8.4**tolerance interval**

variable values of the size between and including the tolerance limits

NOTE 1 The former term "tolerance zone", which was used in connection with linear dimensioning (according to ISO 286-1:1988), has been changed to "tolerance interval" since an interval refers to a range on a scale whereas a tolerance zone in GPS refers to a space or an area, e.g. tolerancing according to ISO 1101.

NOTE 2 For the purpose of ISO 286, the interval is contained between the upper and the lower limits of size. It is defined by the magnitude of the tolerance and its placement relative to the nominal size (see Figure 1).

NOTE 3 The tolerance interval does not necessarily include the nominal size (see Figure 1). Tolerance limits may be two-sided (values on both sides of the nominal size) or one-sided (both values on one side of the nominal size). The case where the one tolerance limit is on one side, the other limit value being zero, is a special case of a one-sided indication.

3.2.8.5**tolerance class**

combination of a fundamental deviation and a standard tolerance grade

NOTE In the ISO code system for tolerances on linear sizes, the tolerance class consists of the fundamental deviation identifier followed by the tolerance grade number (e.g. D13, h9, etc.), see 4.2.1.

3.3 Terminology related to fits

The concepts in this clause relate only to nominal features of size (perfect form). For the model definition of a nominal feature of size, see ISO 17450-1:—, 3.18.

For the determination of a fit, see 5.3.

3.3.1

clearance

difference between the size of the hole and the size of the shaft when the diameter of the shaft is smaller than the diameter of the hole

NOTE In the calculation of clearance, the obtained values are positive (see B.2).

3.3.1.1

minimum clearance

(in a clearance fit) difference between the lower limit of size of the hole and the upper limit of size of the shaft

See Figure 2.

3.3.1.2

maximum clearance

(in a clearance or transition fit) difference between the upper limit of size of the hole and the lower limit of size of the shaft

See Figures 2 and 4.

3.3.2

interference

difference before mating between the size of the hole and the size of the shaft when the diameter of the shaft is larger than the diameter of the hole

NOTE In the calculation of an interference, the obtained values are negative (see B.2).

3.3.2.1

minimum interference

(in an interference fit) difference between the upper limit of size of the hole and the lower limit of size of the shaft

See Figure 3.

3.3.2.2

maximum interference

(in an interference or transition fit) difference between the lower limit of size of the hole and the upper limit of size of the shaft

See Figures 3 and 4.

3.3.3

fit

relationship between an external feature of size and an internal feature of size (the hole and shaft of the same type) which are to be assembled

3.3.3.1

clearance fit

fit that always provides a clearance between the hole and shaft when assembled, i.e. the lower limit of size of the hole is either larger than or, in the extreme case, equal to the upper limit of size of the shaft

See Figure 2.

3.3.3.2

interference fit

fit that always provides an interference between the hole and the shaft when assembled, i.e. the upper limit of size of the hole is either smaller than or, in the extreme case, equal to the lower limit of size of the shaft

See Figure 3.

3.3.3.3**transition fit**

fit which may provide either a clearance or an interference between the hole and the shaft when assembled

See Figure 4.

NOTE In a transition fit, the tolerance intervals of the hole and the shaft overlap either completely or partially; therefore, if there is a clearance or an interference depends on the actual sizes of the hole and the shaft.

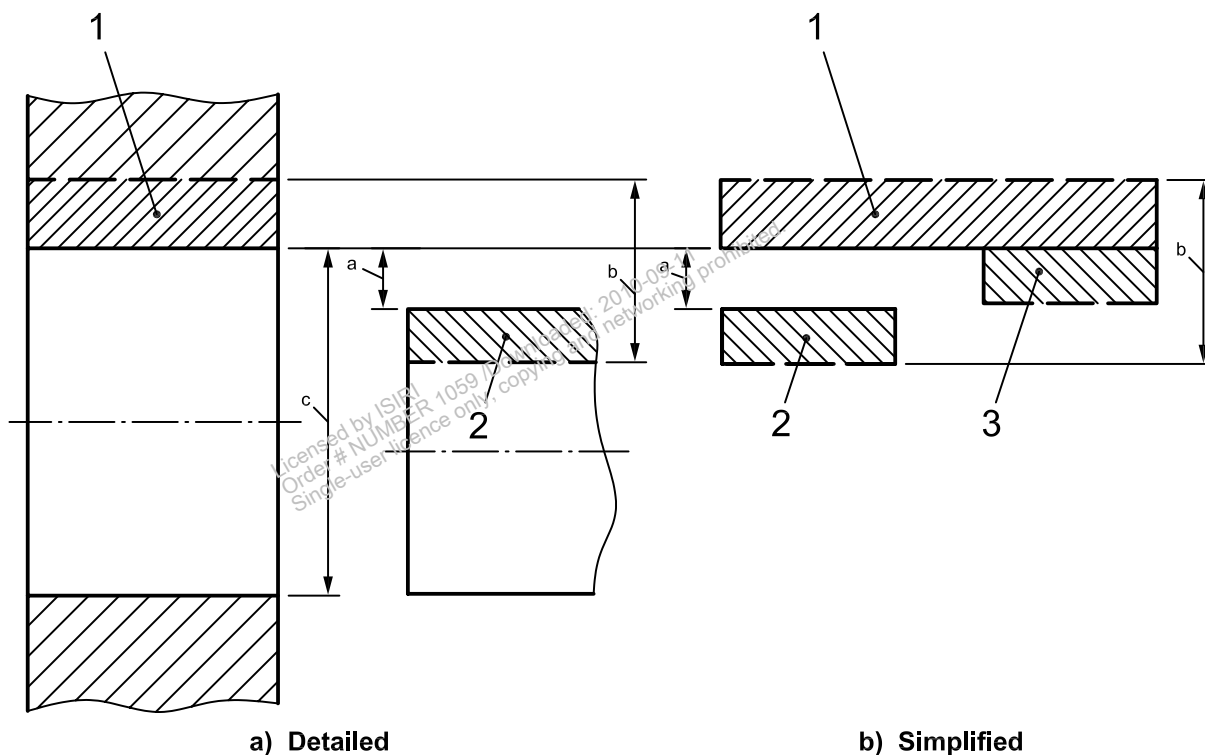
**Key**

- 1 tolerance interval of the hole
- 2 tolerance interval of the shaft, case 1: when the upper limit of size of the shaft is lower than the lower limit of size of the hole, the minimum clearance is larger than zero
- 3 tolerance interval of the shaft, case 2: when the upper limit of size of the shaft is identical to the lower limit of size of the hole, the minimum clearance is zero
- a Minimum clearance.
- b Maximum clearance.
- c Nominal size = lower limit of size of the hole.

NOTE The horizontal continuous wide lines, which limit the tolerance intervals, represent the fundamental deviations. The dashed lines, which limit the tolerance intervals, represent the other limit deviations.

Figure 2 — Illustration of definitions of a clearance fit (nominal model)

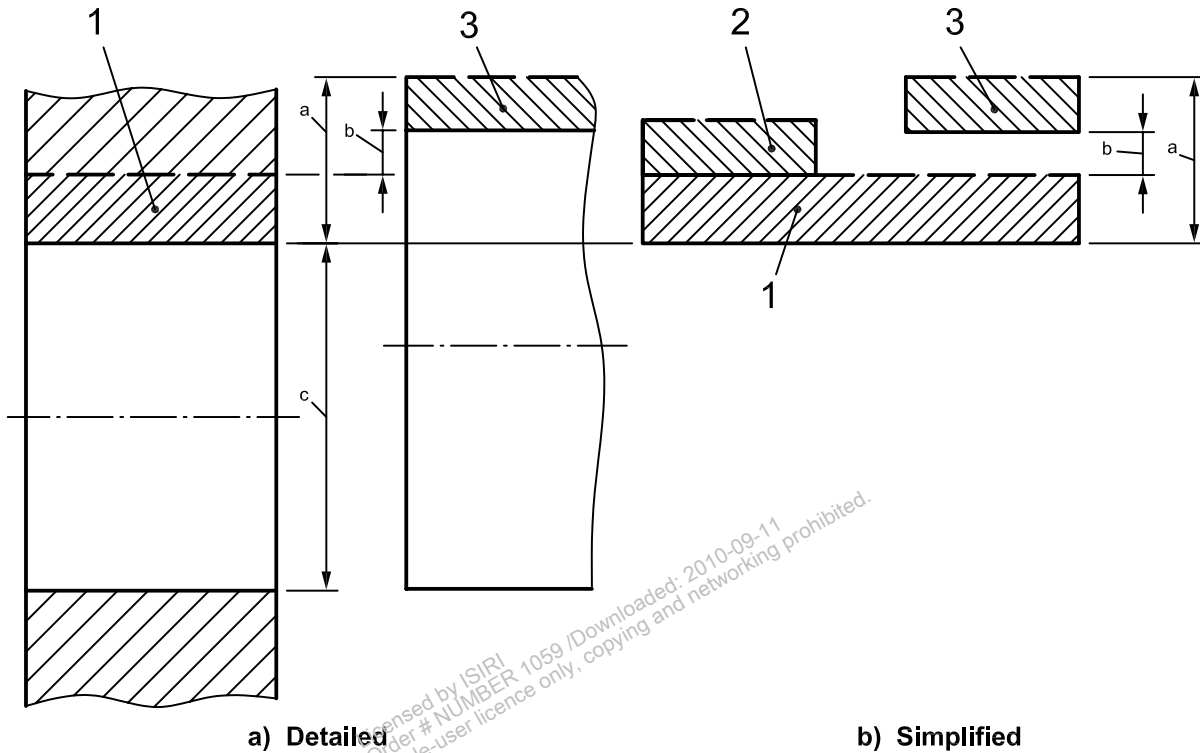

a) Detailed

b) Simplified

Key

- 1 tolerance interval of the hole
- 2 tolerance interval of the shaft, case 1: when the lower limit of size of the shaft is identical to the upper limit of size of the hole, the minimum interference is zero
- 3 tolerance interval of the shaft, case 2: when the lower limit of size of the shaft is larger than the upper limit of size of the hole, the minimum interference is larger than zero
- a Maximum interference.
- b Minimum interference.
- c Nominal size = lower limit of size of the hole.

NOTE The horizontal continuous wide lines, which limit the tolerance intervals, represent the fundamental deviations. The dashed lines, which limit the tolerance intervals, represent the other limit deviations.

Figure 3 — Illustration of definitions of an interference fit (nominal model)

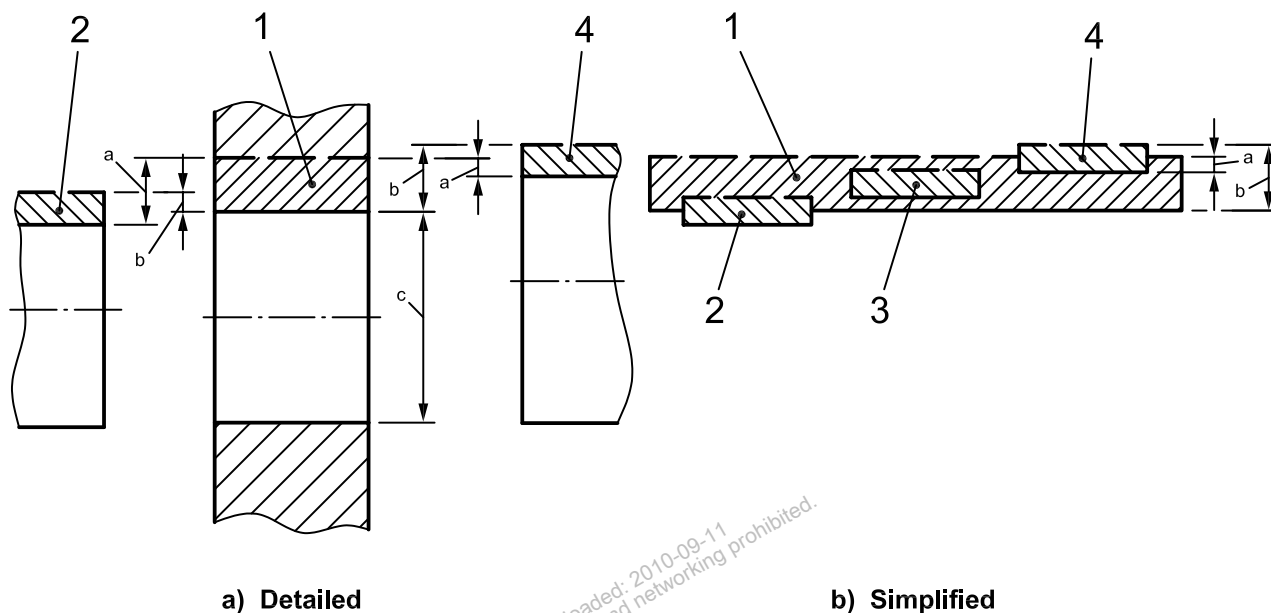

Key

- 1 tolerance interval of the hole
- 2-4 tolerance interval of the shaft (some possible placements are shown)
- a Maximum clearance.
- b Maximum interference.
- c Nominal size = lower limit of size of the hole.

NOTE The horizontal continuous wide lines, which limit the tolerance intervals, represent the fundamental deviations. The dashed lines, which limit the tolerance intervals, represent the other limit deviations.

Figure 4 — Illustration of definitions of a transition fit (nominal model)

3.3.4

span of a fit

arithmetic sum of the size tolerances on two features of size comprising the fit

See Figure B.1.

NOTE 1 The span of a fit is an absolute value without sign and expresses the possible nominal variation of the fit.

NOTE 2 The span of a clearance fit is the difference between the maximum and minimum clearances. The span of an interference fit is the difference between the maximum and minimum interferences. The span of a transition fit is the sum of the maximum clearance and maximum interference (see Annex B).

3.4 Terminology related to the ISO fit system

3.4.1

ISO fit system

system of fits comprising shafts and holes toleranced by the ISO code system for tolerances on linear sizes

NOTE The pre-condition for the application of the ISO code system for tolerances on linear sizes for the features forming a fit is that the nominal sizes of the hole and the shaft are identical.

3.4.1.1

hole-basis fit system

fits where the fundamental deviation of the hole is zero, i.e. the lower limit deviation is zero

See Figure 5.

NOTE A fit system in which the lower limit of size of the hole is identical to the nominal size. The required clearances or interferences are obtained by combining shafts of various tolerance classes with basic holes of a tolerance class with a fundamental deviation of zero.

3.4.1.2 shaft-basis fit system

fits where the fundamental deviation of the shaft is zero, i.e. the upper limit deviation is zero

See Figure 6.

NOTE A fit system in which the upper limit of size of the shaft is identical to the nominal size. The required clearances or interferences are obtained by combining holes of various tolerance classes with basic shafts of a tolerance class with a fundamental deviation of zero.

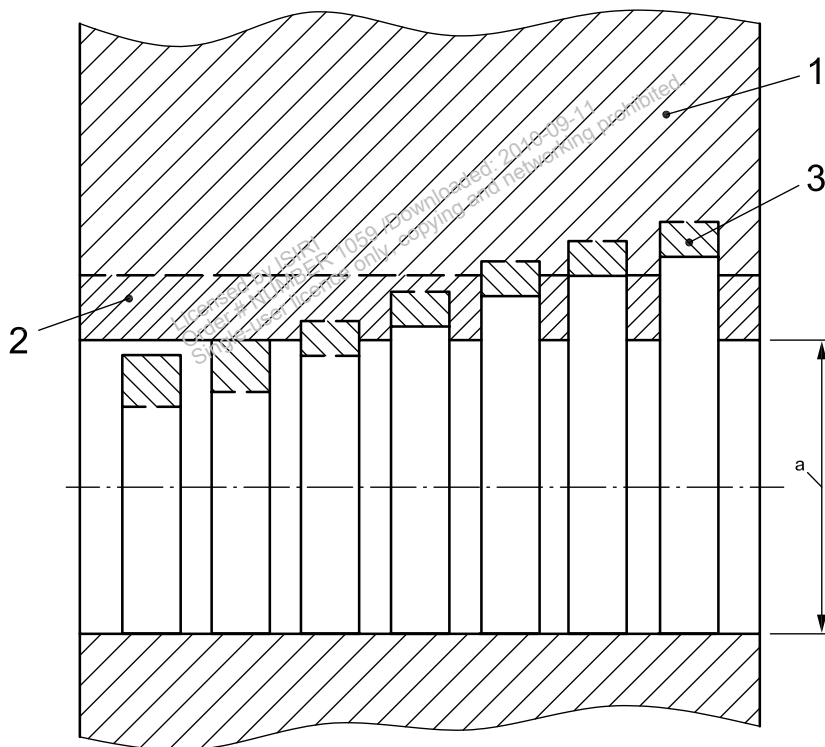

Key

- 1 basic hole "H"
- 2 tolerance interval of the basic hole
- 3 tolerance interval of the different shafts
- ^a Nominal size.

NOTE 1 The horizontal continuous lines, which limit the tolerance intervals, represent the fundamental deviations for a basic hole and different shafts.

NOTE 2 The dashed lines, which limit the tolerance intervals, represent the other limit deviations.

NOTE 3 The figure shows the possibility of combinations between a basic hole and different shafts, related to their standard tolerance grades.

NOTE 4 Possible examples of hole-basis fits are: H7/h6, H6/k5, H6/p4.

Figure 5 — Hole-basis fit system

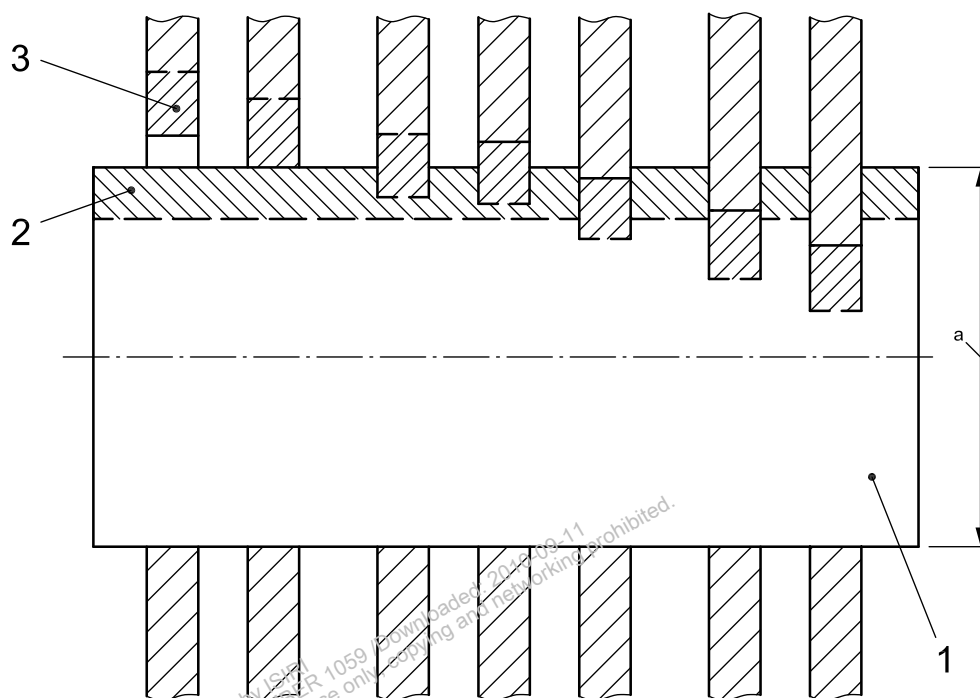
**Key**

- 1 basic shaft "h"
 2 tolerance interval of the basic shaft
 3 tolerance interval of the different holes
 a Nominal size.

NOTE 1 The horizontal continuous lines, which limit the tolerance intervals, represent the fundamental deviations for a basic shaft and different holes.

NOTE 2 The dashed lines, which limit the tolerance intervals, represent the other limit deviations.

NOTE 3 The figure shows the possibility of combinations between a basic shaft and different holes, related to their standard tolerance grades.

NOTE 4 Possible examples of shaft-basis fits are: h6/G7, h6/H6, h6/M6.

Figure 6 — Shaft-basis fit system

4 ISO code system for tolerances on linear sizes

4.1 Basic concepts and designations

4.1.1 Relation to ISO 14405-1

A feature of size may be toleranced by using the ISO code system defined in this part of ISO 286 or by using + and – tolerancing according to ISO 14405-1. Both indications are equivalent.

EXAMPLE 1 $32^x y$ is equivalent to 32 "code"

where

- 32 is the nominal size, in millimeters;
 x is the upper tolerance limit (x can be positive, zero or negative);
 y is the lower tolerance limit (y can be positive, zero or negative);
 "code" is the tolerance class according to 4.2.1.

If a fit shall be toleranced, the envelope requirement according to ISO 14405-1 may be indicated (see A.2).

EXAMPLE 2 32 y^{x} Ⓔ is equivalent to 32 “code” Ⓔ

4.1.2 Tolerance class

4.1.2.1 General

The tolerance class contains information on the magnitude of the tolerance and the position of the tolerance interval relative to the nominal size of the feature of size.

4.1.2.2 Magnitude of the tolerance

The tolerance class expresses the magnitude of the tolerance. The magnitude of the tolerance is a function of the standard tolerance grade number and the nominal size of the toleranced feature.

4.1.2.3 Standard tolerance grades

The standard tolerance grades are designated by the letters IT followed by the grade number, e.g. IT7.

Values of standardised tolerances are given in Table 1. Each of the columns gives the values of the tolerances for one standard tolerance grade between standard tolerance grades IT01 and IT18 inclusive. Each row in Table 1 is representing one range of sizes. The limits of the ranges of sizes are given in the first column of Table 1.

NOTE 1 When the standard tolerance grade is associated with a letter or letters representing a fundamental deviation to form a tolerance class, the letters IT are omitted, e.g. H7.

NOTE 2 From IT6 to IT18, the standard tolerances are multiplied by the factor 10 at each fifth step. This rule applies to all standard tolerances and may be used to extrapolate values for IT grades not given in Table 1.

EXAMPLE For the nominal size range 120 mm up to and including 180 mm, the value of IT20 is:

$$IT20 = IT15 \times 10 = 1,6 \text{ mm} \times 10 = 16 \text{ mm}$$

4.1.2.4 Placement of tolerance interval

The tolerance interval (former term: tolerance zone) is a variable value contained between the upper and the lower limits of size. The tolerance class expresses the position of the tolerance interval relative to the nominal size, by means of the fundamental deviation. The information on the position of the tolerance interval, i.e. on the fundamental deviation, is identified by one or more letters, called the fundamental deviation identifiers:

A graphical overview of the position of the tolerance intervals relative to the nominal sizes and the signs (+ or -) of the fundamental deviations for holes and shafts are given in Figures 7, 8 and 9.

4.1.2.5 Fundamental deviation

The fundamental deviation is that limit deviation, which defines that limit of size, which is the nearest to the nominal size (see Figure 7).

The fundamental deviations are identified and controlled by:

- upper case letter(s) for holes (A . . . ZC), see Tables 2 and 3;
- lower case letter(s) for shafts (a . . . zc), see Tables 4 and 5.

NOTE 1 To avoid confusion, the following letters are not used: I, i; L, l; O, o; Q, q; W, w.

NOTE 2 The fundamental deviations are not defined individually for each specific nominal size, but for ranges of nominal sizes as given in Tables 2 to 5.

The fundamental deviation in micrometres is a function of the identifier (letter) and the nominal size of the tolerated feature.

Tables 2 and 3 contain the signed values of the fundamental deviations for hole tolerances. Tables 4 and 5 contain the signed values of the fundamental deviations for shaft tolerances.

The sign + is used when the tolerance limit identified by the fundamental deviation is above nominal size and the sign – is used when the tolerance limit identified by the fundamental deviation is below nominal size.

Each of the columns in Tables 2 to 5 gives the values of the fundamental deviation for one fundamental deviation identifier letter. Each of the rows is representing one range of sizes. The limits of the ranges of sizes are given in the first column of the tables.

The other limit deviation (upper or lower) is established from the fundamental deviation and the standard tolerance (IT) as shown in Figures 8 and 9.

NOTE 3 The concept of fundamental deviations does not apply to JS and js. Their tolerance limits are distributed symmetrically about the nominal size line (see Figures 8 and 9).

NOTE 4 The ranges of sizes in Tables 2 to 5 are in many cases (for deviations a to c and r to zc or A to C and R to ZC) subdivisions of the main ranges of Table 1.

The last six columns on the right side of Table 3 contain a separate table with Δ -values. Δ is a function of the tolerance grade and the nominal size of the tolerated feature. It is only relevant for deviations K to ZC and for standard tolerance grades IT3 to IT7/IT8.

The value of Δ shall be added to the fixed value given in the main table, whenever + Δ is indicated, to form the correct value of the fundamental deviation.

4.2 Designation of the tolerance class (writing rules)

4.2.1 General

The tolerance class shall be designated by the combination of an upper-case letter(s) for holes and lower-case letters for shafts identifying the fundamental deviation and by the number representing the standard tolerance grade.

EXAMPLE H7 (holes), h7 (shafts).

4.2.2 Size and its tolerance

A size and its tolerance shall be designated by the nominal size followed by the designation of the required tolerance class, or shall be designated by the nominal size followed by + and/or – limit deviations (see ISO 14405-1).

ISO 286-1:2010(E)

In the following examples the indicated limit deviations are equivalent to the indicated tolerance classes.

EXAMPLE 1

ISO 286		ISO 14405-1
32 H7	≡	$32 \begin{matrix} +0,025 \\ 0 \end{matrix}$
80 js15	≡	$80 \pm 0,6$
100 g6 (E)	≡	$100 \begin{matrix} -0,012 \\ -0,034 \end{matrix}$ (E)

NOTE When using + or – tolerancing determined from a tolerance class, the tolerance class may be added in brackets for auxiliary information purposes and vice versa.

EXAMPLE 2 $32 H7 \begin{pmatrix} +0,025 \\ 0 \end{pmatrix} \equiv 32 \begin{matrix} +0,025 \\ 0 \end{matrix} (H7)$

4.2.3 Determination of a tolerance class

Determination of a tolerance class is derived from fit requirements (clearances, interferences), see 5.3.4.

4.3 Determination of the limit deviations (reading rules)

4.3.1 General

The determination of the limit deviations for a given toleranced size, e.g. the transformation of a tolerance class into + and – tolerancing can be performed by the use of:

- the Tables 1 to 5 of this part of ISO 286 (see 4.3.2); or
- the tables of ISO 286-2 (see 4.3.3). Only selected cases are covered.

4.3.2 Determination of limit deviations using the tables of this part of ISO 286

4.3.2.1 General

The tolerance class is decomposed into the fundamental deviation identifier and the standard tolerance grade number.

EXAMPLE Toleranced size for a hole 90 F7 (E) and for a shaft 90 f7 (E)

where

- 90 is the nominal size in millimetres;
- F is the fundamental deviation identifier for a hole;
- f is the fundamental deviation identifier for a shaft;
- 7 is the standard tolerance grade number;
- (E) is the envelope requirement according to ISO 14405-1 (if necessary).

4.3.2.2 Standard tolerance grade

From the standard tolerance grade number, the standard tolerance grade (IT_x) is obtained.

From the nominal size and the standard tolerance grade the magnitude of the tolerance, e.g. the standard tolerance value is obtained by the use of Table 1.

EXAMPLE 1 Toleranced size for a hole 90 F7 $\text{\textcircled{E}}$ and for a shaft 90 f7 $\text{\textcircled{E}}$

The standard tolerance grade number is "7", hence, the standard tolerance grade is IT7.

The standard tolerance value has to be taken from Table 1 in the line of the nominal size range above 80 mm up to and including 120 mm and in the column of the standard tolerance grade IT7.

Consequently, the standard tolerance value is: 35 μm .

EXAMPLE 2 Toleranced size for a hole 28 P9 $\text{\textcircled{E}}$

The standard tolerance grade number is "9", hence, the standard tolerance grade is IT9.

The standard tolerance value has to be taken from Table 1 in the line of the nominal size range above 18 mm up to and including 30 mm and in the column of the standard tolerance grade IT9.

Consequently the standard tolerance value is: 52 μm .

4.3.2.3 Position of the tolerance interval

From the nominal size and the fundamental deviation identifier the fundamental deviation (the upper or lower limit deviation) is obtained by use of Tables 2 and 3 for holes (upper-case letters) and Tables 4 and 5 for shafts (lower-case letters).

EXAMPLE 1 Toleranced size for a hole 90 F7 $\text{\textcircled{E}}$

The fundamental deviation identifier is "F", hence, this is a hole case and Table 2 applies.

From Table 2, line "80 to 100" and column "F", the lower limit deviation EI is: +36 μm .

EXAMPLE 2 Toleranced size for a shaft 90 f7 $\text{\textcircled{E}}$

The fundamental deviation identifier is "f", hence, this is a shaft case and Table 4 applies.

From Table 4, line "80 to 100" and column "f", the upper limit deviation es is: -36 μm .

EXAMPLE 3 Toleranced size for a hole 28 P9 $\text{\textcircled{E}}$

The fundamental deviation identifier is "P", hence, this is a hole case and Table 3 applies.

From Table 3, line "24 to 30" and column "P", the upper limit deviation ES is: -22 μm .

4.3.2.4 Establishment of limit deviations

One of the limit deviations (upper or lower) has already been determined in 4.3.2.3. The other limit deviations (upper or lower) are obtained by calculation according to the formulae given in Figures 8 and 9 and using the standard tolerance values of Table 1.

EXAMPLE 1 Toleranced size for a hole 90 F7 $\text{\textcircled{E}}$

According to 4.3.2.2 $IT7 = 35 \mu\text{m}$

According to 4.3.2.3 Lower limit deviation $EI = +36 \mu\text{m}$

According to formula in Figure 8 Upper limit deviation $ES = EI + IT = +36 + 35 = +71 \mu\text{m}$

From that follows: 90 F7 $\text{\textcircled{E}} \equiv 90^{+0,071}_{+0,036} \text{\textcircled{E}}$

EXAMPLE 2 Toleranced size for a shaft 90 f7 $\text{\textcircled{E}}$

According to 4.3.2.2 $IT7 = 35 \mu\text{m}$

According to 4.3.2.3 Upper limit deviation $es = -36 \mu\text{m}$

According to formula in Figure 9 Lower limit deviation $ei = es - IT = -36 - 35 = -71 \mu\text{m}$

From that follows: 90 f7 $\text{\textcircled{E}} \equiv 90^{-0,036}_{-0,071} \text{\textcircled{E}}$

EXAMPLE 3 Toleranced size for a hole 29 P9 $\text{\textcircled{E}}$

According to 4.3.2.2 $IT7 = 52 \mu\text{m}$

According to 4.3.2.3 Upper limit deviation $ES = -22 \mu\text{m}$

According to formula in Figure 8 Lower limit deviation $EI = ES - IT = -22 - 52 = -74 \mu\text{m}$

From that follows: $29 \text{ P9 } \text{\textcircled{E}} \equiv 29 \begin{matrix} -0,022 \\ -0,074 \end{matrix} \text{\textcircled{E}}$

4.3.2.5 Establishment of limit deviations using Δ -values

For determining the fundamental deviations K, M and N for standard tolerance grades up to and including IT8 and P to ZC up to and including IT7, the values Δ from the columns on the right of Table 3 shall be taken into consideration.

EXAMPLE 1 Toleranced size for a hole 20 K7 $\text{\textcircled{E}}$

Table 1: IT7 in the range above 18 mm up to and including 30 mm $IT7 = 21 \mu\text{m}$

Table 3: Δ in the range above 18 mm up to and including 24 mm for IT7 $\Delta = 8 \mu\text{m}$

For K in the range above 18 mm up to and including 24 mm:

Upper limit deviation $ES = -2 + \Delta = -2 + 8 = +6 \mu\text{m}$

Lower limit deviation $EI = ES - IT = +6 - 21 = -15 \mu\text{m}$

From that follows: $20 \text{ K7 } \text{\textcircled{E}} \equiv 20 \begin{matrix} +0,006 \\ -0,015 \end{matrix} \text{\textcircled{E}}$

EXAMPLE 2 Toleranced size for a hole 40 U6

Table 1: IT6 in the range above 30 mm up to and including 50 mm $IT6 = 16 \mu\text{m}$

Table 3: Δ in the range above 30 mm up to and including 40 mm for IT6 $\Delta = 5 \mu\text{m}$

For U in the range above 30 mm up to and including 40 mm:

Upper limit deviation $ES = -60 + \Delta = -60 + 5 = -55 \mu\text{m}$

Lower limit deviation $EI = ES - IT = -55 - 16 = -71 \mu\text{m}$

From that follows: $40 \text{ U6 } \equiv 40 \begin{matrix} -0,055 \\ -0,071 \end{matrix}$

NOTE For this interference fit, the envelope requirement has been omitted intentionally. For strong interference fits, it is not necessary to apply the envelope requirement.

4.3.3 Determination of limit deviations using the tables of ISO 286-2

The limit deviations for a given toleranced size may be selected from the Tables of ISO 286-2.

EXAMPLE Given toleranced size: 60 M6 $\text{\textcircled{E}}$

In Table 9 of ISO 286-2:—, the limit deviations have to be taken in the line of the nominal size range above 50 mm up to and including 80 mm and in the column of the standard tolerance grade number 6.

Consequently, the limit deviations are:

Upper limit deviation $ES = -5 \mu\text{m}$

Lower limit deviation $EI = -24 \mu\text{m}$

From that follows: $60 \text{ M6 } \text{\textcircled{E}} \equiv 60 \begin{matrix} -0,005 \\ -0,024 \end{matrix} \text{\textcircled{E}}$

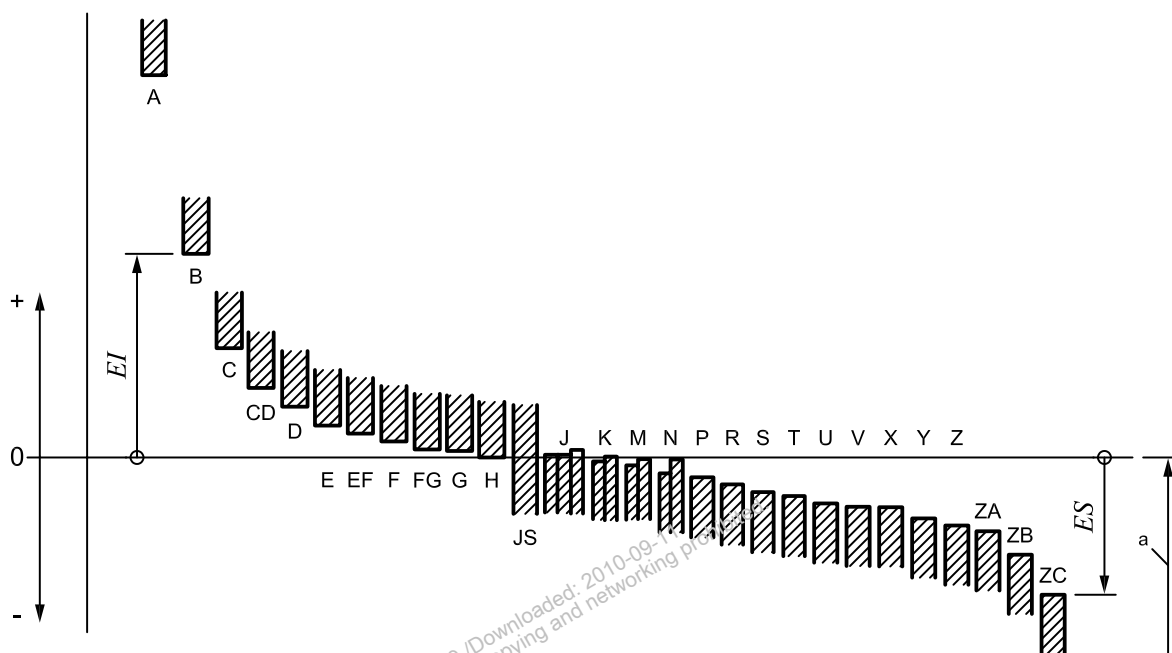

a) Holes (internal features of size)

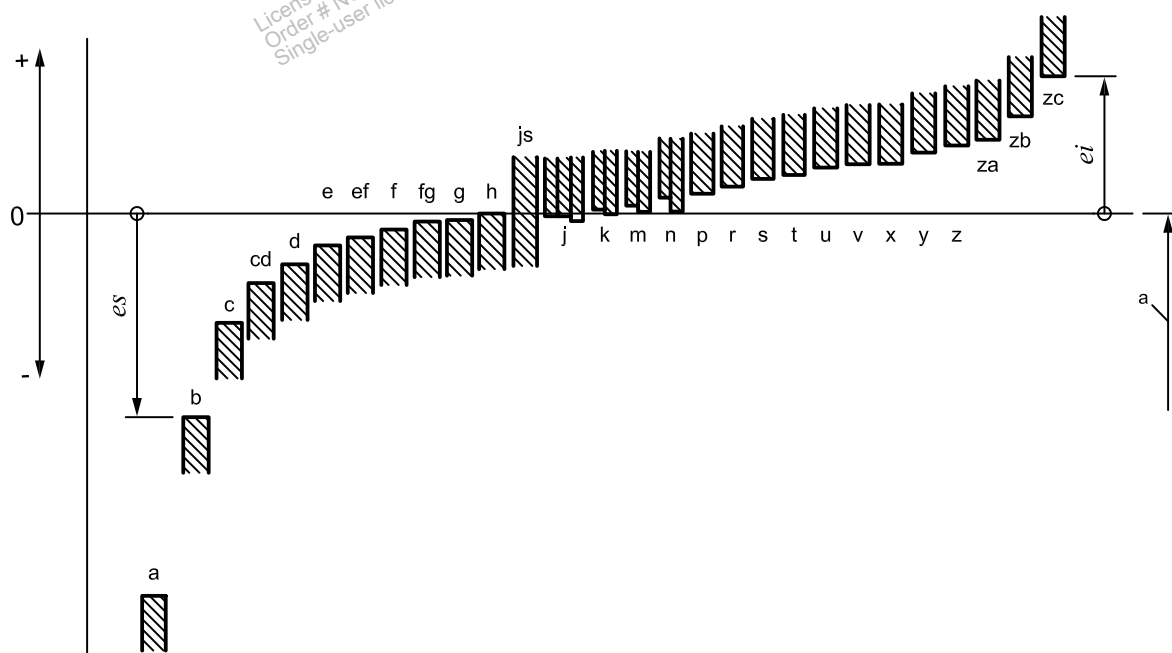

b) Shafts (external features of size)

Key

EI, ES fundamental deviations of holes (examples)
ei, es fundamental deviations of shafts (examples)

^a Nominal size.

NOTE 1 According to convention, the fundamental deviation is the one defining the nearest limit to the nominal size.

NOTE 2 For details concerning fundamental deviations for J/j, K/k, M/m and N/n, see Figures 8 and 9.

Figure 7 — Schematic representation of the placement of the tolerance interval (fundamental deviation) relative to the nominal size

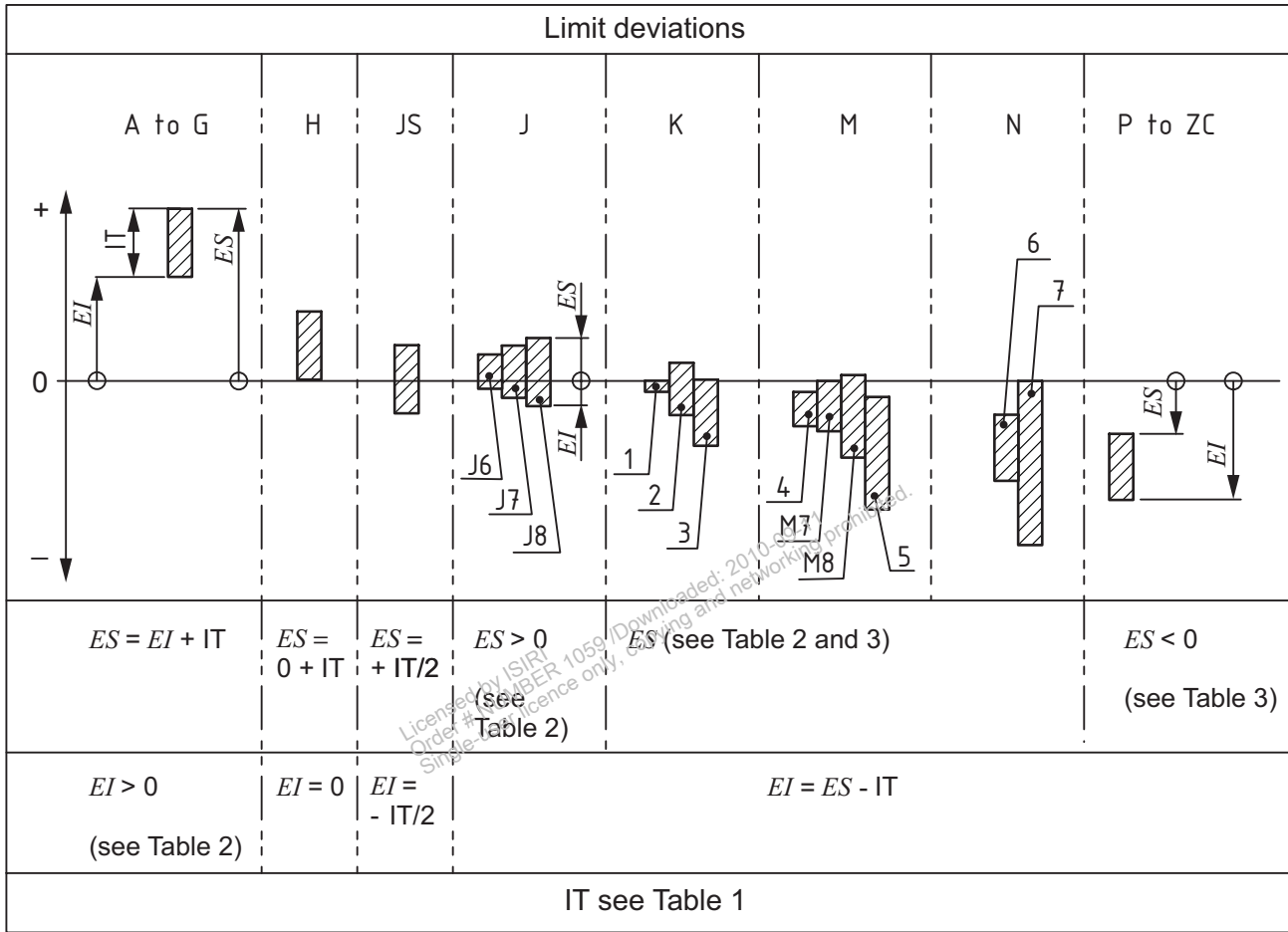

Key

- 1 K1 to K3, and also K4 to K8 for sizes for which $— < \text{nominal size} \leq 3 \text{ mm}$ (for the significance of the dash, see e.g. footnote “a” to Table 2)
- 2 K4 to K8 for sizes: $3 \text{ mm} < \text{nominal size} \leq 500 \text{ mm}$
- 3 K9 to K18
- 4 M1 to M6
- 5 M9 to M18
- 6 N1 to N8
- 7 N9 to N18

NOTE The represented tolerance intervals correspond approximately to a nominal size range of above 10 mm up to and including 18 mm.

Figure 8 — Limit deviations for holes

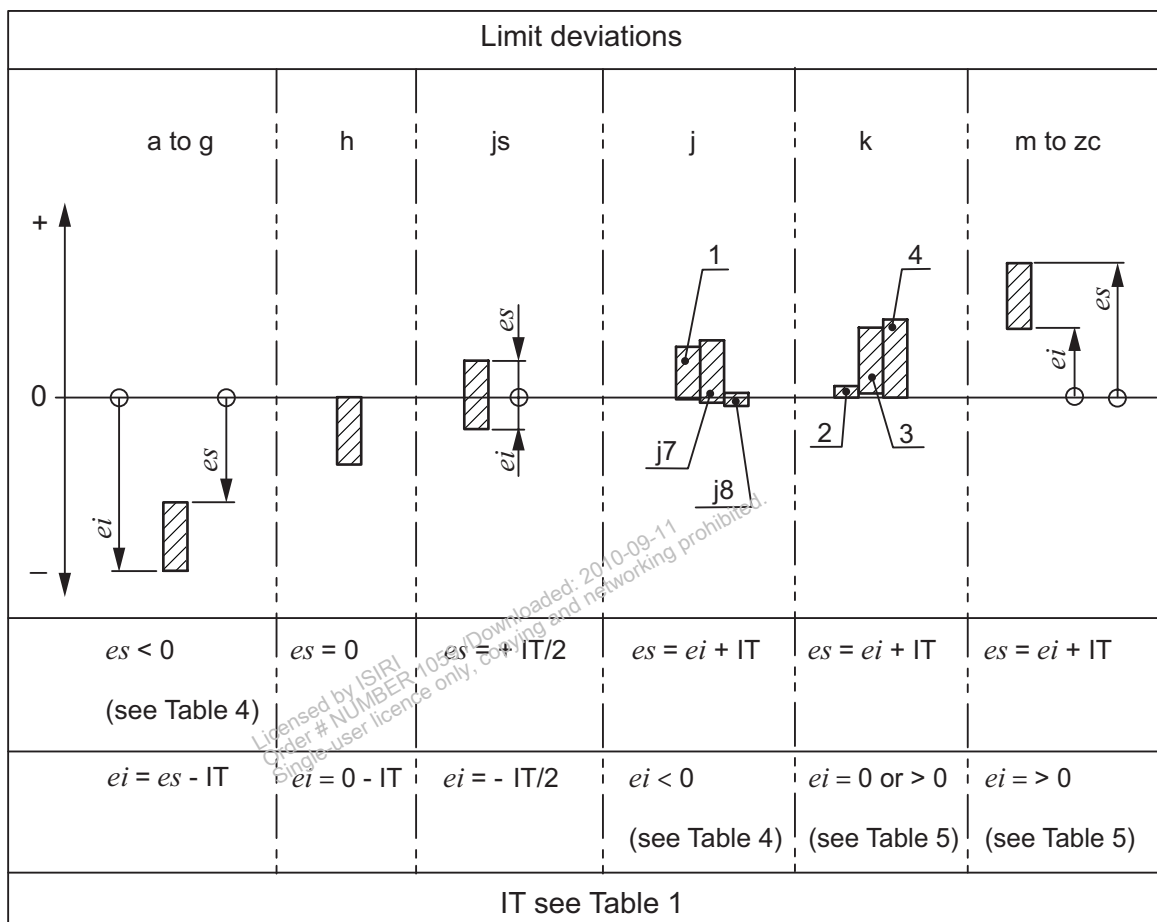

Key

- 1 j5, j6
- 2 k1 to k3, and also k4 to k7 for sizes for which $— < \text{nominal size} \leq 3 \text{ mm}$ (for the significance of the dash, see e.g. footnote “a” to Table 2)
- 3 k4 to k7 for sizes for which $3 \text{ mm} < \text{nominal size} \leq 500 \text{ mm}$
- 4 k8 to k18

NOTE The represented tolerance intervals correspond approximately to a nominal size range of above 10 mm up to and including 18 mm.

Figure 9 — Limit deviations for shafts

Table 1 — Values of standard tolerance grades for nominal sizes up to 3 150 mm

Nominal size mm		Standard tolerance grades																			
		IT01	IT0	IT1	IT2	IT3	IT4	IT5	IT6	IT7	IT8	IT9	IT10	IT11	IT12	IT13	IT14	IT15	IT16	IT17	IT18
Above	Up to and including	Standard tolerance values																			
		µm											mm								
—	3	0,3	0,5	0,8	1,2	2	3	4	6	10	14	25	40	60	0,1	0,14	0,25	0,4	0,6	1	1,4
3	6	0,4	0,6	1	1,5	2,5	4	5	8	12	18	30	48	75	0,12	0,18	0,3	0,48	0,75	1,2	1,8
6	10	0,4	0,6	1	1,5	2,5	4	6	9	15	22	36	58	90	0,15	0,22	0,36	0,58	0,9	1,5	2,2
10	18	0,5	0,8	1,2	2	3	5	8	11	18	27	43	70	110	0,18	0,27	0,43	0,7	1,1	1,8	2,7
18	30	0,6	1	1,5	2,5	4	6	9	13	21	33	52	84	130	0,21	0,33	0,52	0,84	1,3	2,1	3,3
30	50	0,6	1	1,5	2,5	4	7	11	16	25	39	62	100	160	0,25	0,39	0,62	1	1,6	2,5	3,9
50	80	0,8	1,2	2	3	5	8	13	19	30	46	74	120	190	0,3	0,46	0,74	1,2	1,9	3	4,6
80	120	1	1,5	2,5	4	6	10	15	22	35	54	87	140	220	0,35	0,54	0,87	1,4	2,2	3,5	5,4
120	180	1,2	2	3,5	5	8	12	18	25	40	63	100	160	250	0,4	0,63	1	1,6	2,5	4	6,3
180	250	2	3	4,5	7	10	14	20	29	46	72	115	185	290	0,46	0,72	1,15	1,85	2,9	4,6	7,2
250	315	2,5	4	6	8	12	16	23	32	52	81	130	210	320	0,52	0,81	1,3	2,1	3,2	5,2	8,1
315	400	3	5	7	9	13	18	25	36	57	89	140	230	360	0,57	0,89	1,4	2,3	3,6	5,7	8,9
400	500	4	6	8	10	15	20	27	40	63	97	155	250	400	0,63	0,97	1,55	2,5	4	6,3	9,7
500	630			9	11	16	22	32	44	70	110	175	280	440	0,7	1,1	1,75	2,8	4,4	7	11
630	800			10	13	18	25	36	50	80	125	200	320	500	0,8	1,25	2	3,2	5	8	12,5
800	1 000			11	15	21	28	40	56	90	140	230	360	560	0,9	1,4	2,3	3,6	5,6	9	14
1 000	1 250			13	18	24	33	47	66	105	165	260	420	660	1,05	1,65	2,6	4,2	6,6	10,5	16,5
1 250	1 600			15	21	29	39	55	78	125	195	310	500	780	1,25	1,95	3,1	5	7,8	12,5	19,5
1 600	2 000			18	25	35	46	65	92	150	230	370	600	920	1,5	2,3	3,7	6	9,2	15	23
2 000	2 500			22	30	41	55	78	110	175	280	440	700	1 100	1,75	2,8	4,4	7	11	17,5	28
2 500	3 150			26	36	50	68	96	135	210	330	540	860	1 350	2,1	3,3	5,4	8,6	13,5	21	33

Table 2 — Values of the fundamental deviations for holes A to M

Fundamental deviation values in micrometres

Nominal size mm		Fundamental deviation values																		
		Lower limit deviation, <i>EI</i>											Upper limit deviation, <i>ES</i>							
Above	Up to and including	All standard tolerance grades											IT6	IT7	IT8	Up to and including IT8	Above IT8	Up to and including IT8	Above IT8	
		A ^a	B ^a	C	CD	D	E	EF	F	FG	G	H								JS
—	3	+270	+140	+60	+34	+20	+14	+10	+6	+4	+2	0		+2	+4	+6	0	0	-2	-2
3	6	+270	+140	+70	+46	+30	+20	+14	+10	+6	+4	0		+5	+6	+10	-1 + Δ		-4 + Δ	-4
6	10	+280	+150	+80	+56	+40	+25	+18	+13	+8	+5	0		+5	+8	+12	-1 + Δ		-6 + Δ	-6
10	14	+290	+150	+95	+70	+50	+32	+23	+16	+10	+6	0		+6	+10	+15	-1 + Δ		-7 + Δ	-7
14	18																			
18	24	+300	+160	+110	+85	+65	+40	+28	+20	+12	+7	0		+8	+12	+20	-2 + Δ		-8 + Δ	-8
24	30																			
30	40	+310	+170	+120	+100	+80	+50	+35	+25	+15	+9	0		+10	+14	+24	-2 + Δ		-9 + Δ	-9
40	50	+320	+180	+130																
50	65	+340	+190	+140	+100	+60	+30	+10	+10	0	0	0		+13	+18	+28	-2 + Δ		-11 + Δ	-11
65	80	+360	+200	+150																
80	100	+380	+220	+170	+120	+72	+36	+12	0	0	0	0		+16	+22	+34	-3 + Δ		-13 + Δ	-13
100	120	+410	+240	+180																
120	140	+460	+260	+200	+145	+85	+43	+14	0	0	0	0		+18	+26	+41	-3 + Δ		-15 + Δ	-15
140	160	+520	+280	+210																
160	180	+580	+310	+230	+170	+100	+50	+15	0	0	0	0		+22	+30	+47	-4 + Δ		-17 + Δ	-17
180	200	+660	+340	+240																
200	225	+740	+380	+260	+190	+110	+56	+17	0	0	0	0		+25	+36	+55	-4 + Δ		-20 + Δ	-20
225	250	+820	+420	+280																
250	280	+920	+480	+300	+210	+125	+62	+18	0	0	0	0		+29	+39	+60	-4 + Δ		-21 + Δ	-21
280	315	+1 050	+540	+330																
315	355	+1 200	+600	+360	+230	+135	+68	+20	0	0	0	0		+33	+43	+66	-5 + Δ		-23 + Δ	-23
355	400	+1 350	+680	+400																
400	450	+1 500	+760	+440	+260	+145	+76	+22	0	0	0	0					0		-26	
450	500	+1 650	+840	+480																
500	560				+290	+160	+80	+24	0	0	0	0					0		-30	
560	630																			
630	710				+320	+170	+86	+26	0	0	0	0					0		-34	
710	800																			
800	900				+350	+195	+98	+28	0	0	0	0					0		-40	
900	1 000																			
1 000	1 120				+390	+220	+110	+30	0	0	0	0					0		-48	
1 120	1 250																			
1 250	1 400				+430	+240	+120	+32	0	0	0	0					0		-58	
1 400	1 600																			
1 600	1 800				+480	+260	+130	+34	0	0	0	0					0		-68	
1 800	2 000																			
2 000	2 240				+520	+290	+145	+38	0	0	0	0					0		-76	
2 240	2 500																			
2 500	2 800																			
2 800	3 150																			

Deviations = ± IT_r/2, where *r* is the standard tolerance grade number

^a Fundamental deviations A and B shall not be used for nominal sizes ≤ 1 mm.

^b Special case: for tolerance class M6 in the range above 250 mm up to and including 315 mm, *ES* = -9 μm (instead of -11 μm according to the calculation).

^c For determining the values K and M, see 4.3.2.5.

^d For Δ values, see Table 3.

Table 3 — Values of the fundamental deviations for holes N to ZC

Fundamental deviation values and Δ values in micrometres

Nominal size mm		Fundamental deviation values Upper limit deviation, <i>E_S</i>														Values for Δ								
Above	Up to and including	Up to and including IT8	Above IT8	Up to and including IT7	Standard tolerance grades above IT7														Standard tolerance grades					
					P	R	S	T	U	V	X	Y	Z	ZA	ZB	ZC	IT3	IT4	IT5	IT6	IT7	IT8		
—	3	-4	-4	P to ZC ^a	-6	-10	-14	-18	-20	-26	-32	-40	-60	0	0	0	0	0	0	0				
3	6	-8 + Δ	0	Values as for standard tolerance grades above IT7 increased by Δ	-12	-15	-19	-23	-28	-35	-42	-50	-80	1	1,5	1	1	1	1	1				
6	10	-10 + Δ	0		-15	-19	-23	-28	-34	-42	-52	-67	-97	1	1,5	2	3	3	3	3				
10	14	-12 + Δ	0		-18	-23	-28	-33	-40	-50	-64	-90	-130	1	2	3	3	3	3	3	3			
14	18				-18	-23	-28	-33	-40	-50	-64	-90	-130	1	2	3	3	3	3	3	3			
18	24	-15 + Δ	0		-22	-28	-35	-41	-47	-54	-63	-73	-88	-188	1,5	2	3	4	4	4	4	12		
24	30				-26	-34	-43	-48	-55	-64	-75	-88	-118	-218	1,5	2	3	4	4	4	4	12		
30	40	-17 + Δ	0		-26	-34	-43	-48	-55	-64	-75	-88	-118	-218	1,5	2	3	4	4	4	4	14		
40	50				-32	-41	-53	-66	-87	-102	-122	-144	-172	-300	2	3	5	6	6	6	6	16		
50	65	-20 + Δ	0		-32	-41	-53	-66	-87	-102	-122	-144	-172	-300	2	3	5	6	6	6	6	16		
65	80				-37	-43	-59	-75	-102	-120	-146	-174	-210	-480	2	4	5	7	7	7	7	19		
80	100	-23 + Δ	0		-37	-43	-59	-75	-102	-120	-146	-174	-210	-480	2	4	5	7	7	7	7	19		
100	120				-43	-43	-59	-75	-102	-120	-146	-174	-210	-480	3	4	6	7	7	7	7	23		
120	140	-27 + Δ	0		-43	-43	-59	-75	-102	-120	-146	-174	-210	-480	3	4	6	7	7	7	7	23		
140	160				-43	-43	-59	-75	-102	-120	-146	-174	-210	-480	3	4	6	7	7	7	7	23		
160	180			-43	-43	-59	-75	-102	-120	-146	-174	-210	-480	3	4	6	7	7	7	7	23			
180	200			-43	-43	-59	-75	-102	-120	-146	-174	-210	-480	3	4	6	7	7	7	7	23			
200	225	-31 + Δ	0	-50	-50	-68	-88	-118	-148	-188	-238	-335	-685	3	4	6	9	9	9	17	26			
225	250			-50	-50	-68	-88	-118	-148	-188	-238	-335	-685	3	4	6	9	9	9	17	26			
250	280			-56	-56	-76	-96	-126	-156	-196	-246	-356	-756	4	4	7	9	9	9	20	29			
280	315	-34 + Δ	0	-56	-56	-76	-96	-126	-156	-196	-246	-356	-756	4	4	7	9	9	9	20	29			
315	355			-62	-62	-84	-106	-138	-170	-212	-264	-384	-864	4	4	7	9	9	9	20	29			
355	400	-37 + Δ	0	-62	-62	-84	-106	-138	-170	-212	-264	-384	-864	4	4	7	9	9	9	20	29			
400	450			-68	-68	-92	-116	-140	-164	-200	-248	-368	-896	4	4	7	9	9	9	20	29			
450	500	-40 + Δ	0	-68	-68	-92	-116	-140	-164	-200	-248	-368	-896	4	4	7	9	9	9	20	29			
500	560			-78	-78	-104	-132	-160	-196	-244	-304	-448	-1120	5	5	7	11	11	11	21	32			
560	630	-44		-78	-78	-104	-132	-160	-196	-244	-304	-448	-1120	5	5	7	11	11	11	21	32			

Table 3 (continued)

Nominal size mm		Fundamental deviation values Upper limit deviation, ES																Values for Δ				
		Up to and including IT8	Above IT8	Up to and including IT7	Standard tolerance grades above IT7												Standard tolerance grades					
Above	Up to and including	N ^{a,b}	P	R	S	T	U	V	X	Y	Z	ZA	ZB	ZC	IT3	IT4	IT5	IT6	IT7	IT8		
630	710	-50	-88	-175	-340	-500	-740															
710	800			-185	-380	-560	-840															
800	900	-56	-100	-210	-430	-620	-940															
900	1 000			-220	-470	-680	-1 050															
1 000	1 120	-66	-120	-250	-520	-780	-1 150															
1 120	1 250			-260	-580	-840	-1 300															
1 250	1 400	-78	-140	-300	-640	-960	-1 450															
1 400	1 600			-330	-720	-1 050	-1 600															
1 600	1 800	-92	-170	-370	-820	-1 200	-1 850															
1 800	2 000			-400	-920	-1 350	-2 000															
2 000	2 240	-110	-195	-440	-1 000	-1 500	-2 300															
2 240	2 500			-460	-1 100	-1 650	-2 500															
2 500	2 800	-135	-240	-550	-1 250	-1 900	-2 900															
2 800	3 150			-580	-1 400	-2 100	-3 200															

a For determining the values N and P to ZC, see 4.3.2.5

b Fundamental deviations N for standard tolerance grades above IT8 shall not be used for nominal sizes ≤ 1 mm.

Table 4 — Values of the fundamental deviations for shafts a to j

Fundamental deviation values in micrometres

Nominal size mm		Fundamental deviation values												Lower deviation, <i>ei</i>			
Above	Up to and including	Upper limit deviation, <i>es</i>												IT5 and IT6	IT7	IT8	
		All standard tolerance grades															
		a ^a	b ^a	c	cd	d	e	ef	f	fg	g	h	js				j
—	3	-270	-140	-60	-34	-20	-14	-10	-6	-4	-2	0			-2	-4	-6
3	6	-270	-140	-70	-46	-30	-20	-14	-10	-6	-4	0			-2	-4	
6	10	-280	-150	-80	-56	-40	-25	-18	-13	-8	-5	0			-2	-5	
10	14	-290	-150	-95	-70	-50	-32	-23	-16	-10	-6	0			-3	-6	
14	18																
18	24	-300	-160	-110	-85	-65	-40	-25	-20	-12	-7	0			-4	-8	
24	30																
30	40	-310	-170	-120	-100	-80	-50	-35	-25	-15	-9	0			-5	-10	
40	50	-320	-180	-130													
50	65	-340	-190	-140	-100	-60	-30			-10	0				-7	-12	
65	80	-360	-200	-150													
80	100	-380	-220	-170	-120	-72				-12	0				-9	-15	
100	120	-410	-240	-180													
120	140	-460	-260	-200	-145	-85				-14	0				-11	-18	
140	160	-520	-280	-210													
160	180	-580	-310	-230	-170	-100				-15	0				-13	-21	
180	200	-660	-340	-240													
200	225	-740	-380	-260	-190	-110				-17	0				-16	-26	
225	250	-820	-420	-280													
250	280	-920	-480	-300	-210	-125				-18	0				-18	-28	
280	315	-1 050	-540	-330													
315	355	-1 200	-600	-360	-230	-135				-20	0				-20	-32	
355	400	-1 350	-680	-400													
400	450	-1 500	-760	-440	-260	-145				-22	0						
450	500	-1 650	-840	-480													
500	560				-290	-160				-24	0						
560	630																
630	710				-320	-170				-26	0						
710	800																
800	900				-350	-195				-28	0						
900	1 000																
1 000	1 120				-390	-220				-30	0						
1 120	1 250																
1 250	1 400				-430	-240				-32	0						
1 400	1 600																
1 600	1 800				-480	-260				-34	0						
1 800	2 000																
2 000	2 240				-520	-290				-38	0						
2 240	2 500																
2 500	2 800																
2 800	3 150																

Deviations = ± IT_n/2, where *n* is the standard tolerance grade number

^a Fundamental deviations a and b shall not be used for nominal sizes ≤ 1 mm.

Table 5 — Values of the fundamental deviations for shafts k to zc

Fundamental deviation values in micrometres

Nominal size mm		Fundamental deviation values Lower limit deviation, <i>e_i</i>																		
Above	Up to and including	IT4 to IT7	Up to and including IT3 and above IT7	All standard tolerance grades																
				k	m	n	p	r	s	t	u	v	x	y	z	za	zb	zc		
—	3	0	0	+2	+4	+6	+10	+14				+18		+20		+26	+32	+40	+60	
3	6	+1	0	+4	+8	+12	+15	+19				+23		+28		+35	+42	+50	+80	
6	10	+1	0	+6	+10	+15	+19	+23				+28		+34		+42	+52	+67	+97	
10	14	+1	0	+7	+12	+18	+23	+28				+33		+40		+50	+64	+90	+130	
14	18																			+39
18	24	+2	0	+8	+15	+22	+28	+35				+41	+47	+54	+63	+73	+98	+136	+188	
24	30																			+41
30	40	+2	0	+9	+17	+26	+34	+43				+48	+60	+68	+80	+94	+112	+148	+200	+274
40	50																			
50	65	+2	0	+11	+20	+32	+41	+53	+66	+87	+102	+122	+144	+172	+226	+300	+405			
65	80																			
80	100	+3	0	+13	+23	+37	+51	+71	+91	+124	+146	+178	+214	+258	+335	+445	+585			
100	120																			
120	140	+3	0	+15	+27	+43	+63	+92	+122	+170	+202	+248	+300	+365	+470	+620	+800			
140	160																			
160	180	+4	0	+17	+31	+50	+77	+122	+166	+236	+284	+350	+425	+520	+670	+880	+1 150			
180	200																			
200	225	+4	0	+20	+34	+56	+84	+140	+196	+284	+340	+425	+520	+640	+820	+1 050	+1 350			
225	250																			
250	280	+4	0	+21	+37	+62	+98	+170	+240	+350	+425	+525	+650	+790	+1 000	+1 300	+1 700			
280	315																			
315	355	+4	0	+23	+40	+68	+114	+208	+294	+435	+530	+660	+820	+1 000	+1 300	+1 650	+2 100			
355	400																			
400	450	+5	0	+26	+44	+78	+132	+252	+360	+540	+660	+820	+1 000	+1 250	+1 600	+2 100	+2 600			
450	500																			
500	560	0	0	+30	+50	+88	+155	+310	+450	+660										
560	630																			
630	710	0	0	+34	+56	+100	+185	+380	+560	+840										
710	800																			
800	900	0	0	+40	+66	+120	+220	+470	+680	+1 050										
900	1 000																			
1 000	1 120	0	0	+48	+78	+140	+260	+580	+840	+1 300										
1 120	1 250																			
1 250	1 400	0	0	+58	+92	+170	+330	+720	+1 050	+1 600										
1 400	1 600																			
1 600	1 800	0	0	+68	+110	+195	+400	+920	+1 350	+2 000										
1 800	2 000																			
2 000	2 240	0	0	+76	+135	+240	+460	+1 100	+1 650	+2 500										
2 240	2 500																			
2 500	2 800	0	0				+580	+1 400	+2 100	+3 200										
2 800	3 150																			

4.4 Selection of tolerance classes

Whenever possible, the tolerance classes should be chosen from those corresponding to the classes for holes and shafts given in Figures 10 and 11, respectively. The first choice should preferably be made from the tolerance classes, shown in the frames.

NOTE 1 The tolerance system of limits and fits gives the possibility of a very wide choice among the various tolerance classes (see Tables 2 to 5), even if this choice is limited only to those shown in ISO 286-2. By restricting the selection of tolerance classes, an unnecessary multiplicity of tools and gauges can be avoided.

NOTE 2 The tolerance classes of Figures 10 and 11 apply only to general purposes which do not require a more specific selection of tolerance classes. Keyways, for example, require a more specific selection.

NOTE 3 Deviations js and JS may be replaced by the corresponding deviations j and J if necessary in a specific application.

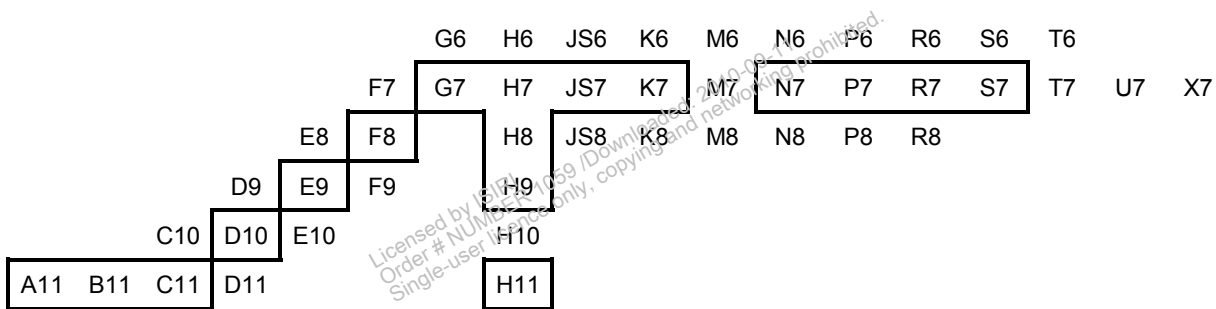

Figure 10 — Holes

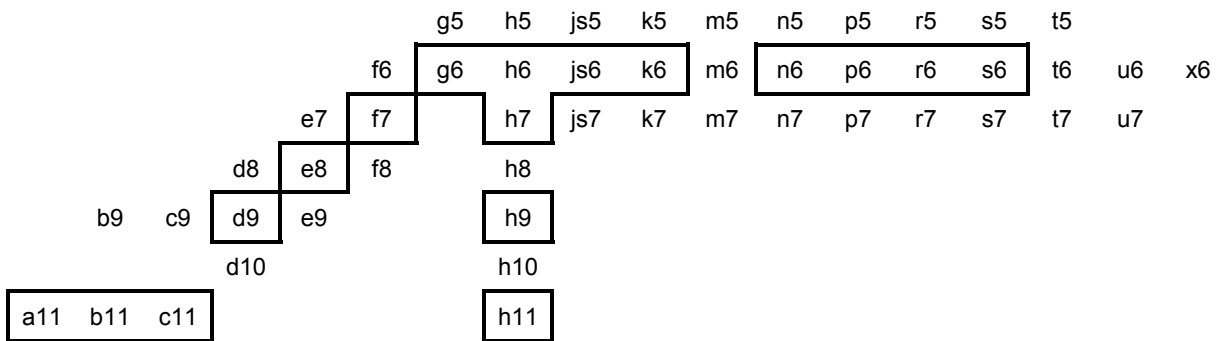

Figure 11 — Shafts

5 ISO fit system

5.1 General

The ISO fit system is based on the “ISO code system for tolerances on linear sizes” for the size of a feature of size. The tolerance classes for the two mating parts in the fit should preferably be chosen in accordance with the advice given in 4.4 and 5.2.

5.2 Generics of fits

5.2.1 Designation of fits (writing rules)

A fit between mating features shall be designated by

- the common nominal size;
- the tolerance class for the hole;
- the tolerance class for the shaft.

EXAMPLE 52 H7/g6 $\text{\textcircled{E}}$ or $52 \frac{\text{H7}}{\text{g6}}$ $\text{\textcircled{E}}$

5.2.2 Determination of the limit deviations (reading rules)

To read the fit designation (e.g. 52H7/g6 $\text{\textcircled{E}}$), apply the rules described in 4.3. To determine the clearances and interferences, see Annex B.

5.3 Determination of a fit

5.3.1 General

There are two possibilities to determine a fit. Determination of a fit either by experience (see 5.3.4) or by calculating the permissible clearances and/or interferences derived from the functional requirements and the production possibilities of the mating parts (see 5.3.5).

5.3.2 Practical recommendations for determining a fit

There are more characteristics than the sizes of the mating parts and their tolerances, which influence the function of a fit. In order to give a complete technical definition of a fit, further influences shall be taken into consideration.

Further influences may be, for example, form, orientation and location deviations, surface texture, density of the material, operating temperatures, heat treatment and material of the mating parts.

Form, orientation and location tolerances may be needed as a supplement to the size tolerances on the mating features of size in order to control the intended function of the fit.

For more information about selecting a fit, see Annex B.

5.3.3 Selection of the fit system

The first decision to be made is whether to adopt the “hole-basis fit system” (hole H) or the “shaft-basis fit system” (shaft h). However, it has to be noted, that there are no technical differences regarding the function of the parts. Therefore the choice of the system should be based on economic reasons.

The “**hole-basis fit system**” should be chosen for general use. This choice would avoid an unnecessary multiplicity of tools (e.g. reamers) and gauges.

The “**shaft-basis fit system**” should only be used where it will convey unquestionable economical advantages (e.g. where it is necessary to be able to mount several parts with holes having different deviations on a single shaft of drawn steel bar without machining the latter).

5.3.4 Determination of a specific fit by experience

Based on the decision taken, the tolerance grades and the fundamental deviation (placement of tolerance interval) should then be chosen for the hole and the shaft to give the corresponding minimum and maximum clearances or interferences that best meet the required conditions of use.

For normal ordinary engineering purposes, only a small number of the many possible fits is required. Figures 12 and 13 indicate those fits which will be found to meet many of the needs of an average engineering organization. For economic reasons, the first choice for a fit should, whenever possible, be made from the tolerance classes shown in the frames (see Figures 12 and 13).

Satisfactory fits are obtained by the following combinations of basic holes system (see Figure 12) or for special applications the combinations of basic shafts system (see Figure 13).

Basic hole	Tolerance classes for shafts															
	Clearance fits				Transition fits				Interference fits							
H 6					g5	h5	js5	k5	m5		n5	p5				
H 7				f6	g6	h6	js6	k6	m6	n6	p6	r6	s6	t6	u6	x6
H 8			e7	f7		h7	js7	k7	m7			s7		u7		
H 9			d8	e8	f8	h8										
H 10	b9	c9	d9	e9		h9										
H 11	b11	c11	d10			h10										

Figure 12 — Preferable fits of the hole-basis system

Basic shaft	Tolerance classes for holes															
	Clearance fits				Transition fits				Interference fits							
h 5					G6	H6	JS6	K6	M6		N6	P6				
h 6				F7	G7	H7	JS7	K7	M7	N7	P7	R7	S7	T7	U7	X7
h 7			E8	F8		H8										
h 8			D9	E9	F9	H9										
h 9				E8	F8		H8									
			D9	E9	F9	H9										
	B11	C10	D10			H10										

Figure 13 — Preferable fits of the shaft-basis system

5.3.5 Determination of a specific fit by calculation

In certain special functional cases, it is necessary to calculate the permissible clearances and/or interferences derived from the functional requirements of the mating parts (see literature). The clearances and/or interferences and the span of the fit obtained from that calculation have to be transformed into limit deviations and if possible into tolerance classes.

For more information about determining tolerance classes, see Annex B.3.

Annex A (informative)

Further information about the ISO system of limits and fits and former practice

A.1 Former practice of default definition of linear size

In ISO 286-1:1988, the default definition of diameters toleranced with ISO-tolerance classes (e.g. $\varnothing 30 H6$) was the Taylor principle (mating size at maximum material limit and local diameter at least material limit) as stated in ISO/R 1938:1971.

That meant that for any features of size toleranced with ISO-tolerance classes the envelope requirement was valid without indicating the latter, even if the toleranced feature of size was not part of a fit.

EXAMPLE $\varnothing 24 h13$ for head diameters of round head screws according to ISO 4759-1, the envelope requirement was valid automatically.

A.2 Detailed interpretation of a toleranced size

The interpretation of a toleranced size according to ISO 286-1:1988 and ISO/R 1938:1971 was made in the following ways within the stipulated length.

a) for holes

The diameter of the largest perfect imaginary cylinder, which can be inscribed within the hole so that it just contacts the highest points of the surface, should not be smaller than the maximum material limit of size.

The maximum local diameter at any position in the hole shall not exceed the least material limit of size.

b) for shafts

The diameter of the smallest perfect imaginary cylinder, which can be circumscribed about the shaft so that it just contacts the highest points of the surface, should not be larger than the maximum material limit of size.

The minimum local diameter at any position on the shaft shall not be less than the least material limit of size.

These interpretations mean that if a feature of size is everywhere at its maximum material limit, that feature should be perfectly round and straight, i.e. a perfect cylinder.

This interpretation is in future only valid when the envelope requirement according to ISO 14405-1 (symbol \textcircled{E}) is indicated on the drawing in addition to the size and the tolerance.

A.3 Change of default definition of linear size

The default definition for a toleranced linear size is changed according to ISO 14405-1 to local size between two opposite points. For the local size of an extracted feature, see ISO 14660-2:1999, 4.2.

To state exactly the same requirement (Taylor principle according to ISO/R 1938:1971) on the drawing, the tolerance statement shall according to ISO 14405-1 be followed by the modifier for mating size, e.g. the envelope requirement.

EXAMPLE $\varnothing 30 \text{ H6 } \textcircled{\text{E}}$

Licensed by ISIRI
Order # NUMBER 1059 / Downloaded: 2010-09-11
Single-user licence only, copying and networking prohibited.

Annex B (informative)

Examples of the use of ISO 286-1 to determine fits and tolerance classes

B.1 General

This annex gives examples in the use of the ISO system of limits and fits in determining the clearances and/or interferences of fits. Furthermore, it contains examples for determining tolerance classes out of fits.

B.2 Determination of fits from the limit deviations

From the definitions of the clearances and the interferences, the calculation of the minimum clearances and the maximum interferences is made using the same formula:

lower limit of size of the hole – upper limit of size of the shaft.

and for the calculation of the maximum clearances and the minimum interferences:

upper limit of size of the hole – lower limit of size of the shaft.

The result of the calculation is a positive or a negative value. From the definitions follows that clearances are positive and interferences are negative. That means a “+ sign” for clearances and a “– sign” for interferences.

After interpreting the results of the calculation the absolute values are taken to communicate and describe the clearances and interferences.

EXAMPLE 1 Calculation of the fit: $\varnothing 36$ H8/f7

From the tables of ISO 286-2 for the hole 36 H8 results:

$ES = +0,039$ mm hence it follows: upper limit of size = 36,039 mm

$EI = 0$ lower limit of size = 36,000 mm

and for the shaft 36 f7 results:

$es = -0,025$ mm hence it follows: upper limit of size = 35,975 mm

$ei = -0,050$ mm lower limit of size = 35,950 mm

Therefore:

lower limit of size of the hole – upper limit of size of the shaft = $36,000 - 35,975 = 0,025$ mm

upper limit of size of the hole – lower limit of size of the shaft = $36,039 - 35,950 = 0,089$ mm

The calculation results in two positive values. That means the fit has a maximum clearance of 0,089 mm and a minimum clearance of 0,025 mm and it is a **clearance fit**.

ISO 286-1:2010(E)

EXAMPLE 2 Calculation of the fit: $\varnothing 36$ H7/n6

From the tables of ISO 286-2 for the hole 36 H7 results:

$ES = +0,025$ mm hence it follows: upper limit of size = 36,025 mm

$EI = 0$ lower limit of size = 36,000 mm

and for the shaft 36 n6 results:

$es = +0,033$ mm hence it follows: upper limit of size = 36,033 mm

$ei = +0,017$ mm lower limit of size = 36,017 mm

Therefore:

lower limit of size of the hole – upper limit of size of the shaft = 36,000 – 36,033 = –0,033 mm

upper limit of size of the hole – lower limit of size of the shaft = 36,025 – 36,017 = +0,008 mm

The calculation results in a positive and a negative value. That means the fit has a clearance of 0,008 mm and an interference of 0,033 mm and is a **transition fit**.

EXAMPLE 3 Calculation of the fit: $\varnothing 36$ H7/s6

From the tables of ISO 286-2 for the hole 36 H7 results:

$ES = +0,025$ mm hence it follows: upper limit of size = 36,025 mm

$EI = 0$ lower limit of size = 36,000 mm

and for the shaft 36 s6 results:

$es = +0,059$ mm hence it follows: upper limit of size = 36,059 mm

$ei = +0,043$ mm lower limit of size = 36,043 mm

Therefore:

lower limit of size of the hole – upper limit of size of the shaft = 36,000 – 36,059 = –0,059 mm

upper limit of size of the hole – lower limit of size of the shaft = 36,025 – 36,043 = –0,018 mm

The calculation results in two negative values. That means the fit has a maximum interference of 0,059 mm and a minimum interference of 0,018 mm and is an **interference fit**.

B.3 Determination of the span of a fit

To determine the span of a fit, use the interpreted results of the calculation.

The span of the clearance fit is by definition: maximum clearances – minimum clearances
 $0,089$ mm – $0,025$ mm = $0,064$ mm (see Figure B.1).

The span of the transition fit is by definition: maximum clearance + maximum interferences
 $0,008$ mm + $0,033$ mm = $0,041$ mm (see Figure B.1).

The span of the interference fit is by definition: maximum interferences – minimum interferences
 $0,059$ mm – $0,018$ mm = $0,041$ mm (see Figure B.1).

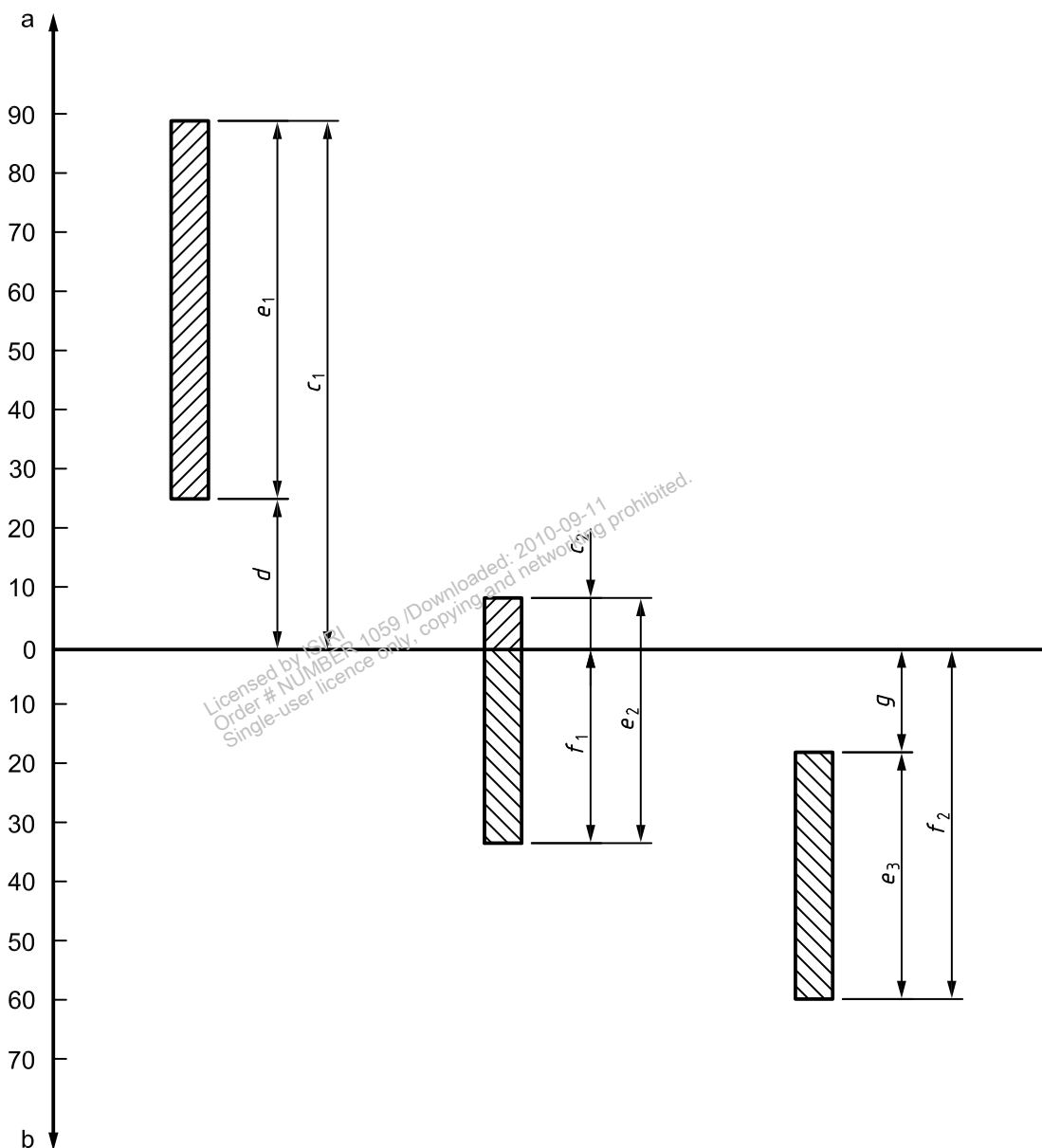

Key

maximum clearance	$c_1 = 0,089 \text{ mm}$	$c_2 = 0,008 \text{ mm}$
minimum clearance	$d = 0,025 \text{ mm}$	
span of a clearance fit	$e_1 = 0,064 \text{ mm}$	
span of a transition fit	$e_2 = 0,041 \text{ mm}$	
span of an interference fit	$e_3 = 0,041 \text{ mm}$	
maximum interference	$f_1 = 0,033 \text{ mm}$	$f_2 = 0,059 \text{ mm}$
minimum interference	$g = 0,018 \text{ mm}$	

- a Clearances.
- b Interferences.

Figure B.1 — Span of fits

B.4 Determination of a specific tolerance class from calculated fits

B.4.1 Magnitude of the tolerance

For the transformation of a calculated fit into limit deviations, and if possible into tolerance classes, first the magnitudes of the tolerances have to be determined by using Table 1 of this part of ISO 286 according to the following formula:

Span of the calculated fit \geq IT-value for the hole + IT-value for the shaft

EXAMPLE	Calculated fit:	Nominal size	40 mm
	(see 5.3.5)	Minimum clearance	24 μ m
		Maximum clearance	92 μ m
		Span of the clearance fit	68 μ m

The sum of two selected standard tolerance values has to be equal or smaller than the span of the calculated fit.

Half of the span of the fit is 34 μ m. In Table 1, in the line of the nominal size range above 30 up to and including 50 mm, the value 34 μ m is situated between 25 μ m and 39 μ m. The sum of the table values is 64 μ m which is smaller than 68 μ m.

Hence, it follows: One standard tolerance is 25 μ m and the standard tolerance grade is IT7.

The second standard tolerance is 39 μ m and the standard tolerance grade is IT8.

B.4.2 Determination of the deviations and the tolerance class

Then the decision has to be made whether to adopt the hole-basis fit system (hole H) or the shaft-basis fit system (shaft h) or another combination of fundamental deviations, see 5.3.3.

For the example below, the hole-basis fit system has been chosen according to 5.3.3. Therefore, the tolerance class identifier is H and Table 2 applies for the determination of the tolerance class.

EXAMPLE	Nominal size (from Example B.4.1) 40 mm
	Chosen fit system hole H

a) Determination of the tolerance class for the hole

Chosen standard tolerance grade for the hole (from Example B.4.1): IT8

In Table 2, the fundamental deviation can be chosen in the column H

the lower limit deviation $EI = 0$

the upper limit deviation follows from $ES = EI + IT = 0 + 39$ (IT8) = + 39 μ m

Hence, it follows: lower limit of size of the hole is 40 mm
 upper limit of size of the hole is 40,039 mm
 tolerance class for the hole is H8 and the size of the feature is 40 H8.

b) Determination of the tolerance class for the shaft

From the definition of the minimum clearance (see 3.3.1.1), it follows:

minimum clearances = lower limit of size of the hole – upper limit of size of the shaft

Calculated minimum clearance (from Example B.4.1) 24 μ m = 0,024 mm

lower limit of size of the hole 40 mm

Hence, it follows:

0,024 mm = 40 mm – upper limit of size of the shaft

and

upper limit of size of the shaft = 40 mm – 0,024 mm = 39,976 mm

From the definition of the upper limit deviation (see 3.2.5.1), it follows:

$$es = \text{upper limit of size} - \text{nominal size}$$

$$es = 39,976 - 40 = -0,024 \text{ mm} = -24 \text{ }\mu\text{m}$$

In Table 4, in the line of the nominal size range above 30 mm up to and including 50 mm, the value $-25 \text{ }\mu\text{m}$ can be found for es .

Hence, it follows: for $es = -25 \text{ }\mu\text{m}$ the tolerance class identifier is "f", and

$$\text{lower deviation } ei = es - IT7 = -25 - 25 = -50 \text{ }\mu\text{m}$$

and tolerance class for the shaft is f7 and the size of the feature is 40 f7.

c) Control of the fit

The designation of the fit is 40 H8/f7.

From the calculation similar to B.2, Example 1 follows:

minimum clearance $25 \text{ }\mu\text{m}$

maximum clearance $89 \text{ }\mu\text{m}$

From the functional requirement was calculated:

actual calculated minimum clearance $24 \text{ }\mu\text{m}$

actual calculated maximum clearance $92 \text{ }\mu\text{m}$

The person who is responsible for the function of the mating parts has to decide if the deviations from the original calculated fit can be tolerated or if the exact minimum and maximum clearances have to be observed.

In any case, for the part with the hole, the toleranced dimension "40 H8" will be chosen. For the part with the shaft, the size 40, the tolerance class "f7 ($-0,025/-0,050$)" or the individual deviations " $-0,024/-0,053$ " will be chosen.

Annex C (informative)

Relationship to the GPS matrix model

C.1 General

For full details about the GPS matrix model, see ISO/TR 14638.

C.2 Information about this International Standard and its use

This part of ISO 286 establishes a code-system for tolerances to be used for sizes of nominal integral features of size. It also defines the basic concepts and the related terminology for this code system. Furthermore it defines the basic terminology for fits and explains the principles of “basic hole” and “basic shaft”.

C.3 Position in the GPS matrix model

This part of ISO 286 is a GPS standard and is to be regarded as a general GPS standard (see ISO/TR 14638). It influences chain links 1 and 2 of the chains of standards on size in the general GPS matrix, as graphically illustrated in Figure C.1.

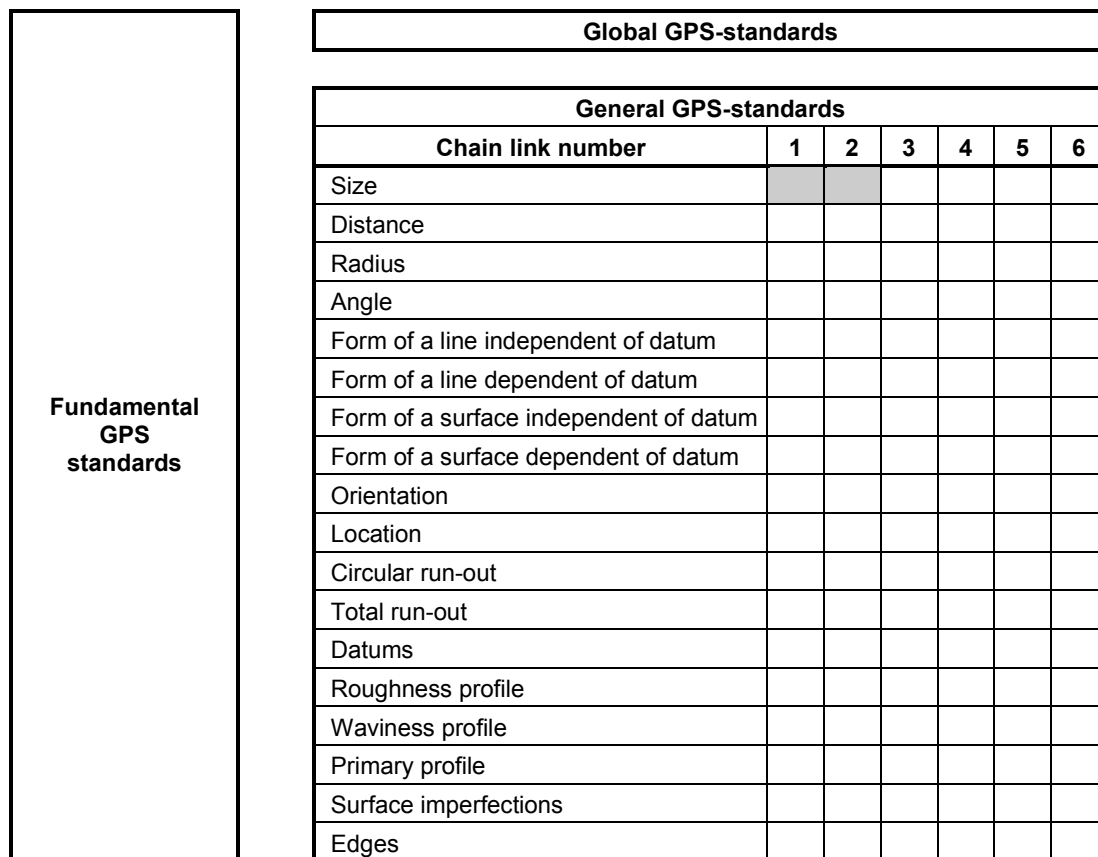

Figure C.1 — Position in the GPS matrix model

C.4 Related International Standards

The related International Standards are those of the chains of standards indicated in Figure C.1.

Licensed by ISIRI
Order # NUMBER 1059 /Downloaded: 2010-09-11
Single-user licence only, copying and networking prohibited.

Bibliography

- [1] ISO 1:2002, *Geometrical Product Specifications (GPS) — Standard reference temperature for geometrical product specification and verification*
- [2] ISO 1101:2004, *Geometrical Product Specifications (GPS) — Geometrical tolerancing — Tolerances of form, orientation, location and run-out*
- [3] ISO 1302:2002, *Geometrical Product Specifications (GPS) — Indication of surface texture in technical product documentation*
- [4] ISO/R 1938:1971, *ISO system of limits and fits — Part II : Inspection of plain workpieces*
- [5] ISO 2692:2006, *Geometrical product specifications (GPS) — Geometrical tolerancing — Maximum material requirement (MMR), least material requirement (LMR) and reciprocity requirement (RPR)*
- [6] ISO 2768-1:1989, *General tolerances — Part 1: Tolerances for linear and angular dimensions without individual tolerance indications*
- [7] ISO 3534-1:2006, *Statistics — Vocabulary and symbols — Part 1: General statistical terms and terms used in probability*
- [8] ISO 3534-2:2006, *Statistics — Vocabulary and symbols — Part 2: Applied statistics*
- [9] ISO 4759-1, *Tolerances for fasteners — Part 1: Bolts, screws, studs and nuts — Product grades A, B and C*
- [10] ISO 14253-1:1998, *Geometrical Product Specifications (GPS) — Inspection by measurement of workpieces and measuring equipment — Part 1: Decision rules for proving conformance or non-conformance with specifications*
- [11] ISO/TR 14638:1995, *Geometrical product specifications (GPS) — Masterplan*
- [12] ISO 17450-1:—², *Geometrical product specifications (GPS) — General concepts — Part 1: Model for geometrical specification and verification*
- [13] ISO/TS 17450-2:2002, *Geometrical product specifications (GPS) — General concepts — Part 2: Basic tenets, specifications, operators and uncertainties*

2) To be published. (Revision of ISO/TS 17450-1:2005)

Licensed by ISIRI
Order # NUMBER 1059 /Downloaded: 2010-09-11
Single-user licence only, copying and networking prohibited.